

# **Mobile DVR User's Manual**

**V 1.0.0**

# Table of Contents

|       |  |    |
|-------|--|----|
| 1     | Features and Specifications .....                    | 1  |
| 1.1   | Overview.....  | 1  |
| 1.2   | Function.....  | 1  |
| 1.3   | Features.....  | 3  |
| 1.4   | Specifications.....                                  | 3  |
| 2     | Front Panel and Rear Panel.....                      | 8  |
| 2.1   | Front Panel.....                                     | 8  |
| 2.2   | Rear Panel .....                                     | 9  |
| 2.3   | Remote Control .....                                 | 12 |
| 2.4   | Mouse Operation.....                                 | 13 |
| 3     | Installation and Connections .....                   | 15 |
| 3.1   | Check Unpacked DVR.....                              | 15 |
| 3.2   | HDD Installation.....                                | 15 |
| 3.3   | Connecting Power Supply.....                         | 17 |
| 3.4   | Connecting Audio/Video Input and Output Devices..... | 17 |
| 3.4.1 | Connecting Video Input .....                         | 17 |
| 3.4.2 | Audio Input .....                                    | 18 |
| 3.4.3 | Connecting Video Output .....                        | 19 |
| 3.4.4 | Audio Output .....                                   | 19 |
| 3.5   | Alarm Input and Output Connection .....              | 21 |
| 3.5.1 | Alarm Input and Output Details .....                 | 21 |
| 3.5.2 | Alarm Input Port.....                                | 22 |
| 3.5.3 | Alarm Output Port.....                               | 23 |
| 4     | GUI Operation.....                                   | 25 |
| 4.1   | Login.....   | 25 |

|          |                        |    |
|----------|------------------------|----|
| 4.2      | Navigation Bar .....   | 27 |
| 4.3      | Right Click Menu ..... | 27 |
| 4.4      | Main Menu.....         | 28 |
| 4.5      | Search & Playback..... | 28 |
| 4.5.1    | Mark Playback .....    | 32 |
| 4.6      | Information .....      | 33 |
| 4.6.1    | HDD Information .....  | 34 |
| 4.6.2    | BPS.....               | 35 |
| 4.6.3    | Log.....               | 36 |
| 4.6.4    | Version .....          | 37 |
| 4.6.5    | Online Users.....      | 38 |
| 4.6.6    | Network Info .....     | 38 |
| 4.6.6.1  | Network Test.....      | 38 |
| 4.6.6.2  | Network Load .....     | 39 |
| 4.7      | Setting.....           | 40 |
| 4.7.1    | General .....          | 40 |
| 4.7.2    | Encode .....           | 43 |
| 4.7.3    | Schedule.....          | 45 |
| 4.7.4    | RS232 .....            | 46 |
| 4.7.5    | Network.....           | 47 |
| 4.7.5.1  | Network Setting .....  | 48 |
| 4.7.5.2  | NTP Setup.....         | 48 |
| 4.7.5.3  | DDNS .....             | 49 |
| 4.7.5.4  | UPNP .....             | 51 |
| 4.7.5.5  | 3G Setting.....        | 52 |
| 4.7.5.6  | WIFI.....              | 53 |
| 4.7.5.7  | Email .....            | 55 |
| 4.7.5.8  | FTP.....               | 56 |
| 4.7.5.9  | Alarm center .....     | 58 |
| 4.7.5.10 | Auto register .....    | 58 |
| 4.7.6    | Alarm .....            | 59 |
| 4.7.7    | Detect .....           | 62 |
| 4.7.7.1  | Motion Detect.....     | 62 |
| 4.7.7.2  | Video Loss.....        | 65 |
| 4.7.7.3  | Camera Masking .....   | 66 |
| 4.7.8    | PTZ.....               | 66 |
| 4.7.9    | Display .....          | 71 |
| 4.7.10   | Default.....           | 73 |
| 4.8      | Advanced.....          | 74 |

|         |                                   |    |
|---------|-----------------------------------|----|
| 4.8.1   | HDD Management.....               | 74 |
| 4.8.2   | Abnormality.....                  | 75 |
| 4.8.3   | Alarm Output.....                 | 76 |
| 4.8.4   | Manual Record.....                | 76 |
| 4.8.4.1 | Manual record menu.....           | 77 |
| 4.8.4.2 | Basic operation.....              | 77 |
| 4.8.4.3 | Enable/disable record.....        | 77 |
| 4.8.4.4 | Enable all channel recording..... | 78 |
| 4.8.4.5 | Stop all channel recording.....   | 78 |
| 4.8.5   | Account.....                      | 79 |
| 4.8.5.1 | Modify Password.....              | 80 |
| 4.8.5.2 | Add/Modify Group.....             | 80 |
| 4.8.5.3 | Add/Modify User.....              | 81 |
| 4.8.6   | Auto Maintenance.....             | 81 |
| 4.8.7   | TV Adjust.....                    | 82 |
| 4.8.8   | Config Backup.....                | 82 |
| 4.8.9   | Vehicle Setting.....              | 83 |
| 4.9     | Backup.....                       | 84 |
| 4.9.1   | Detect Device.....                | 84 |
| 4.9.2   | Backup.....                       | 85 |
| 4.9.3   | One key backup.....               | 86 |
| 4.10    | Shutdown.....                     | 86 |
| 5       | WEB OPERATION.....                | 88 |
| 5.1     | Network Connection.....           | 88 |
| 5.2     | Login.....                        | 88 |
| 5.3     | LAN Mode.....                     | 90 |
| 5.4     | Real-time Monitor.....            | 92 |
| 5.5     | PTZ.....                          | 92 |
| 5.6     | Image/Relay-out.....              | 93 |
| 5.6.1   | Image.....                        | 93 |
| 5.6.2   | Relay output.....                 | 94 |
| 5.6.3   | Multiple-channel preview.....     | 94 |
| 5.7     | WAN Login.....                    | 94 |
| 5.8     | Setup.....                        | 95 |
| 5.8.1   | Channel.....                      | 95 |

|           |                        |     |
|-----------|------------------------|-----|
| 5.8.1.1   | Conditions.....        | 95  |
| 5.8.1.2   | Video and Audio.....   | 97  |
| 5.8.1.2.1 | Encode .....           | 97  |
| 5.8.1.2.2 | Snapshot.....          | 98  |
| 5.8.1.2.3 | Video Overlay .....    | 99  |
| 5.8.1.2.4 | Multiple-Preview ..... | 99  |
| 5.8.1.2.5 | Preview Overlay.....   | 100 |
| 5.8.1.2.6 | Path .....             | 100 |
| 5.8.1.3   | Channel Name.....      | 101 |
| 5.8.2     | Network.....           | 101 |
| 5.8.2.1   | TCP/IP.....            | 101 |
| 5.8.2.2   | Connection .....       | 102 |
| 5.8.2.3   | WIFI.....              | 103 |
| 5.8.2.4   | 3G .....               | 103 |
| 5.8.2.4.1 | CDMA/GPRS .....        | 103 |
| 5.8.2.4.2 | Mobile.....            | 104 |
| 5.8.2.5   | DDNS .....             | 105 |
| 5.8.2.6   | Email .....            | 106 |
| 5.8.2.7   | UPnP.....              | 108 |
| 5.8.2.8   | Auto Register .....    | 108 |
| 5.8.2.9   | Alarm Centre.....      | 109 |
| 5.8.3     | Event.....             | 109 |
| 5.8.3.1   | Video detect.....      | 109 |
| 5.8.3.1.1 | Motion Detect .....    | 109 |
| 5.8.3.1.2 | Video Loss .....       | 112 |
| 5.8.3.1.3 | Camera Masking .....   | 112 |
| 5.8.3.2   | Alarm.....             | 113 |
| 5.8.3.2.1 | Local Alarm .....      | 113 |
| 5.8.3.2.2 | Net Alarm.....         | 115 |
| 5.8.3.2.3 | Alarm Out .....        | 115 |
| 5.8.3.3   | Abnormality.....       | 116 |
| 5.8.4     | Storage.....           | 117 |
| 5.8.4.1   | Schedule .....         | 117 |
| 5.8.4.2   | Storage.....           | 119 |
| 5.8.4.2.1 | Local Storage .....    | 119 |
| 5.8.4.2.2 | FTP.....               | 119 |
| 5.8.4.3   | Record control .....   | 120 |
| 5.8.5     | System .....           | 121 |
| 5.8.5.1   | General .....          | 121 |
| 5.8.5.1.1 | General.....           | 121 |
| 5.8.5.1.2 | Date and time .....    | 121 |
| 5.8.5.1.3 | Holiday Setup.....     | 122 |
| 5.8.5.2   | Account .....          | 123 |
| 5.8.5.2.1 | User name .....        | 123 |
| 5.8.5.2.2 | Group .....            | 125 |
| 5.8.5.3   | Display.....           | 126 |

|           |  |     |
|-----------|--|-----|
| 5.8.5.3.1 | GUI .....  | 126 |
| 5.8.5.3.2 | TV Adjust.....   | 127 |
| 5.8.5.3.3 | Tour.....  | 127 |
| 5.8.5.4   | Default.....   | 128 |
| 5.8.5.5   | Import/Export.....                                       | 128 |
| 5.8.5.6   | Auto Maintenance .....                                   | 129 |
| 5.8.5.7   | Upgrade .....  | 129 |
| 5.8.5.8   | RS232 .....  | 130 |
| 5.8.5.9   | PTZ.....   | 130 |
| 5.8.6     | Information.....   | 131 |
| 5.8.6.1   | Version .....  | 131 |
| 5.8.6.2   | Log.....   | 132 |
| 5.8.7     | Vehicle.....   | 132 |
| 5.9       | Search.....  | 133 |
| 5.10      | Alarm.....   | 137 |
| 5.11      | Log out.....   | 137 |
| 5.12      | Un-install Web Control.....                              | 138 |
| 6         | Digital Surveillance System .....                        | 139 |
| 7         | FAQ .....  | 140 |
| 8         | Appendix A HDD Capacity Calculation.....                 | 145 |
| 9         | Appendix B Compatible SATA HDD .....                     | 146 |
|           | Appendix C Glossary .....                                | 147 |
|           | Appendix D Toxic or Hazardous Materials or Elements..... | 148 |

## **Welcome**

Thank you for purchasing our digital video recorder!

This user's manual is designed to be a reference tool for your system.

Please open the accessory bag to check the items one by one in accordance with the list below.

Contact your local retailer ASAP if something is missing or damaged in the bag.

# Important Safeguards and Warnings

## 1 . Electrical safety

All installation and operation here should conform to your local electrical safety codes. We assume no liability or responsibility for all the fires or electrical shock caused by improper handling or installation.

## 2 . Transportation security

Heavy stress, violent vibration or water splash are not allowed during transportation, storage and installation.

## 3 . Installation

Keep upwards. Handle with care.

Do not apply power to the DVR before completing installation.

Do not place objects on the DVR

## 4 . Qualified engineers needed

All the examination and repair work should be done by the qualified service engineers.

We are not liable for any problems caused by unauthorized modifications or attempted repair.

## 5 . Environment

The DVR should be installed in a cool, dry place away from direct sunlight, inflammable, explosive substances and etc.

This series product shall be transported, storage and used in the specified environments.

## 6. Accessories

Be sure to use all the accessories recommended by manufacturer.

Before installation, please open the package and check all the components are included.

Contact your local retailer ASAP if something is broken in your package.

## 7. Lithium battery

Improper battery use may result in fire, explosion, or personal injury!

When replace the battery, please make sure you are using the same model!

**Before your operation please read the following instructions carefully.**

- **Installation environment**

- ✧ Keep away from extreme hot places and sources;
- ✧ Avoid direct sunlight;
- ✧ Keep away from extreme humid places;
- ✧ Avoid violent vibration;
- ✧ Do not put other devices on the top of the DVR;
- ✧ Be installed in well ventilated place; do not block the vent.

- **Accessories**

Check the following accessories after opening the box:

- **Please refer to the packing list in the box \***

# 1 Features and Specifications

## 1.1 Overview

This series mobile DVR is a high-end HD digital video surveillance management product.

- This series product integrates image process technology, wireless network technology, GPS technology, structure technology and vehicle information sampling and process technology together.
- It adopts strong aluminum alloy case and adopts one 2.5-inch HDDs as the storage media. It supports built-in 3G, WIFI wireless transmission mode and GPS module (optional) .
- Installed on the vehicle, it can realize local audio/video storage and vehicle information sampling, at the same time it can transmit real-time video and vehicle information to the remote management centre and establish real-time remote wireless surveillance management system.

This series DVR can be widely used in many vehicle area or mobile surveillance area such as long-distance passenger transport, city public transportation, public security system, road administration, logistics vehicle.

## 1.2 Function

**Slight difference may be found due to different series products.**

It has analog output port and VGA port. You can use monitor or displayer to realize surveillance function.

System supports TV/VGA output at the same time.

- **Storage function**

Special data format to guarantee data security and can avoid vicious data modification.

- **Compression format**

Support multiple-channel audio and video signal. An independent hardware decodes the audio and video signal from each channel to maintain video and audio synchronization.

- **Backup function**

Support backup operation via USB port (such as flash disk, portable HDD)

Client-end user can download the DVR file to local HDD to backup via network.

- **Record playback function**

Support each channel real-time record independently, and at the same time it can support search, forward play, network monitor, record search, download and etc.

Support various playback modes: slow play, fast play, backward play and frame by frame play.

Support time title overlay so that you can view event accurate occurred time

Support specified zone enlargement.

- **Network operation**

Support network remote real-time monitor, remote record search and remote PTZ control.

- **Alarm activation function**

Several relay alarm outputs to realize alarm activation and on-site light control.

The alarm input port and output port has the protection circuit to guarantee device safety.

- **Communication port**

RS485 port can realize alarm input and PTZ control.

RS232 port can connect to keyboard to realize central control, and can also connect to PC COM to upgrade system and realize maintenance.

Standard Ethernet port can realize network access function.

- **PTZ control**

Support PTZ decoder via RS485.

Support various decode protocols to allow the PTZ to control the speed dome.

- **Intelligent operation**

Mouse operation function

In the menu, support copy and paste setup function

- **GPS positioning**

The GSP information can activate the record function while the search function can activate the vehicle movement track.

**Please note only the unit of GPS module supports this function.**

- **3G network**

Latest wireless network communication technology allows you to easily control the device.

**Please note only the unit of 3G module supports this function.**

- **Drawn-out HDD design**

The professional drawn-out anti-vibration design. It supports fix and removable operation and can connect to PC to realize fast and convenience data backup.

- **Dual-backup**

Save record file on the SD card to enhance safety and operation feasibility.

- **One-button operation**

You can click just one button to realize record backup, program upgrade, which makes it suitable for the daily maintenance and operation in the vehicle.

- **Dual-stream**

Considering the wireless network band is small and the network is not stable, system adopts the dual stream to implement real-time record and network transmission independently, which greatly optimizes the network transmission encode code and enhance the wireless network control compatibility.

- **Vehicle status record**

There are seven external alarm ports. You can connect to the door signal, direction indicator lamp signal, reversing light signal, stop lamp signal and etc to prompt the driver and record vehicle status.

### 1.3 Features

- Adopt dual-HDD as storage media to enhance record save period.
- Aluminum alloy case, small and sound ventilation, high stability.
- Abundant functions, support various alarm mode, record mode and support multiple information, vehicle status sampling and record function.
- Built-in 3G, WIFI wireless transmission module, and GPS module.
- Support TV/VGA dual-output.

### 1.4 Specifications

|                      | Parameter         | 4-ch   |
|----------------------|-------------------|--|
| System               | Main Processor    | High-performance industrial embedded micro controller  |
|                      | OS                | Embedded LINUX   |
|                      | System Resources  | Multiplex operations: Multiple-channel record, multiple-channel playback and network operation simultaneously  |
|                      | Interface         | User-friendly graphical user interface   |
|                      | Input Devices     | Mouse, remote control  |
|                      | Input Method      | Arabic number, English character, donation and extension Chinese (optional)  |
|                      | Shortcut Function | Copy/paste operation, USB mouse right-key shortcut menu, double click USB mouse to switch screen.  |
| Compression Standard | Video Compression | H.264  |
|                      | Audio Compression | G711A, G711U , PCM   |
| Video monitor        | Video Input       | 4-CH composite video input: (NTSC/PAL) BNC (1.0V <sub>P-P</sub> , 75Ω)   |
|                      | Video Output      | 1-ch PAL/NTSC, aviation port (1.0V <sub>P-P</sub> , 75Ω) composite video signal output.<br>1-ch VGA output.<br>Support TV/VGA video output at the same time. |
|                      | Video Standard    | Support PAL/NTSC.  |
|                      | Record Speed      | Real-time Mode: PAL 1f/s to 25f/s per channel and NTSC 1f/s to 30f/s per channel   |
|                      | Video Partition   | 1/4 windows  |

|                     |  |  |
|---------------------|--|--|
|                     | Monitor Touring  | Support monitor tour functions such as alarm, motion detection, and schedule auto control.   |
|                     | Resolution (PAL/NTSC)  | PAL/NTSC<br>Real-time monitor:<br>D1 704×576/704×480   |
|                     |  | Playback:<br>1/4-ch: D1 704×576/704×480, HD1 352×576/352×480, 2CIF 704×288/704×240, CIF 352×288/ 352×240 , QCIF 176×144/176×120  |
|                     |  | Support dual streams: extra stream resolution CIF 352×288/ 352×240, QCIF 176×144/176×120.  |
|                     | Image Quality  | 6-level image quality (Adjustable)   |
|                     | Privacy mask   | Support one privacy mask of user-defined size in full screen.<br>Support max 4 zones.  |
|                     | Image Information  | Channel information, time information and privacy mask zone.   |
|                     | TV Adjust  | Adjust TV output zone suitable to anamorphic video.  |
|                     | Channel Lock   | Cover secret channel with black screen though system is encoding normally.<br>Screen-lock function to prevent unauthorized user seeing secret video.                               |
|                     | Channel Information  | Channel name, recording status, screen lock status, video loss status and motion detection status are shown on the bottom left of display screen.                                  |
| Color Configuration | Hue, brightness, contrast, saturation and gain setup for each channel. |  |
| Audio               | Audio Input  | 4-ch aviation port audio input. 200-2000mv 10KΩ.   |
|                     | Audio Output   | 1-ch aviation port audio output. 200-3000mv 5KΩ (BNC).   |
|                     | Bidirectional Audio  | Support bidirectional talk function. Support special mobile microphone input.  |
| Hard disk           | Hard Disk  | 1 built-in SATA port. Support 1 HDD.   |
|                     | Hard Disk Occupation   | Audio: PCM 28.8MByte/h<br>Video: 56-900MByte/h   |
| Record and playback | Recording Mode   | Manual recording, motion detection recording, schedule recording and alarm recording<br>Priority: Manual recording> alarm recording>motion detection recording>schedule recording. |
|                     | Recording Length   | 1 to 120 minutes single record duration (Default setup is 60 minutes)  |
|                     | Playback Repeat Way  | When hard disk is full, system can overwrite previous video file.  |
|                     | Record Search  | Various search engines such as time, type and channel.   |

|                            |                          |  |
|----------------------------|--------------------------|--|
|                            | Playback Mode            | Various fast play, slow play speeds, manual frame by frame playback and reverse play mode.   |
|                            | Various File Switch Ways | Can switch to previous or next file or any file in current play list.<br>Can switch to file on other channel of the same time. (If there is a file)<br>Support file continuous play, when a file is end system auto plays the next file in the current channel |
|                            | Multi-channel Playback   | There is 1/4channel playback mode.   |
|                            | Window Zoom              | Switch between self-adaptive screen/full screen when playback  |
|                            | Partial Enlargement      | When in one-window full-screen playback mode, you can select any zone to activate partial enlargement function.  |
| Backup function            | Backup Mode              | HDD backup   |
|                            |                          | Support peripheral USB backup device. (Flash drive)  |
|                            |                          | Support network download and save  |
| Network Function           | Network control          | View monitor channel remotely.   |
|                            |                          | DVR configuration through client-end and web browser   |
|                            |                          | Upgrade via client or browser to realize remote maintenance.   |
|                            |                          | View alarm information such as external alarm, motion detection and video loss via client.   |
|                            |                          | File download backup and playback  |
|                            |                          | Multiple devices share information via corresponding software such as professional surveillance software (PSS)   |
|                            |                          | Duplex transparent COM   |
|                            |                          | Network alarm input and output   |
|                            |                          | Bidirectional audio.   |
| Motion Detection and Alarm | Motion Detection         | Zone setup: support 396((PAL 22×18, NTSC 22×15)) detection zones.<br>Various sensitivity levels.<br>Alarm can activate record or external alarm or screen message prompt.  |
|                            | Video Loss               | Alarm can activate external alarm or screen message prompt.  |
|                            | External Alarm           | Support record activation function or activate external alarm or screen message in specified period.   |
|                            | Manual Alarm Control     | Enable or disable alarm input channel<br>Support analog alarm signal to specific alarm output channel.   |
|                            | Alarm Input              | 7-ch alarm input (You can set normal open or normal close type to select the alarm type. )   |
|                            | Alarm Output             | 2-channel relay output.  |
| Interface                  | USB Interface            | 2 USB 2.0 ports.<br>One is at the front panel and the other is at the extension cable of the rear panel.   |
|                            | Network connection       | RJ45 10M/100M/1000M self-adaptable Ethernet port   |

|                            |                         |  |
|----------------------------|-------------------------|--|
|                            | RS485                   | PTZ control port<br>Support various PTZ control protocols.   |
|                            | RS232                   | Ordinary COM (Debug), keyboard connection and transparent serial port (COM input and output via network)   |
| Extension Function         | 3G                      | Built-in 3G module (EVDO, WCDMA). Support SMS online/offline activation. Audio online/offline activation. Front panel SIM card design and HDD lock protection. Optional 3G module. |
|                            | GPS                     | Built-in GPS/Baidou/GLONASS module. Support satellite positioning. Optional positioning system.  |
|                            | G-Sensor                | Built-in G-sensor module to detect acceleration speed at XYZ all directions.   |
|                            | Power Outage Protection | Built-in UPS support 5 seconds.  |
|                            | 0-channel encode        | Work with DSS platform to get the video from the 0-channel (4-window).   |
| System Information         | Hard Disk Information   | Display HDD current status   |
|                            | Data Stream Statistics  | Data stream statistics for each channel (in wave mode)   |
|                            | Log statistics          | Backup to 1024 log files.<br>Support various search engines such as time and type.   |
|                            | Version                 | Display version information: channel amount, alarm input and output amount, system version and release date.   |
|                            | On-line user            | Display current on-line user   |
| User Management            | User Management         | Multi-level user management; various management modes<br>Integrated management for local user, serial port user and network user.<br>Configurable user power.                      |
|                            |                         | Support user /group and its corresponding rights modification.<br>No limit to the user or group amount.  |
|                            | Password Authentication | Password modification<br>Administrator can modify other user's password.   |
|                            |                         | Account lock strategy<br>Five times login failure in thirty minutes may result in account lock.  |
| Upgrade                    |                         | Web browser, client-end and update tool.   |
| Login, Logout and Shutdown |                         | Password login protection to guarantee safety  |
|                            |                         | User-friendly interface when login. Provide the following options: Logout /shutdown/ restart.  |
|                            |                         | Right authentication when shut down to make sure only those proper people can turn off DVR   |
|                            | Power                   | DC 12V/24V DC built-in power supplying. Built-in UPS.  |

|                      |                     |  |
|----------------------|---------------------|--|
| General<br>Parameter | Power Consumption   | ≤15W (Exclude HDD/camera)  |
|                      | Working Temperature | -10℃~60℃   |
|                      | Working Humidity    | 10%—90%  |
|                      | Air Pressure        | 86kpa—106kpa   |
|                      | Dimension           | 1DIN standard industrial case.<br>Front panel: 190*210*60.<br>Rear panel: 180*210*50 |
|                      | Weight              | ≤2.1Kg(Exclude HDD)  |
|                      | Installation Mode   | Desktop installation   |

## 2 Front Panel and Rear Panel

### 2.1 Front Panel

The front panel is shown as in Figure 2-1.

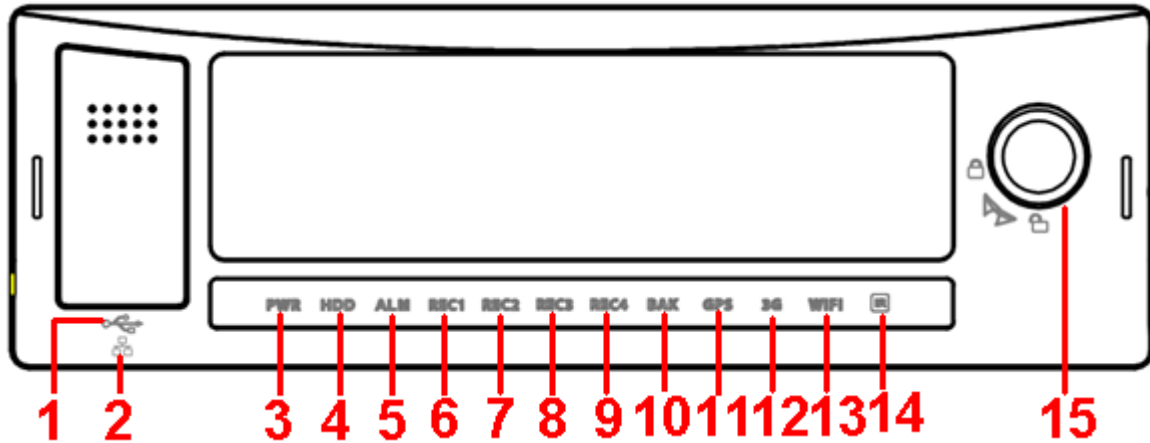

Figure 2-1

Please refer to the following sheet for detailed information.

| SN  | Name   | Function   |
|-----|--|--|
| 1   | USB port   | USB port. Connect to mouse or flash drive to copy data.  |
| 2   | RJ45 port  | Network port.  |
| 3   | Power indicator light.   | The light becomes on when device is connected to the power supplying.  |
| 4   | HDD indicator light  | The blue light is on when there is HDD. The light is off when there is no HDD.   |
| 5   | Alarm indicator light  | The blue light becomes on when there is any alarm.   |
| 6-9 | Record indicator light 1-4.  | The blue light becomes on when system is recording.  |
| 10  | Backup indicator light   | <ul style="list-style-type: none"> <li>The light becomes flash when system is backing up.</li> <li>The light is on when the backup is complete.</li> <li>The light is off when there is backup error or the flash drive is removed.</li> </ul> |
| 11  | GPS indicator light.<br><b>Please note only the unit of GPS module supports this function.</b> | The blue light is on when GPS positioning function is OK.  |
| 12  | 3G indicator light.<br><b>Please note only the unit of</b>                                     | The blue light is on when 3G dial function is OK.  |

|    |  |   |
|----|--|---|
|    | <b>3G module supports this function.</b>   |   |
| 13 | WIFI indicator light.<br><b>Please note only the unit of WIFI module supports this function.</b> | The blue light is on when WIFI connection is OK.  |
| 14 | Remote control receiver  | It is to receive signal from the remote control.  |
| 15 | Locker (Device on/off button)  | Before you remove the HDD, please unlock the device. System can not boot up right now.<br>System can only restart after you lock the device here. It is for HDD safety. |

## 2.2 Rear Panel

The rear panel is shown as in Figure 2-2.

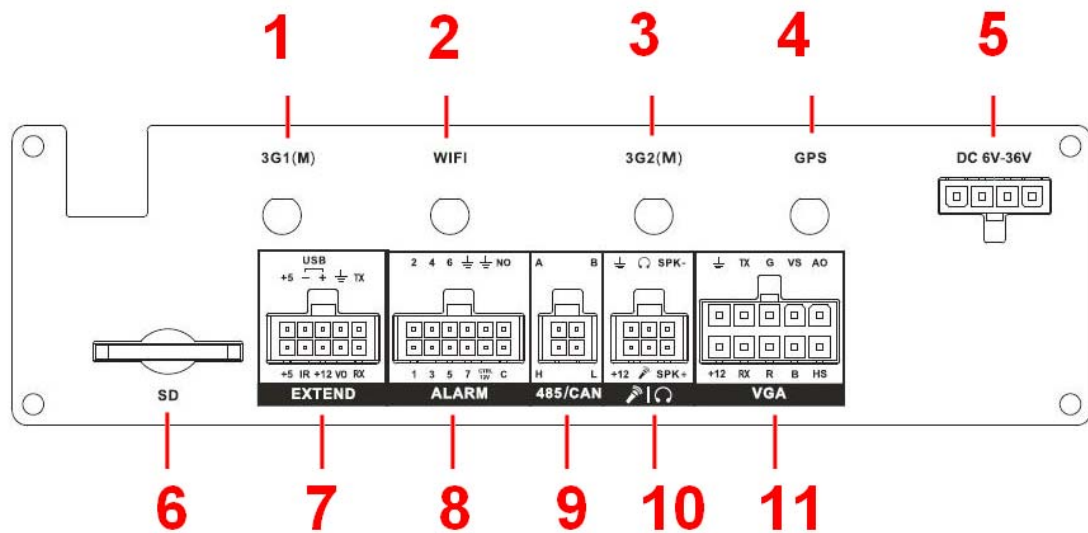

Figure 2-2

Please refer to the following sheet for front panel button information.

| SN | Name   | Function  |
|----|--|---|
| 1  | 3G1 antenna port<br><b>Please note only the unit of 3G module supports this function.</b>      | 3G antenna port   |
| 2  | WIFI antenna port<br><b>Please note only the unit of WIFI module supports this function.</b>   | WIFI antenna port   |
| 3  | 3G2 antenna port<br><b>Please note only the unit of dual-3G module supports this function.</b> | The second 3G antenna port.(It is for duak-3G mode only). |
| 4  | GPS port<br><b>Please note only the unit of GPS module supports this function.</b>             | GPS port  |
| 5  | Device power input.  | Device power input port.                                  |

|    |                              |  |
|----|------------------------------|--|
| 6  | SD card slot                 | SD card slot   |
| 7  | Extension port               | Extension port. Please refer to Figure 2-3 for detailed information.   |
| 8  | Alarm input/output port      | Alarm input/output port, GND port, and 12V output. Please refer to chapter 3.5 for detailed information.                                     |
| 9  | RS485 and CAN BUS port.      | RS485 communication port. It can control PTZ.<br>Reserved port. For data exchange between vehicle CAN network and other devices of CAN port. |
| 10 | Audio input and output port. | Bidirectional input and output port. Please refer to Figure 2-4 for detailed information.  |
| 11 | VGA port                     | VGA port It includes all kinds of VGA signal port. Please refer to Figure 2-5 for detailed information.                                      |

**Extension Port**

The extension port is shown as in Figure 2-3.

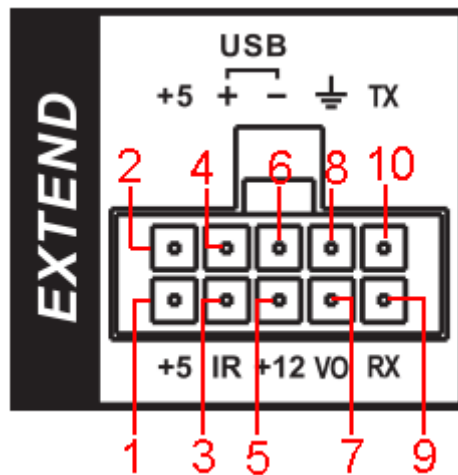

Figure 2-3

Please refer to the following sheet for detailed information.

| SN  | Function             |
|-----|----------------------|
| 1/2 | 5V output            |
| 3   | Remote control input |
| 4/6 | USB                  |
| 5   | +12V output          |
| 7   | Video output         |
| 8   | GND                  |

|    |         |
|----|---------|
| 9  | RXD_232 |
| 10 | TXD_232 |

**Audio input/output**

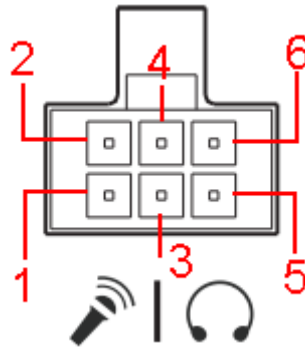

Figure 2-4

Please refer to the following sheet for detailed information.

| SN  | Function                            |
|-----|-------------------------------------|
| 1   | 12V/1A                              |
| 2   | GND                                 |
| 3   | MIC IN (Bidirectional talk input)   |
| 4   | MIC OUT (Bidirectional talk output) |
| 5/6 | Speaker+, speaker-                  |

**VGA Port**

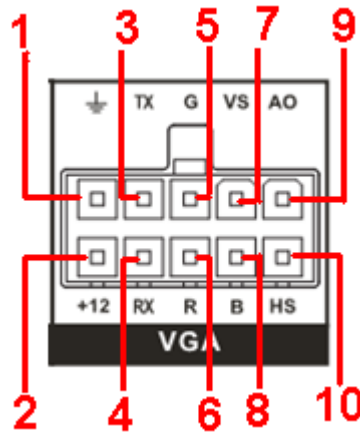

Figure 2-5

Please refer to the following sheet for detailed information.

| SN | Function    |
|----|-------------|
| 1  | GND         |
| 2  | +12V output |
| 3  | RXD_232     |
| 4  | TXD_232     |

| SN | Function                               |
|----|--|
| 5  | VGA signal Green                       |
| 6  | VGA signal Red                         |
| 7  | VGA signal field synchronization       |
| 8  | VGA signal Blue                        |
| 9  | AV signal video output                 |
| 10 | VGA signal horizontal synchronization. |

## 2.3 Remote Control

The remote control interface is shown as in Figure 2-1.

Please note remote control is not our standard accessory and it is not included in the accessory bag.

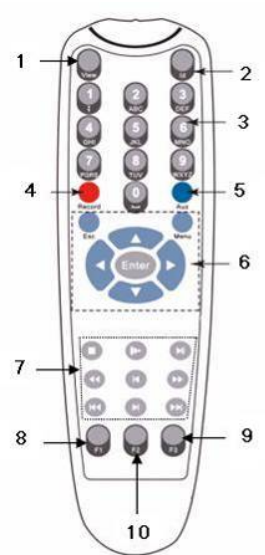

Figure 2-1

| Serial Number | Name          | Function   |
|---------------|---------------|--|
| 1             | View          | Switch window  |
| 2             | ID            | Click it to input device serial number, so that you can control it |
| 3             | Number 0 to 9 | Input password, channel or switch channel.                         |
| 4             | Record        | Record   |
| 5             | Aux           | Auxiliary button   |
| 6             | Enter         | Confirm button   |
|               | Menu          | Menu button  |
|               | Esc           | Cancel button  |

|    |               |   |
|----|---------------|---|
|    | ▲<br>◀ ▶<br>▼ | Direction buttons<br>Direction buttons in PTZ. Control.                                 |
| 7  | ■             | Stop button<br>Zoom out button in the PTZ control                                       |
|    | ▶             | Slow play   |
|    | ▶             | Playback/pause<br>Zoom in button in the PTZ control                                     |
|    | ◀◀            | Backward  |
|    | ◀             | Previous  |
|    | ▶▶            | Forward   |
|    | ◀◀            | Various slow play speed and normal speed play.<br>Focus (-) button in the PTZ control.  |
|    | ▶             | Next  |
|    | ▶▶            | Various fast play speeds and normal play speed.<br>Focus (+) button in the PTZ control. |
| 8  | F1            | Shortcut button to backup   |
| 9  | F2            | Shortcut button to update.  |
| 10 | F3            | Shortcut button to reboot.  |

## 2.4 Mouse Operation

Please refer to the following sheet for mouse operation instruction.

|                  |  |
|------------------|--|
| Left click mouse | When you have selected one menu item, left click mouse to view menu content. |
|                  | Modify checkbox or motion detection status.                                  |
|                  | Click combo box to pop up dropdown list                                      |

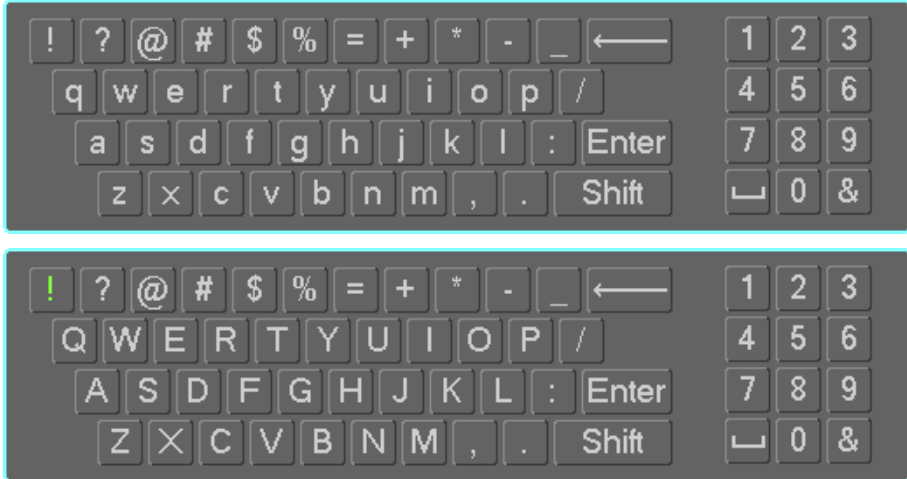
|                         |  |
|-------------------------|--|
|                         | <p>In input box, you can select input methods. Left click the corresponding button on the panel you can input numeral/English character (small/capitalized). Here ← stands for backspace button. _ stands for space button.</p> <p>In English input mode: _stands for input a backspace icon and ← stands for deleting the previous character.</p>  <p>In numeral input mode: _ stands for clear and ← stands for deleting the previous numeral.</p> |
| Double left click mouse | <p>Implement special control operation such as double click one item in the file list to playback the video.</p> <p>In multiple-window mode, double left click one channel to view in full-window. Double left click current video again to go back to previous multiple-window mode.</p>  |
| Right click mouse       | <p>In real-time monitor mode, pops up shortcut menu.</p> <p>Exit current menu without saving the modification.</p>   |
| Press middle button     | <p>In numeral input box: Increase or decrease numeral value.</p> <p>Switch the items in the check box.</p> <p>Page up or page down</p>   |
| Move mouse              | <p>Select current control or move control</p>  |
| Drag mouse              | <p>Select motion detection zone</p> <p>Select privacy mask zone.</p>   |

### 3 Installation and Connections

**Note:** All the installation and operations here should conform to your local electric safety rules.

#### 3.1 Check Unpacked DVR

When you receive the DVR from the forwarding agent, please check whether there is any visible damage. Please follow the sheet listed below.

| SN | Item             |  | Check Contents  |
|----|------------------|--|---|
| 1  | Whole package    | Appearance                                   | Is there nay visible damage or not.   |
|    |                  | Package                                      | Is there any accidental crash or not.   |
|    |                  | Accessories                                  | All items listed are included in the box or not.  |
| 2  | Front/rear panel | The model on the front panel                 | Check according to your purchase order.   |
|    |                  | The label on the rear panel.                 | <b>The label in the rear panel is very important too. Usually we need you to represent the serial number when we provide the service after sales.</b> |
| 3  | Case             | Appearance                                   | Is there nay visible damage or not.   |
|    |                  | Data cable, power cable, fan and main board. | They are firmly secured or not.<br>If there is any problem, contact your local retailer ASAP.   |

**Note**

Remote control is not a standard accessory and it is not included in the accessory bag.

#### 3.2 HDD Installation

The unit you received has no HDD. Please remove the HDD box from the device and then follow the steps listed below to install.

**Before the HDD installation, please unplug the power cable. Do not insert or remove the HDD when the system is running.**

**After the installation, please format HDD first (See chapter 4.8.1 HDD Management) and the use. Otherwise, you can see system beeps and display HDD error information.**

- 1) Check HDD box and components. See Figure 3-1.It includes HDD box bottom board and secure screws.

**HDD box bottom board secure screws**

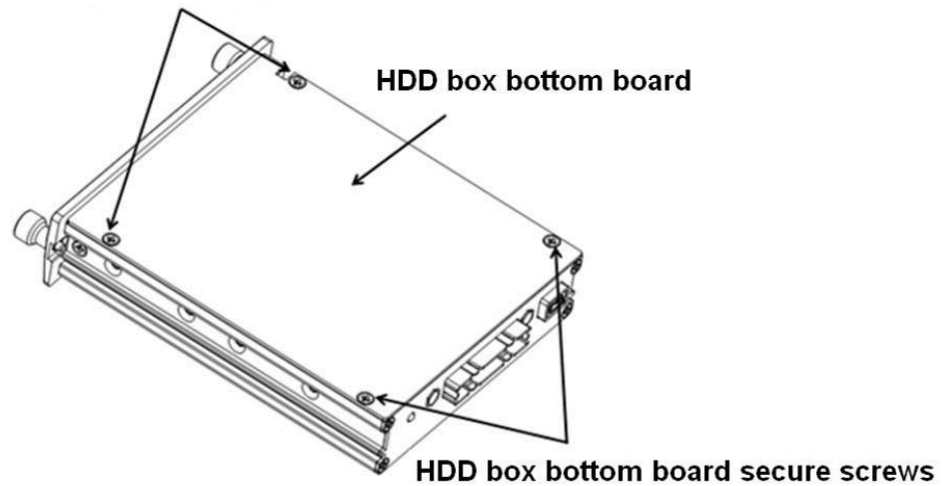

Figure 3-1

2) Remove screws of the HDD box bottom board and dismantle the HDD box bottom board. See Figure 3-2 .

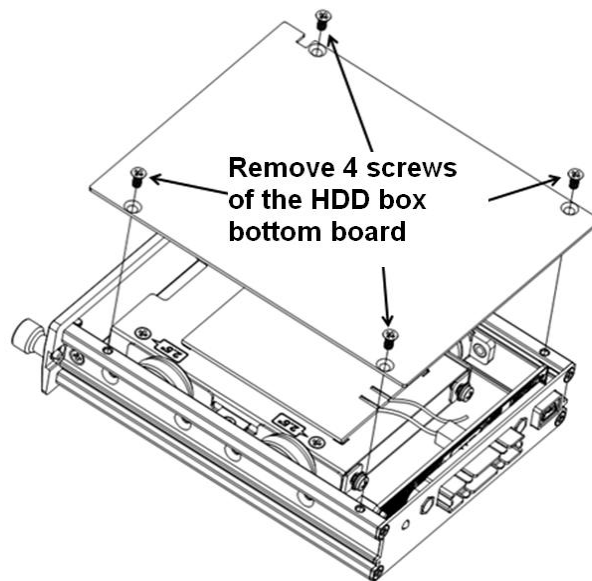

Figure 3-2

3) Use four screws to fix the HDD and the bracket and then use two screws to secure the bracket and the bottom board.

4) Use screws to fix the HDD box bottom board. The installation now is complete. See Figure 3-3.

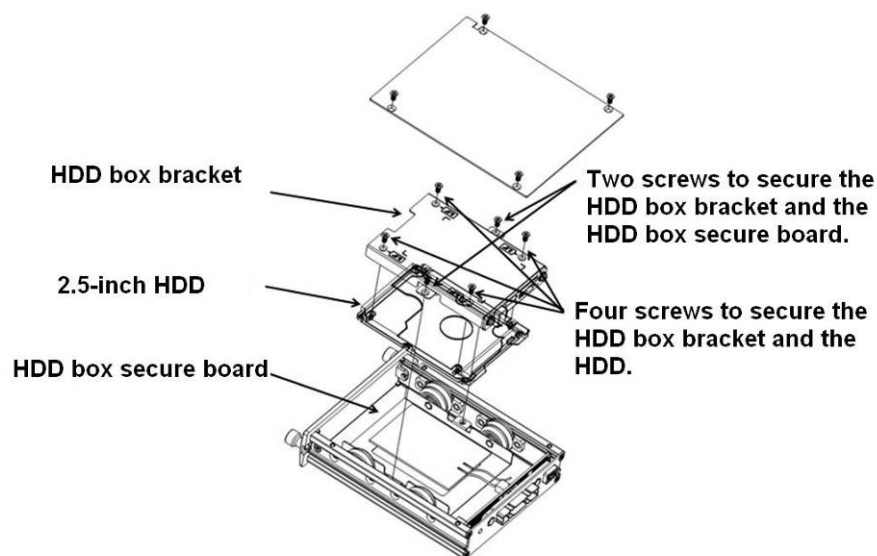

Figure 3-3

### SIM Card Installation

Please follow the steps listed below to install SIM card. See Figure 3-4.

- 1) Remove the HDD bracket.
- 2) Open SIM card slot.
- 3) Insert SIM card to the slot and then close slot cover.

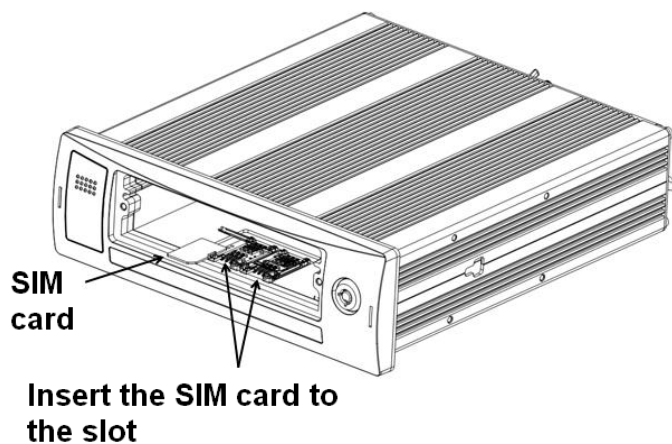

Figure 3-4

## 3.3 Connecting Power Supply

Please check input voltage and device power button match or not.

We recommend you use UPS to guarantee steady operation, DVR life span, and other peripheral equipments operation such as cameras.

## 3.4 Connecting Audio/Video Input and Output Devices

### 3.4.1 Connecting Video Input

The video signal should comply with your national standards.

The input video signal shall have high SNR, low distortion; low interference, natural color and suitable lightness.

**Guarantee the stability and reliability of the camera signal:**

The camera shall be installed in a cool, dry place away from direct sunlight, inflammable, explosive substances and etc.

The camera and the DVR should have the same grounding to ensure the normal operation of the camera.

**Guarantee stability and reliability of the transmission line**

Please use high quality, sound shielded BNC. Please select suitable BNC model according to the transmission distance.

If the distance is too long, you should use twisted pair cable, and you can add video compensation devices or use optical fiber to ensure video quality.

You should keep the video signal away from the strong electromagnetic interference, especially the high tension current.

**Keep connection lugs in well contact**

The signal line and shielded wire should be fixed firmly and in well connection. Avoid dry joint, lap welding and oxidation.

### 3.4.2 Audio Input

Due to high impedance of audio input, please use active sound pick-up.

Audio transmission is similar to video transmission. Try to avoid interference, dry joint, loose contact and it shall be away from high tension current.

The 4-pin aviation-level port is shown as below. It is to input the audio and video. See Figure 3-5.

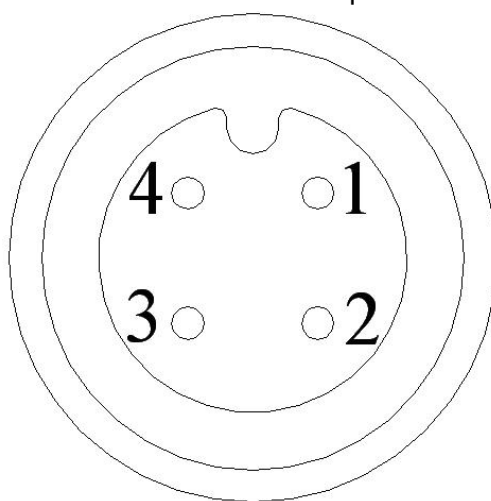

Figure 3-5

Please refer to the following sheet for detailed information.

| SN | Function                                   |
|----|--|
| 1  | 12V external camera power. Less than 1.5A. |
| 2  | GND  |
| 3  | Audio port                                 |
| 4  | Video port.                                |

The audio input cable is shown as in Figure 3-6. Please use this cable when your camera is the general BNC port.

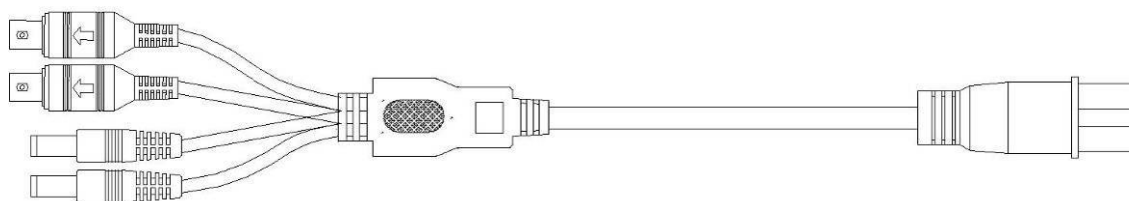

Figure 3-6

Please refer to the following sheet for detailed information.

| Audio/Video input cable (Aviation port 4p male port) |  |
|--|--|
| Port   | Color and Definition   |
| 1  | Yellow BNC male port (Video input)   |
| 2  | White BNC male port (Audio input)  |
| 3  | DC power male socket external is negative and internal is positive (Camera power output) |
| 4  | DC power male socket external is negative and internal is positive (Camera power output) |

### 3.4.3 Connecting Video Output

Video output includes a CVBS(PAL/NTSC BNC (1.0VP- P, 75Ω) output and a VGA output. System supports CVBS and VGA output at the same time.

When you are using pc-type monitor to replace the monitor, please pay attention to the following points:

- To defer aging, do not allow the pc monitor to run for a long time.
- Regular demagnetization will keep device maintain proper status.
- Keep it away from strong electromagnetic interference devices.

Using TV as video output device is not a reliable substitution method. You also need to reduce the working hour and control the interference from power supply and other devices. The low quality TV may result in device damage.

**Note:**

**You need a switch cable if you want to use VGA output.**

### 3.4.4 Audio Output

The audio output signal parameter is usually over 200mv 1KΩ (BNC). It can directly connect to low impedance earphone, active sound box or amplifier-drive audio output device.

If the sound box and the pick-up cannot be separated spatially, it is easy to arouse squeaking. In this case you can adopt the following measures:

- Use better sound pick-up with better directing property.
- Reduce the volume of the sound box.

- Using more sound-absorbing materials in decoration can reduce voice echo and improve acoustics environment.
- Adjust the layout to reduce happening of the squeaking.

Please refer to Figure 3-7 for 4-pin aviation port cable information. It is for audio and video output.

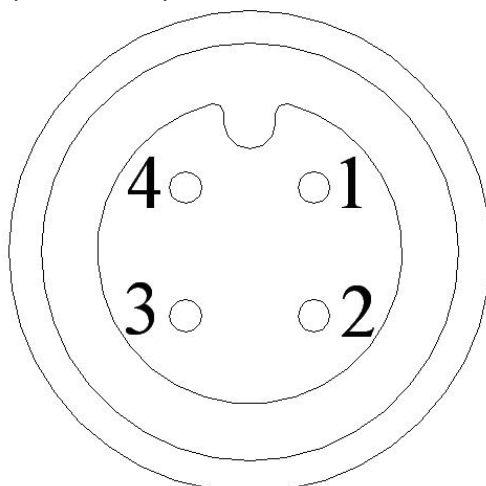

Figure 3-7

Please refer to the following sheet for detailed information.

| SN | Function   |
|----|--|
| 1  | 12V external camera power. It is less than 1.5A. |
| 2  | GND  |
| 3  | Audio port                                       |
| 4  | Video port                                       |

Audio/video output cable is shown as below. See Figure 3-8. You can use it when your monitor port is general BNC port.

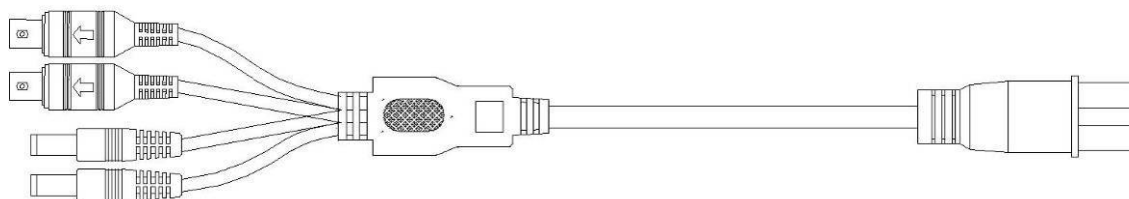

Figure 3-8

Please refer to the following sheet for detailed information.

| Audio/Video Output Cable (Aviation-level port 4p male socket ) |   |
|--|---|
| Socket   | Color and Definition                                    |
| 1  | Yellow BNC male port ( Video output )                   |
| 2  | White BNC male port ( Audio output )                    |
| 3  | DC power male socket. External is negative and internal |

|   |   |
|---|---|
|   | is positive.<br>( 12V power output )  |
| 4 | DC power male socket. External is negative and internal<br>is positive.<br>( 12V power output ) |

**Note**

For some special series products, you need contact your local retailer for additional audio/video output cable.

### 3.5 Alarm Input and Output Connection

There are two alarm input types for you to select: normal open (NO) and normal close (NC).

**1. Alarm input**

- a. Alarm input mode supports grounding alarm input.
- b. Alarm input supports 12V-24V voltage signal alarm input.
- c. When the alarm device is connecting one DVR and one other device, please use a relay to separate them,

**2. Alarm output**

The alarm output port should not be connected to high power load directly (It shall be less than 1A) to avoid high current which may result in relay damage. Please use the co contactor to realize the connection between the alarm output port and the load.

**3. How to connect PTZ decoder**

- a. Ensure the decoder has the same grounding with DVR, otherwise you may not control the PTZ. Shielded twisted wire is recommended and the shielded layer is used to connect to the grounding.
- b. Avoid high voltage. Ensure proper wiring and some thunder protection measures.
- c. For too long signal wires, 120Ω should be parallel connected between A, B lines on the far end to reduce reflection and guarantee the signal quality.
- d. “485 A, B” of DVR cannot parallel connect with “485 port” of other device.
- e. The voltage between of A,B lines of the decoder should be less than 5v.

**4. Please make sure the front-end device has soundly earthed.**

Improper grounding may result in chip damage.

#### 3.5.1 Alarm Input and Output Details

Alarm input and output interface is shown as in Figure 3-9.

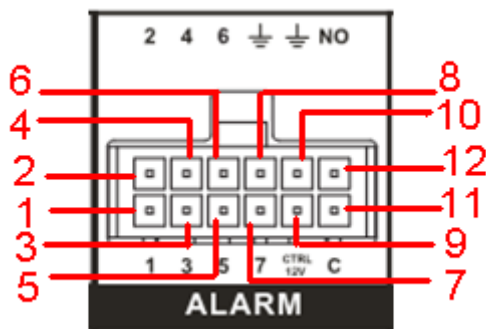

Figure 3-9

Please refer to the following sheet for detailed information.

| SN    | Function                |
|-------|-------------------------|
| 1-7   | Alarm input 1-7         |
| 8/10  | Alarm GND               |
| 9     | Controllable 12V output |
| 10/11 | NO, C of alarm output 2 |

Bidirectional talk port interface is shown as in Figure 3-10.

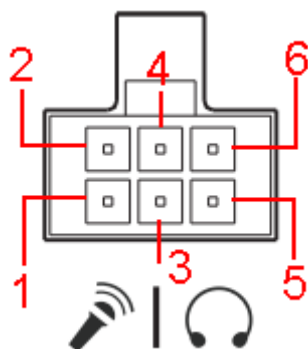

Figure 3-10

Please refer to the following sheet for detailed information.

| SN  | Function           |
|-----|--------------------|
| 1   | 12V/1A             |
| 2   | GND                |
| 3   | MIC IN             |
| 4   | MIC OUT            |
| 5/6 | Speaker+, speaker- |

### 3.5.2 Alarm Input Port

Please refer to the following sheet for more information. See Figure 3-11.

- Normal open or Normal close type.

- Please parallel connect COM end and GND end of the alarm detector (Provide external power to the alarm detector).
- Please parallel connect the Ground of the DVR and the ground of the alarm detector.
- Please connect the NC port of the alarm sensor to the DVR alarm input(ALARM)
- Use the same ground with that of DVR if you use external power to the alarm device.

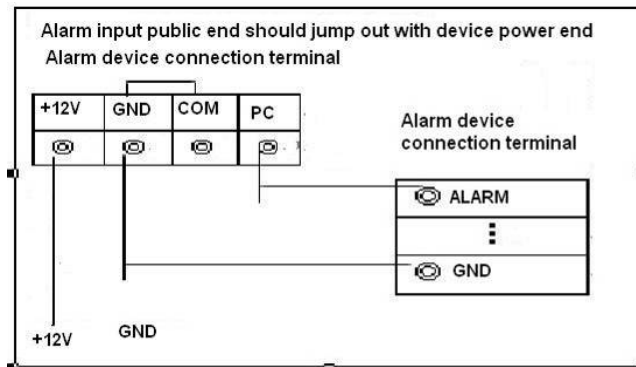

Figure 3-11

### 3.5.3 Alarm Output Port

- 2 ways relay alarm output (NO contact). Provide external power to external alarm device.
- To avoid overloading, please read the following relay parameters sheet carefully.
- RS485 A/B cable is for the A/B cable of the PTZ decoder.

#### Relay Specification

| Model: HFD23             |                       |                                 |              |
|--------------------------|-----------------------|---------------------------------|--------------|
| Contact<br>Parameter     | Contact mode          | 1Z                              |              |
|                          | Contact resistance    | 100mΩ(0.1A 6VDC)                |              |
|                          | Contact material      | AgNi+gold-plating               |              |
|                          | Contact               | 0.5A 125VAC/1A 30VDC            |              |
|                          | Max switch voltage    | 125VAC / 60VDC                  |              |
|                          | Max switch current    | 2A                              |              |
|                          | Max switch power      | 62.5VA/30W                      |              |
|                          | Min allowed load      | 1mA 5V                          |              |
|                          | Mechanical durability | 1x10 <sup>7</sup> (300/min)     |              |
|                          | Electric durability   | 1x10 <sup>5</sup> (30/min)      |              |
| Performance<br>Parameter | Insulation resistance | 1000MΩ(500VDC)                  |              |
|                          | Media<br>pressure     | Between<br>loop and             | 1000VAC 1min |
|                          |                       | Between<br>separated<br>contact | 400VAC 1min  |

|      |                                      |   |
|------|--------------------------------------|---|
|      | Operation time (Rated voltage)       | ≤5ms  |
|      | Release time (Rated voltage)         | ≤5ms  |
|      | Bound time (Rated voltage)           | About 5ms                                     |
|      | Loop temperature rise(Rated voltage) | ≤65K  |
|      | Strike                               | 98m/s <sup>2</sup>                            |
|      | Vibration                            | 10Hz~55 Hz 3.3mm Double amplitude             |
|      | Humidity                             | 98% RH, 40℃                                   |
|      | Temperature                          | -30℃~70℃                                      |
|      | Weight                               | About 2.2g                                    |
|      | leading-out end mode                 | DIP   |
|      | Seal mode                            | Sealed  |
| Loop | Rated Loop Power                     | Standard mode: 200mW; Sensitivity mode: 150mW |

**Please note the number in the above sheet is the initial value.**

## 4 GUI Operation

Connect the device to the monitor and then connect a mouse and power cable. Turn the key to the  level; you can see the power indicator light is on. The device begins boot up. The process may take a little bit time. Please be patient.

### 4.1 Login

After device booted up, the system is in multiple-channel display mode by default. See Figure 4-1.



Figure 4-1

Right click mouse, you can see login interface. See Figure 4-2.

System consists of four accounts:

- **Username:** admin. **Password:** admin. (administrator, local and network)
- **Username:** 888888. **Password:** 888888. (administrator, local only)
- **Username:** 666666. **Password:** 666666(Lower authority user who can only monitor, playback, backup and etc.)
- **Username:** default. **Password:** default(hidden user)

You can use USB2.0 mouse to input. Click  to switch between numeral, English character (small/capitalized) and denotation.

**Note:**

**For security reason, please modify password after you first login.**

Continuous three times login failure will result in system alarm and five times login failure will result in account lock.

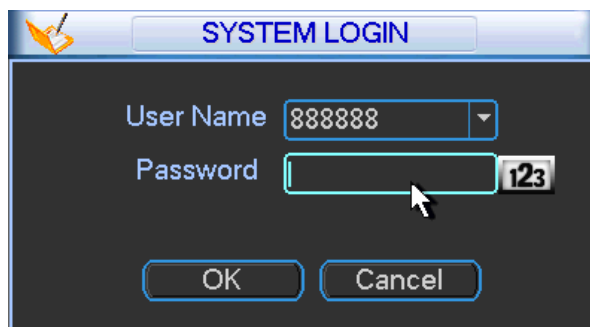





Figure 4-2

You can overlay the corresponding date, time and channel name on each screen. You can refer to the following sheet for channel record or alarm status information.

|   |   |                  |   |   |             |
|---|---|------------------|---|---|-------------|
| 1 |  | Recording status | 3 |  | Video loss  |
| 2 |  | Motion detection | 4 |  | Camera lock |

### **Preview Control**

The preview control function has the following features.

- Support preview playback.
  - ✧ In the preview desktop, system can playback previous 5-60 minutes record of current channel. Please go to the Main Menu->General to set real-time playback time.
  - ✧ Support drag and play function. You can use your mouse to select any playback start time.
  - ✧ Support playback, pause and exit function.
  - ✧ Right now, system does not support slow playback and backward playback function.
- Support digital zoom function.
- Support real-time backup function.

You can follow the contents listed below for the operation instruction.



### **Preview control interface**



Move your mouse to the top centre of the video of current channel, you can see system pops up the preview control interface. See Figure 4-3. If your mouse stays in this area for more than 6 seconds and has no operation, the control bar automatically hides.



Figure 4-3

You can refer to the following sheet for detailed information.

| SN | Name                      | Function   |
|----|---------------------------|--|
| 1  | Realtime playback         | It is to playback the previous 5-60 minutes record of current channel.<br>Please go to the Main Menu->General to set real-time playback time.<br>System may pop up a dialogue box if there is no such record in current channel.   |
| 2  | Digital zoom              | It is to zoom in specified zone of current channel. It supports zoom in function of multiple-channel.<br><br>The selected area has an icon as  and the free area is shown as an icon as  . |
| 3  | Real-time backup function | It is to backup the video of current channel to the USB device. System can not backup the video  |

|   |      |   |
|---|------|---|
|   |      | <p>of multiple-channel at the same time.<br/> Current selected backup channel has an icon as  and the free channel is shown as an icon as  .</p> <p>Once the backup started, you can see the free channel is shown as an icon as .</p> |
| 4 | Exit |   |

### **Playback control**

The playback control has the following features.

- Support play, pause, and exit and drag function.
- During the preview playback process, you can not see the channel title and record status of current channel. It will display the channel title and the record status once you exit the preview playback.
- During the preview playback, you can not switch the displayed channel or change current window-display mode.

## **4.2 Navigation Bar**

The navigation bar is shown as in Figure 4-4.



Figure 4-4

- ① Main Interface: Click it to go to main menu interface.
- ② Window split: Here you can select 1/4-window output mode. Please click one button and then select the corresponding channel(s).
- ③ PTZ: Click it to go to the PTZ operation interface. Please refer to chapter 4.7.8 for detailed information.
- ④ Search: It is the record search shortcut menu. Please refer to chapter 4.5 for detailed information.
- ⑤ Alarm status: Click it to go to the alarm status interface to set alarm information of current channel.
- ⑥ Network status: It is the network setup shortcut button. Please refer to chapter 4.7.5 for detailed information.
- ⑦ HDD Manager: It is the HDD manager shortcut button. Please refer to chapter 4.8.1 for detailed information.

## **4.3 Right Click Menu**

After you logged in the device, right click mouse, you can see the short cut menu. Please see Figure 4-5.

Here you can set local playback window, PTZ control, video color, search records and etc. The local playback window includes 1/4.

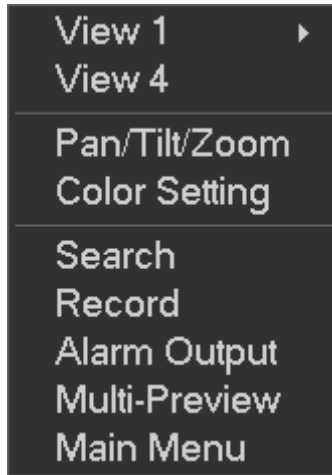

Figure 4-5

## 4.4 Main Menu

After you logged in, the system main menu is shown as below. See Figure 4-6. There are total six icons: search, Information, setting, backup, advanced and shutdown. Move the cursor to highlight the icon, then double click mouse to enter the sub-menu.

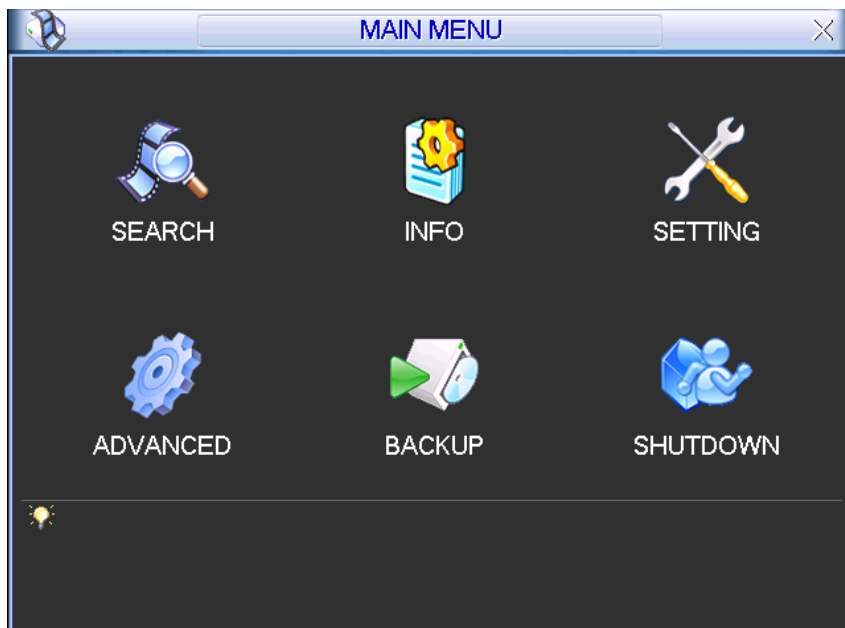

Figure 4-6

## 4.5 Search & Playback

Click search button in the main menu, search interface is shown as below. See Figure 4-7.

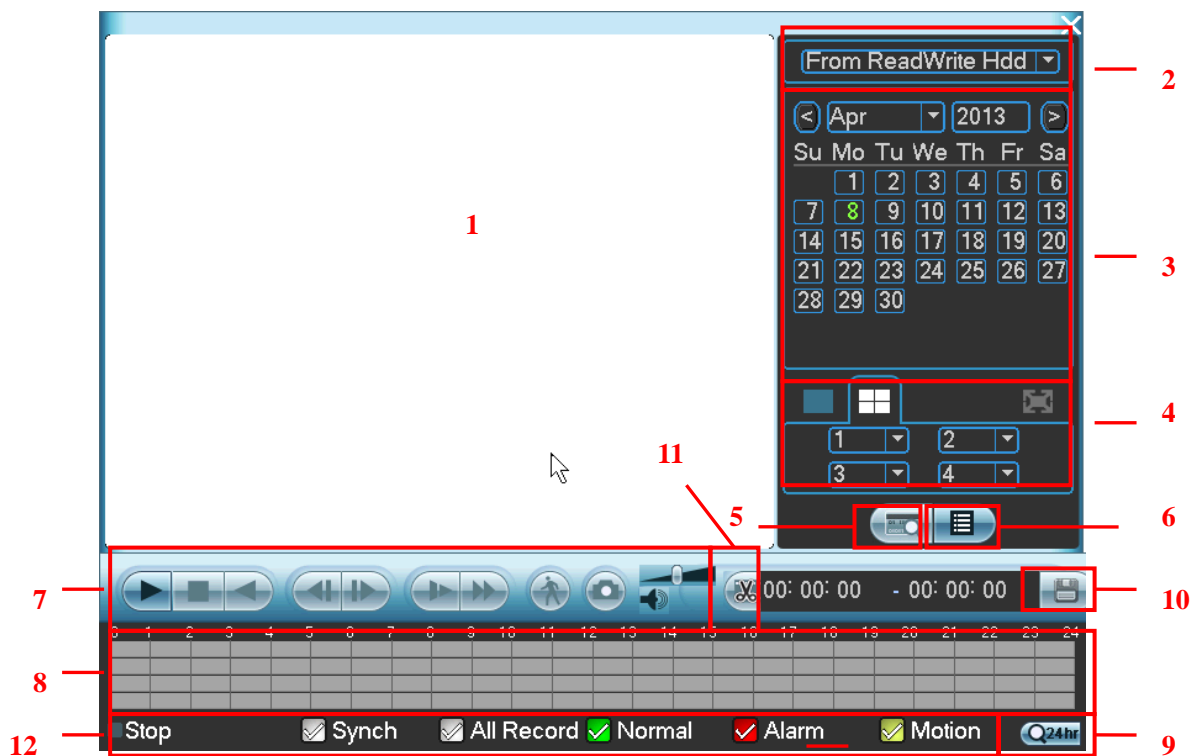









Figure 4-7

Please refer to the following sheet for more information.

| SN | Name                                      | Function  |
|----|---|---|
| 1  | Display window                            | <ul style="list-style-type: none"> <li>● Here is to display the searched picture or file.</li> <li>● Support 1/4-window playback.</li> </ul>  |
| 2  | Search type                               | <ul style="list-style-type: none"> <li>● Here you can select to search the picture or the recorded file.</li> <li>● You can select to play from the read-write HDD, from peripheral device or from redundancy HDD.</li> <li>● Before you select to play from the peripheral device, please connect the corresponding peripheral device. You can view all record files of the root directory of the peripheral device. Click the Browse button; you can select the file you want to play.</li> </ul> <p><b>Important</b><br/>Redundancy HDD does not support picture backup function, but it supports picture playback function. You can select to play from redundancy HDD if there are pictures on the redundancy HDD.</p> |
| 3  | Calendar                                  | <ul style="list-style-type: none"> <li>● The blue highlighted date means there is picture or file. Otherwise, there is no picture or file.</li> <li>● In any play mode, click the date you want to see, you can see the corresponding record file trace in the time bar.</li> </ul>   |
| 4  | Playback mode and channel selection pane. | <ul style="list-style-type: none"> <li>● Playback mode: 1/4.</li> <li>◇ In 1-window playback mode: you can select 1-16 channels.</li> <li>◇ In 4-window playback mode: you can select 4 channels according to your requirement.</li> <li>● The time bar will change once you modify the playback mode or the channel option.</li> </ul>   |

|       |  |  |     |  |   |      |   |  |       |  |   |   |
|-------|--|--|-----|--|---|------|---|--|-------|--|---|---|
| 5     | File list switch button  | <ul style="list-style-type: none"> <li>● Double click it, you can view the picture/record file list of current day.</li> <li>● The file list is to display the first channel of the record file.</li> <li>● The system can display max 128 files in one time. Use the ▲/▼ or the mouse to view the file. Select one item, and then double click the mouse or click the ENTER button to playback.</li> <li>● You can input the period in the following interface to begin accurate search.</li> </ul>  <ul style="list-style-type: none"> <li>● File type: R—regular record; A—external alarm record; M—Motion detect record.</li> <li>● Lock file. Click the file you want to lock and click the button  to lock. The file you locked will not be overwritten.</li> <li>● Search locked file: Click the button  to view the locked file.</li> <li>● Return: Click button , system goes back to the calendar and channel setup interface.</li> </ul> <p><b>Please note:</b></p> <ul style="list-style-type: none"> <li>● System max locks 16 files. The size of the locked file shall be less than the 1/4 of the HDD total space. The first 16G of each partition can not be locked.</li> <li>● System can not lock the extra stream. For the file that is writing or overwriting, it can not be locked.</li> </ul>                                 |     |  |   |      |   |  |       |  |   |   |
| 6     | Mark file list button  | Click it to go to mark file list interface. You can view all mark information of current channel by time. Please refer to chapter 4.5.1 for detailed information.  |     |  |   |      |   |  |       |  |   |   |
| 7     | Playback control pane.   | <table border="1"> <tr> <td data-bbox="472 1281 555 1525">▶ /   </td> <td data-bbox="555 1281 1522 1525">           Play/Pause<br/>           There are three ways for you to begin playback.           <ul style="list-style-type: none"> <li>● The play button</li> <li>● Double click the valid period of the time bar.</li> <li>● Double click the item in the file list.</li> </ul>           In slow play mode, click it to switch between play/pause.         </td> </tr> <tr> <td data-bbox="472 1525 555 1570">■</td> <td data-bbox="555 1525 1522 1570">Stop</td> </tr> <tr> <td data-bbox="472 1570 555 1738">◀</td> <td data-bbox="555 1570 1522 1738">           Backward play<br/>           In normal play mode, left click the button, the file begins backward play. Click it again to pause current play.<br/>           In backward play mode, click ▶ /    to restore normal play.         </td> </tr> <tr> <td data-bbox="472 1738 555 1944">  ◀ / ▶  </td> <td data-bbox="555 1738 1522 1944">           In playback mode, click it to play the next or the previous section. You can click continuously when you are watching the files from the same channel.<br/>           In normal play mode, when you pause current play, you can click ◀   and   ▶ to begin frame by frame playback.<br/>           In frame by frame playback mode, click ▶ /    to restore normal playback.         </td> </tr> <tr> <td data-bbox="472 1944 555 2051">▶</td> <td data-bbox="555 1944 1522 2051">           Slow play<br/>           In playback mode, click it to realize various slow play modes such as slow play 1, slow play 2, and etc.         </td> </tr> </table> | ▶ / | Play/Pause<br>There are three ways for you to begin playback. <ul style="list-style-type: none"> <li>● The play button</li> <li>● Double click the valid period of the time bar.</li> <li>● Double click the item in the file list.</li> </ul> In slow play mode, click it to switch between play/pause. | ■ | Stop | ◀ | Backward play<br>In normal play mode, left click the button, the file begins backward play. Click it again to pause current play.<br>In backward play mode, click ▶ /    to restore normal play. | ◀ / ▶ | In playback mode, click it to play the next or the previous section. You can click continuously when you are watching the files from the same channel.<br>In normal play mode, when you pause current play, you can click ◀   and   ▶ to begin frame by frame playback.<br>In frame by frame playback mode, click ▶ /    to restore normal playback. | ▶ | Slow play<br>In playback mode, click it to realize various slow play modes such as slow play 1, slow play 2, and etc. |
| ▶ /   | Play/Pause<br>There are three ways for you to begin playback. <ul style="list-style-type: none"> <li>● The play button</li> <li>● Double click the valid period of the time bar.</li> <li>● Double click the item in the file list.</li> </ul> In slow play mode, click it to switch between play/pause.   |  |     |  |   |      |   |  |       |  |   |   |
| ■     | Stop   |  |     |  |   |      |   |  |       |  |   |   |
| ◀     | Backward play<br>In normal play mode, left click the button, the file begins backward play. Click it again to pause current play.<br>In backward play mode, click ▶ /    to restore normal play.   |  |     |  |   |      |   |  |       |  |   |   |
| ◀ / ▶ | In playback mode, click it to play the next or the previous section. You can click continuously when you are watching the files from the same channel.<br>In normal play mode, when you pause current play, you can click ◀   and   ▶ to begin frame by frame playback.<br>In frame by frame playback mode, click ▶ /    to restore normal playback. |  |     |  |   |      |   |  |       |  |   |   |
| ▶     | Slow play<br>In playback mode, click it to realize various slow play modes such as slow play 1, slow play 2, and etc.  |  |     |  |   |      |   |  |       |  |   |   |

|                        |               |  |
|------------------------|---------------|--|
|                        |               |  <p>Fast forward<br/>In playback mode, click to realize various fast play modes such as fast play 1, fast play 2 and etc.</p>   |
|                        |               | Note: The actual play speed has relationship with the software version.  |
|                        |               |  <p>Smart search</p>  |
|                        |               |  <p>The volume of the playback</p>  |
|                        |               |  <p>Click the snapshot button in the full-screen mode, the system can snapshot 1 picture per second.<br/>System supports custom snap picture saved path. Please connect the peripheral device first, click snap button on the full-screen mode, you can select or create path. Click Start button, the snapshot picture can be saved to the specified path.</p>   |
| 8                      | Time bar      | <ul style="list-style-type: none"> <li>● It is to display the record type and its period in current search criteria.</li> <li>● In 4-window playback mode, there are corresponding four time bars. In other playback mode, there is only one time bar.</li> <li>● Use the mouse to click one point of the color zone in the time bar, system begins playback.</li> <li>● The time bar is beginning with 0 o'clock when you are setting the configuration. The time bar zooms in the period of the current playback time when you are playing the file.</li> <li>● The green color stands for the regular record file. The red color stands for the external alarm record file. The yellow stands for the motion detect record file.</li> </ul> |
| 9                      | Time bar unit | <ul style="list-style-type: none"> <li>● The option includes: 24H, 12H, 1H and 30M. The smaller the unit, the larger the zoom rate. You can accurately set the time in the time bar to playback the record.</li> <li>● The time bar is beginning with 0 o'clock when you are setting the configuration. The time bar zooms in the period of the current playback time when you are playing the file.</li> </ul>  |
| 10                     | Backup        | <p>Select the file(s) you want to backup from the file list. System max supports files from four channels. Then click the backup button, now you can see the backup menu. Click the start button to begin the backup operation.<br/>Check the file again you can cancel current selection.<br/>System max supports to display 32 files from one channel.</p>   |
| 11                     | Clip          | <ul style="list-style-type: none"> <li>● It is to edit the file.</li> <li>● Please play the file you want to edit and then click this button when you want to edit. You can see the corresponding slide bar in the time bar of the corresponding channel. You can adjust the slide bar or input the accurate time to set the file end time. Click this button again and then save current contents in a new file.</li> </ul>   |
| 12                     | Record type   | In any play mode, the time bar will change once you modify the search type.  |
| <b>Other Functions</b> |               |  |

|    |  |  |
|----|--|--|
| 13 | Other channel synchronization switch to play when playback | When playing the file, click the number button, system can switch to the same period of the corresponding channel to play.   |
| 14 | Other channel synchronization switch to play when playback | When playing the file, click the number button, system can switch to the same period of the corresponding channel to play.   |
| 15 | Digital zoom   | When the system is in full-screen playback mode, left click the mouse in the screen. Drag your mouse in the screen to select a section and then left click mouse to realize digital zoom. You can right click mouse to exit. |
| 16 | Manually switch channel when playback                      | During the file playback process, you can switch to other channel via the dropdown list or rolling the mouse. This function is null if there is no record file or system is in smart search process.                         |

**Note:**

All the operations here (such as playback speed, channel, time and progress) have relationship with hardware version. Some series DVRs do not support some functions or playback speeds.

**4.5.1 Mark Playback**

**Please make sure your purchased device support this function. You can use this function only if you can see the mark playback icon on the Search interface (Figure 4-7).**

When you are playback record, you can mark the record when there is important information. After playback, you can use time or the mark key words to search corresponding record and then play. It is very easy for you to get the important video information.

- Add Mark

When system is playback, click Mark button , you can go to the following interface. See Figure 4-8.

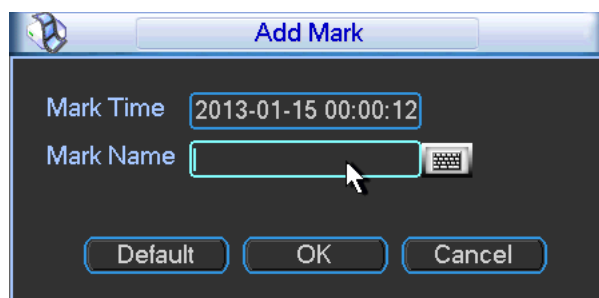



Figure 4-8

- Playback Mark

During 1-window playback mode, click mark file list button  in Figure 4-7, you can go to mark file list interface. Double click one mark file, you can begin playback from the mark time.

- Play before mark time

Here you can set to begin playback from previous N seconds of the mark time.

**Note**

Usually, system can playbacks previous N seconds record if there is such kind of record file.

Otherwise, system playbacks from the previous X seconds when there is such as kind of record.

- Mark Manager

Click the mark manager button  on the Search interface (Figure 4-7); you can go to Mark Manager interface. See Figure 4-9. System can manage all the record mark information of current channel by default. You can view all mark information of current channel by time.

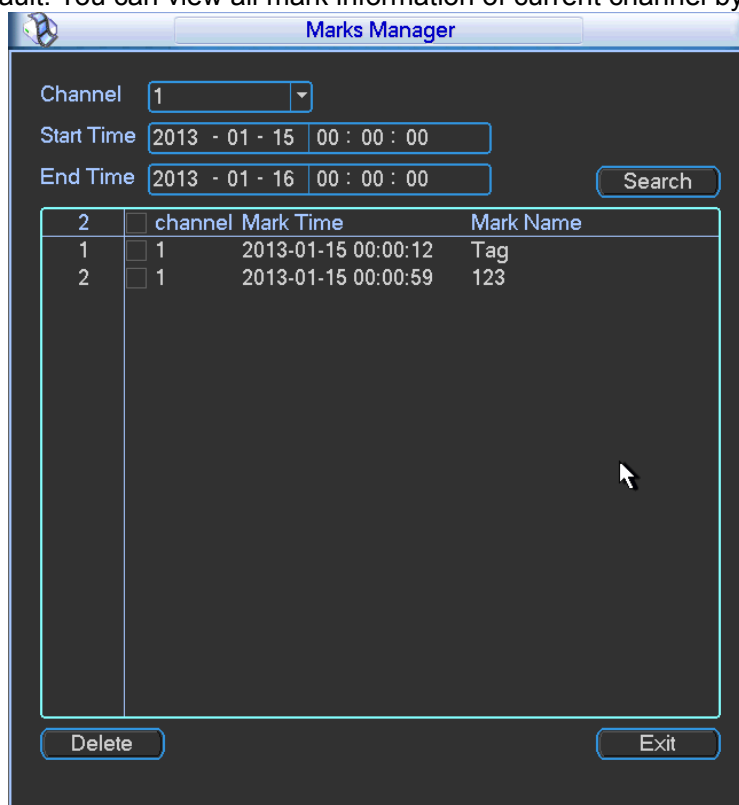

Figure 4-9

- Modify

Double click one mark information item, you can see system pops up a dialogue box for you to change mark information. You can only change mark name here.

- Delete

Here you can check the mark information item you want to delete and then click Delete button, you can remove one mark item. .

**Note**

- After you go to the mark management interface, system needs to pause current playback. System resume playback after you exit mark management interface.
- If the mark file you want to playback has been removed, system begin playbacking from the first file in the list.

## 4.6 Information

Here is for you to view system information. There are total six items: HDD (hard disk information), BPS (data stream statistics), log, version, online user and network information. See Figure 4-10.

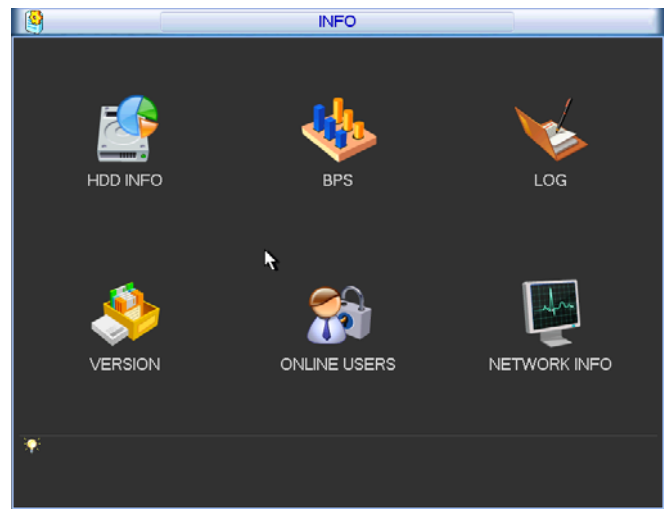

Figure 4-10

**4.6.1 HDD Information**

Here is to list hard disk type, total space, free space, and status. See Figure 4-11.

○ means current HDD is normal.. - means there is no HDD.

If disk is damaged, system shows as “?”. Please remove the broken hard disk before you add a new one.

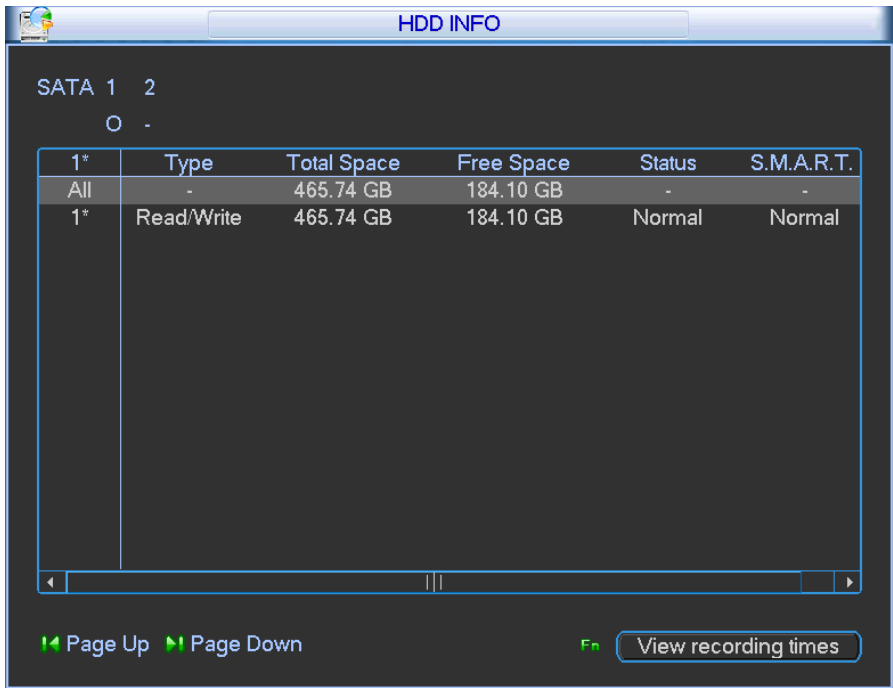

Figure 4-11

In Figure 4-11, click one HDD information item, SMART information interface is shown as in Figure 4-12.

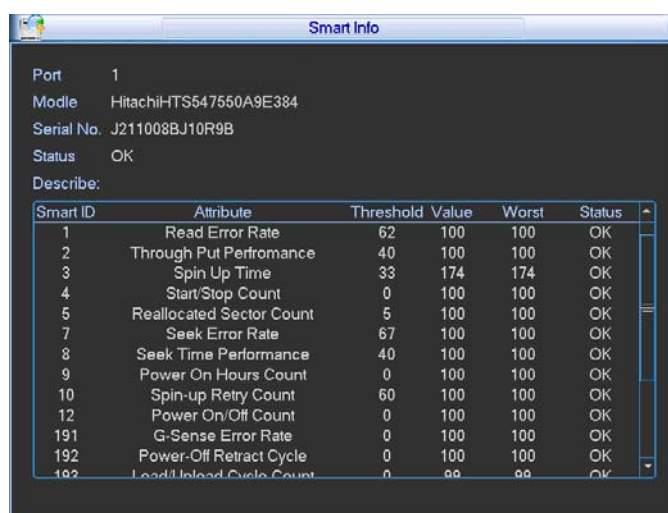

Figure 4-12

**Tips:**

Please click AUX button or use mouse to left click View record time button to view HDD record time and HDD type and time.

| Parameter                    | Function   |
|------------------------------|--|
| SATA                         | 2 here means system max supports 2 HDDs.<br>When HDD is working properly, system is shown as O. . “_” means there is no HDD. |
| SN                           | You can view the HDD amount the device connected to;<br>* means the second HDD is current working HDD.                       |
| Type                         | The corresponding HDD property.  |
| Total space                  | The HDD total capacity.  |
| Free space                   | The HDD free capacity.   |
| Status                       | HDD can work properly or not.  |
| Bad track                    | Display there is bad track or not.   |
| Page up                      | Click it to view previous page.  |
| Page down                    | Click it to view the next page.  |
| View recording time          | Click it to view HDD record information (file start time and end time).  |
| View HDD type and capability | Click it to view HDD property, status and etc,   |

**4.6.2 BPS**

Here is for you to view current video data stream (kbit/s) and occupied hard disk storage (MB/H).

See Figure 4-13.

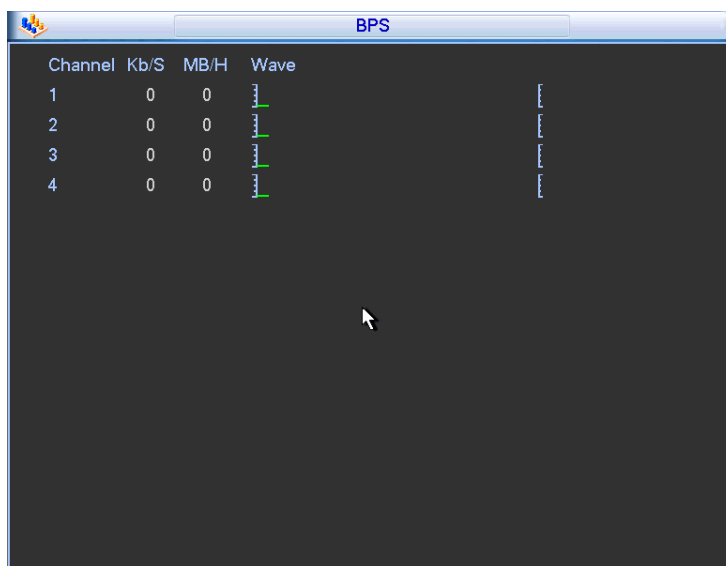







| Channel | Kb/S | MB/H | Wave  |
|---------|------|------|---|
| 1       | 0    | 0    |  |
| 2       | 0    | 0    |  |
| 3       | 0    | 0    |  |
| 4       | 0    | 0    |  |

Figure 4-13

### 4.6.3 Log

Here is for you to view system log file. System lists the following information. See Figure 4-14. Log types include system operation, configuration operation, data management, alarm event, record operation, log clear and etc.

- Start time/end time: Pleased select start time and end time, then click search button. You can view the log files in a list. System max displays 100 logs in one page. It can max save 1024 log files. Please use page up/down button on the interface or click button ,  on the remote control to view more.
- Backup: Please select a folder you want to save; you can click the backup button to save the log files. After the backup, you can see there is a folder named Log\_time on the backup path. Double click the folder, you can see the log file
- Details: Click the Details button or double click the log item, you can view the detailed information. See Figure 4-15. Here you can use rolling bar to view information, or you can use Page up/Page down to view other log information.

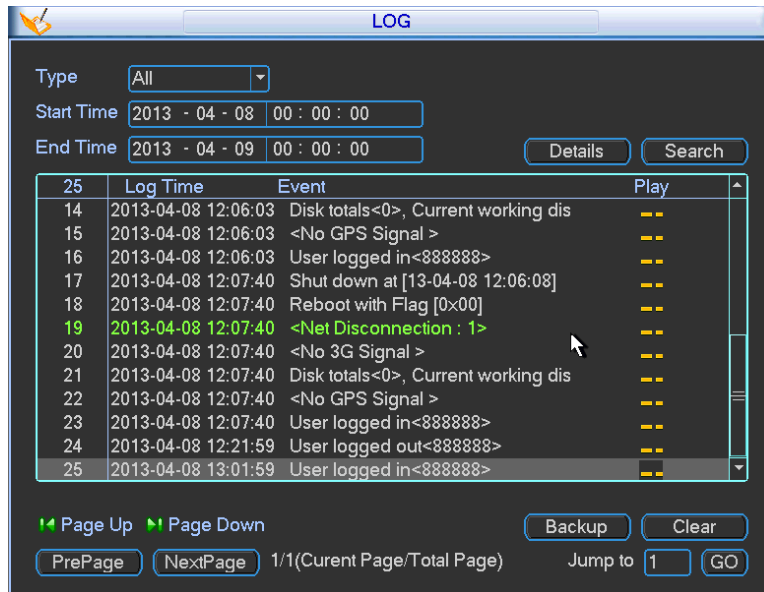

Figure 4-14

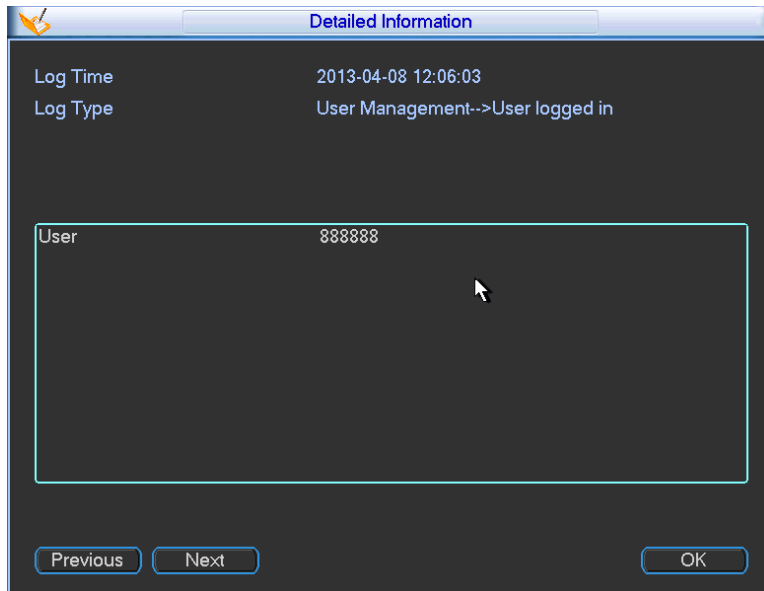

Figure 4-15

#### 4.6.4 Version

Here is for you to view some version information. See Figure 4-16.

- Channel
- Alarm in
- Alarm out
- System version:
- Build Date
- Web
- Serial number

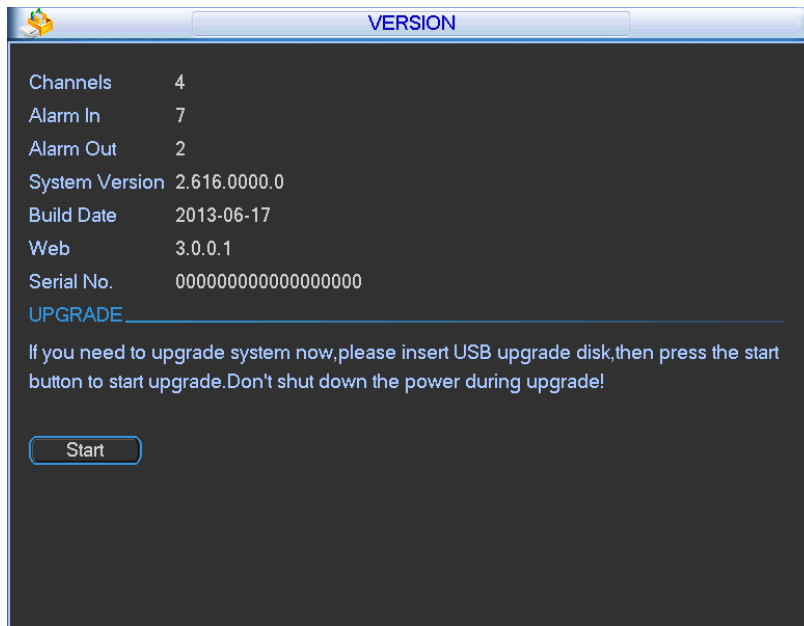

Figure 4-16

#### 4.6.5 Online Users

Here is for you manage online users connected to the local device. See Figure 4-17.

You can disconnect one user or block one user if you have proper system right. You can max block for 65535 seconds.

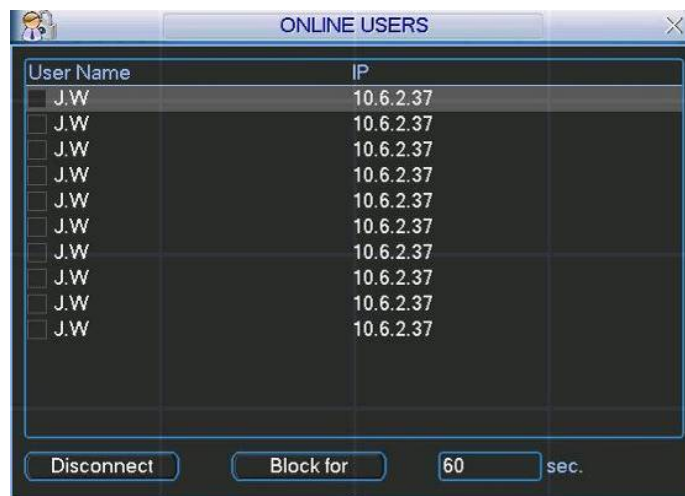

Figure 4-17

#### 4.6.6 Network Info

In this interface, you can see network test and network load information.

##### 4.6.6.1 Network Test

Network test interface is shown as in Figure 4-18.

Destination IP: Please input valid IPV4 address and domain name.

Test: Click it to test the connection with the destination IP address. The test results can display average delay and packet loss rate and you can also view the network status as OK, bad, no connection and etc.

Network Sniffer backup: Please insert USB2.0 device and click the Refresh button, you can view the device on the following column. You can use the dropdown list to select peripheral device.

Click Browse button to select the snap path. The steps here are same as preview backup operation.

You can view all connected network adapter names (including Ethernet, WIFI, and 3G), you can click the button  on the right panel to begin Sniffer. Click the grey stop button to stop. Please note system can not Sniffer several network adapters at the same time.

After Sniffer began, you can exit to implement corresponding network operation such as login WEB, monitor. Please go back to Sniffer interface to click  stop Sniffer. System can save the packets to the specified path. The file is named after "Network adapter name+time". You can use software such as Wireshark to open the packets on the PC for the professional engineer to solve complicated problems.

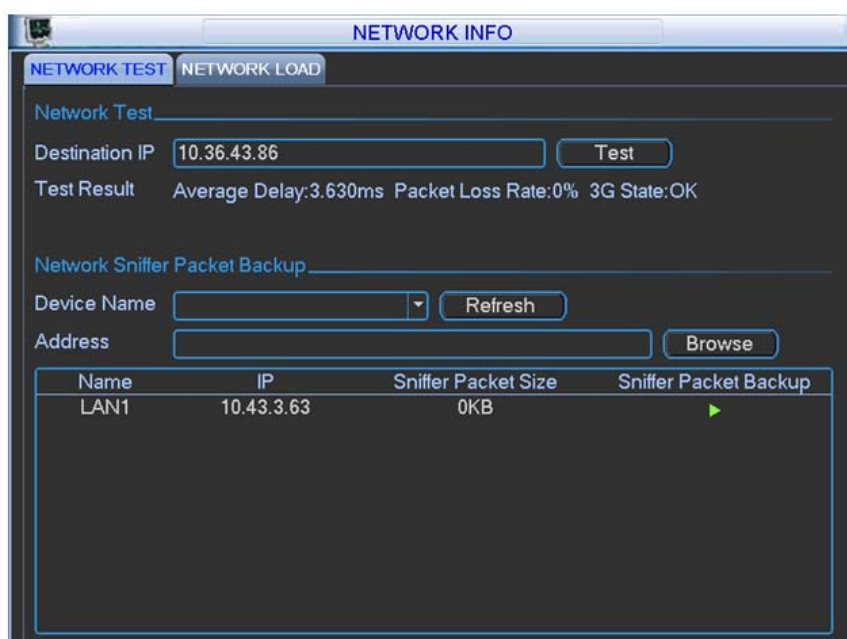

Figure 4-18

#### 4.6.6.2 Network Load

Network load is shown as in Figure 4-19. Here you can view the follow statistics of the device network adapter.

Here you can view information of all connected network adapters. The connection status is shown as offline if connection is disconnected. Click one network adapter, you can view the flow statistics such as send rate and receive rate at the top panel

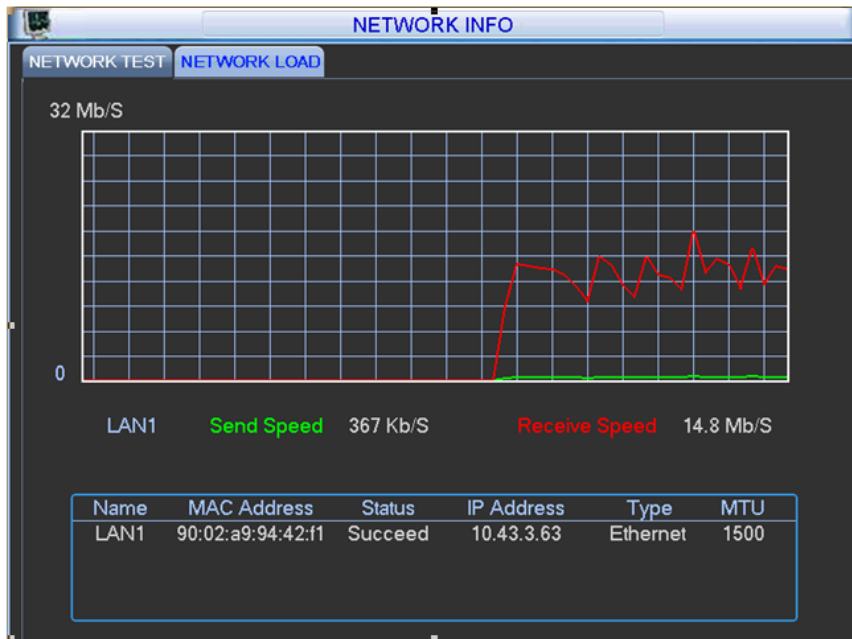

Figure 4-19

## 4.7 Setting

In main menu, highlight setting icon and double click mouse. System setting interface is shown as below. See Figure 4-20.

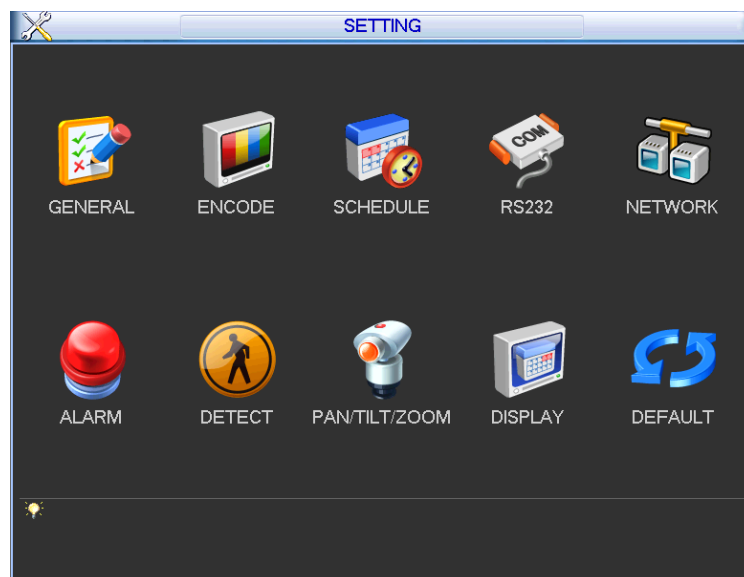

Figure 4-20

### Important

Please note you need to have the proper right to implement the following operation.

#### 4.7.1 General

General setting includes the following items. See Figure 4-21.

- System time: Here is for you to set system time
- Date format: There are three types: YYYY-MM-DD: MM-DD-YYYYY or DD-MM-YYYY.
- Date separator: There are three denotations to separate date: dot, beeline and solidus.

- DST: Here you can set DST time and date. Please enable DST function and then click set button. You can see an interface is shown as in Figure 4-22. Here you can set start time and end time by setting corresponding week setup. In Figure 4-22, enable date button, you can see an interface is shown as in Figure 4-23. Here you can set start time and end time by setting corresponding date setup.
- Time format: There are two types: 24-hour mode or 12-hour mode.
- Language: System supports various languages: Chinese (simplified), Chinese (Traditional), English, Italian, Japanese, French, Spanish (All languages listed here are optional. Slight difference maybe found in various series.)
- HDD full: Here is for you to select working mode when hard disk is full. There are two options: stop recording or rewrite. If current working HDD is overwritten or the current HDD is full while the next HDD is no empty, then system stops recording, If the current HDD is full and then next HDD is not empty, then system overwrites the previous files.
- Pack duration: Here is for you to specify record duration. The value ranges from 1 to 120 minutes. Default value is 60 minutes.
- Device No: When you are using one remote control (not included in the accessory bag) to control several DVRs, you can give a name to each DVR for your management.
- Video standard: There are two formats: NTSC and PAL.
- Realtime play: It is to set playback time you can view in the preview interface. The value ranges from 5 to 60 minutes.
- Device ID: Please input a corresponding device name here.
- Plate No: Here you can set vehicle plate number.
- Holiday setting: Click it you can see an interface shown as in Figure 4-24. Here you can set holiday date. Please go to the Holidays Period interface to set the holiday date record setup.
  - ✧ When you enable Holiday settings and schedule setup at the same time, holiday setting has the priority. If the selected day is a holiday, then system records as you set in holiday setting. If it is not a holiday, system records as you set in Schedule interface. Please note you need to go to chapter 4.7.3 Schedule to enable Holiday setup. Otherwise you can not enable holiday record setup.
  - ✧ Please note, there is no year setup on the holiday setting. For example, if you set 30th Oct, 2012 as a holiday, then the date of 30th Oct in each year will be set as a holiday. So, general speaking, your holiday setup in other year may also affect the holiday setup in 2012.
- Mouse property: Click mouse setup button, you can go to mouse setup interface. See Figure 4-25. You can set double click speed via dragging the slide bard. You can Click Default button to restore default setup.
- Startup wizard: Once you check the box here, system will go to the startup wizard directly when the system restarts the next time. Otherwise, it will go to the login interface.
- Auto logout: Here is for you to set auto logout interval once login user remains inactive for a specified time. Value ranges from 0 to 60 minutes.
- Navigation bar: Check the box here, system displays the navigation bar on the interface when you boot up device the next time. Otherwise, it goes to the system login interface directly. .

**Note:**

Since system time is very important, do not modify time casually unless there is a must!

Before your time modification, please stop record operation first!

After completing all the setups please click save button, system goes back to the previous menu.

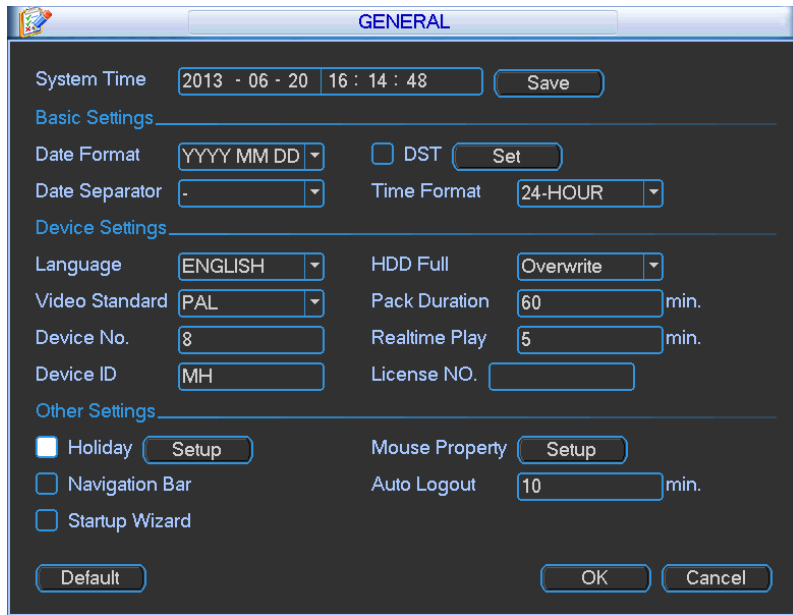

Figure 4-21

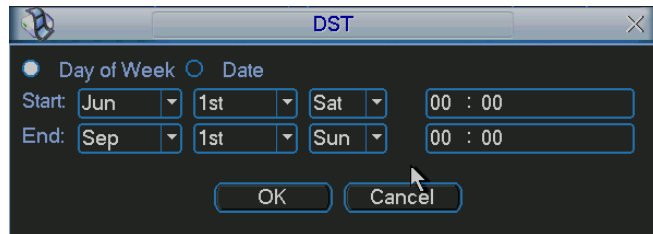

Figure 4-22



Figure 4-23

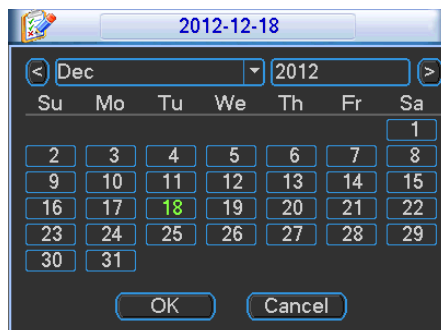

Figure 4-24

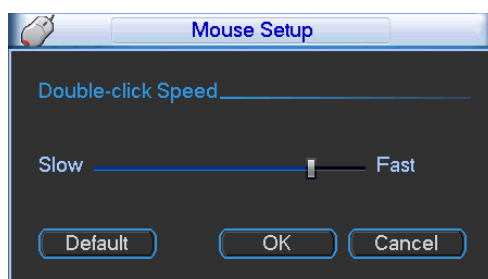

Figure 4-25

#### 4.7.2 Encode

Encode setting includes the following items. See Figure 4-26.

Please note some series do not support extra stream.

- Channel: Select the channel you want.
- Type: Please select from the dropdown list. There are three options: regular/motion detect/alarm. You can set the various encode parameters for different record types.
- Compression: System supports H.264, MPEG4, MJPEG and etc.
- Resolution: The mainstream resolution type. Generally there is D1/HD1/CIF/2CIF/QCIF and etc.
- Frame rate: It ranges from 1f/s to 25f/s in NTSC mode and 1f/s to 30f/s in PAL mode.
- Bit rate type: System supports two types: CBR and VBR. In VBR mode, you can set video quality.
- Quality: There are six levels ranging from 1 to 6. The sixth level has the highest image quality.
- Video/audio: You can enable or disable the video/audio. The main stream is enabled by default. The record includes audio and video if you highlight audio button here. For extra stream, you need to check video first and then select audio.
- Audio format: Here you can set device audio format.
- Overlay: Click overlay button, you can see an interface is shown in Figure 4-27. Please note the following overlay titles can not be in the same position. **Please note only the unit of GPS module supports GPS overlay function.**
  - ✧ Cover area (Privacy mask): Here is for you to set privacy mask section. You can drag you mouse to set proper section size. In one channel video, system max supports 4 zones in one channel.
  - ✧ Preview/monitor: privacy mask has two types. Preview and Monitor. Preview means the privacy mask zone can not be viewed by user when system is in preview status. Monitor means the privacy mask zone can not be view by the user when system is in monitor status.
  - ✧ Time display: You can select system displays time or not when you playback. Please click set button and then drag the title to the corresponding position in the screen.
  - ✧ Channel display: You can select system displays channel number or not when you playback. Please click set button and then drag the title to the corresponding position in the screen.
  - ✧ Plate No. : You can select system displays car number or not when you playback.
  - ✧ GPS display: You can select system displays latitude and longitude or not when you playback.

- Snapshot: Click snapshot button, you can set snapshot mode, picture size, quality and frequency. See Figure 4-28. **Before the snapshot operation, please make sure the front-end device supports current operation.**
- ✧ Snapshot mode: There are two modes: Timing (Schedule) and activation. If you set timing mode, you need to set snapshot frequency. If you set activation snapshot, you need to go to Detect interface (Main menu->Setting-Detect) to set snapshot activation operation.
- ✧ Image size: Here you can set snapshot picture size.
- ✧ Image quality: Here you can set snapshot quality. The value ranges from 1 to 6.
- ✧ Snapshot frequency: It is for you to set timing (schedule) snapshot interval. The value ranges from 1-7 picture(s) per second.
- Copy: After you complete the setup, you can click Copy button to copy current setup to other channel(s). You can see an interface is shown as in Figure 4-29. You can see current channel number is grey. Please check the number to select the channel or you can check the box ALL. Please click the OK button in Figure 4-29 and Figure 4-26 respectively to complete the setup.

Please highlight icon  to select the corresponding function.

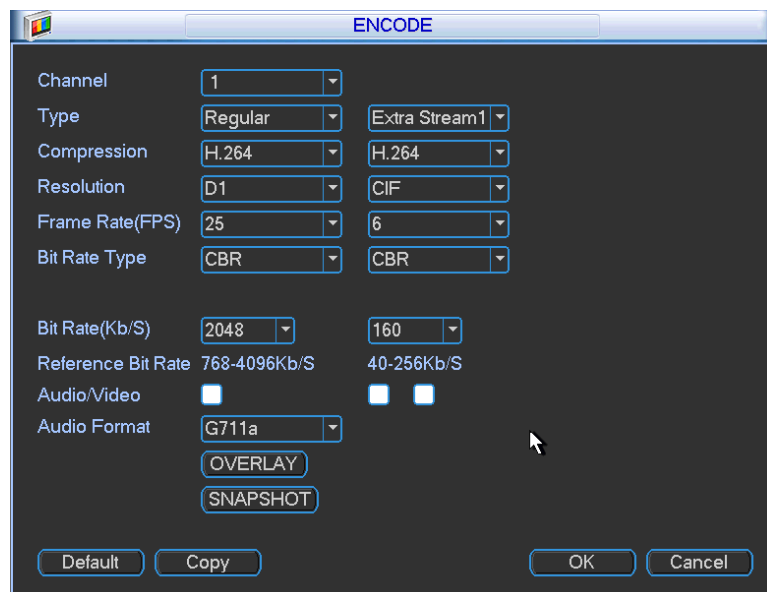

Figure 4-26

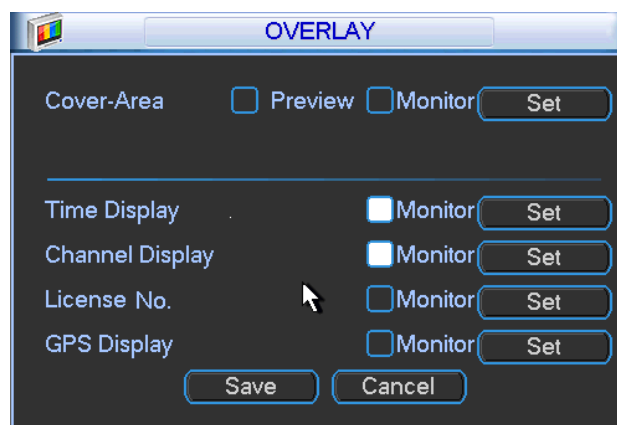

Figure 4-27

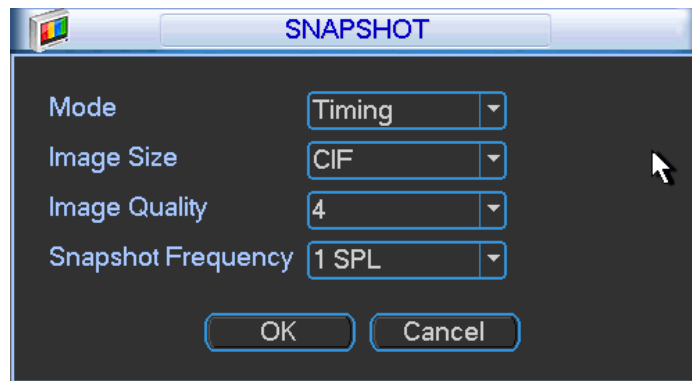

Figure 4-28

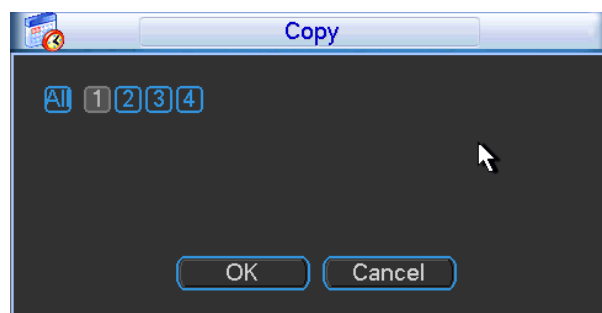



Figure 4-29

### 4.7.3 Schedule

In the main menu, from setting to schedule, you can go to schedule menu. See Figure 4-30.

- Channel: Please select the channel number first. You can select “all” if you want to set for the whole channels.
- Week day: There are eight options: ranges from Saturday to Sunday and all.
- Pre-record: System can pre-record the video before the event occurs into the file. The value ranges from 1 to 30 seconds depending on the bit stream.
- Redundancy: System supports redundancy backup function. It allows you backup recorded file in two disks. You can highlight Redundancy button to activate this function. Please note, before enable this function, please set at least one HDD as redundant. (Main menu->Advanced->HDD Management). **Please note this function is null if there is only one HDD.**
- Snapshot: You can enable this function to snapshot image when an alarm occurs.
- Record types: There are four types: regular, motion detection (MD), Alarm, MD & alarm.
- Holiday: Highlight the button here, the holiday settings in General interface (Chapter 4.7.1) becomes activated.

Please highlight icon  to select the corresponding function. After completing all the setups please click save button, system goes back to the previous menu.

At the bottom of the menu, there are color bars for your reference. Green color stands for regular recording, yellow color stands for motion detection and red color stands for alarm recording. The white means the MD and alarm record is valid. Once you have set to record

when the MD and alarm occurs, system will not record neither motion detect occurs nor the alarm occurs.

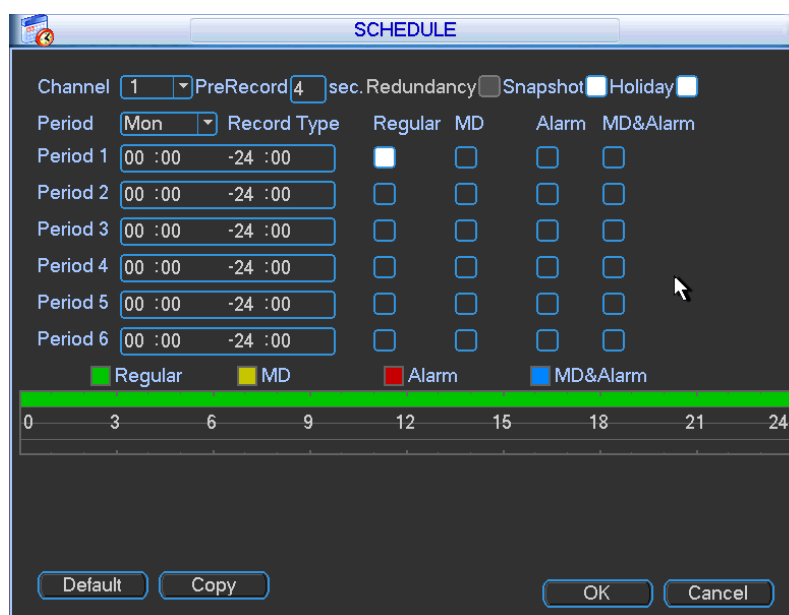

Figure 4-30

#### 4.7.4 RS232

RS232 interface is shown as below. There are five items. See Figure 4-31.

- Function: There are various devices for you to select. Console is for you to use the COM or mini-end software to upgrade or debug the program. The control keyboard is for you to control the device via the special keyboard. Transparent COM (adapter) is to connect to the PC to transfer data directly. Protocol COM is for card overlay function. Network keyboard is for you to use the special keyboard to control the device. PTZ matrix is to connect to the peripheral matrix control.
- Baud rate: You can select proper baud rate.
- Data bit: You can select proper data bit. The value ranges from 5 to 8.
- Stop bit: There are three values: 1/1.5/2.
- Parity: there are five choices: none/odd/even/space mark.

System default setup is:

- Function: Console
- Baud rate:115200
- Data bit:8
- Stop bit:1
- Parity: None

After completing all the setups please click save button, system goes back to the previous menu.

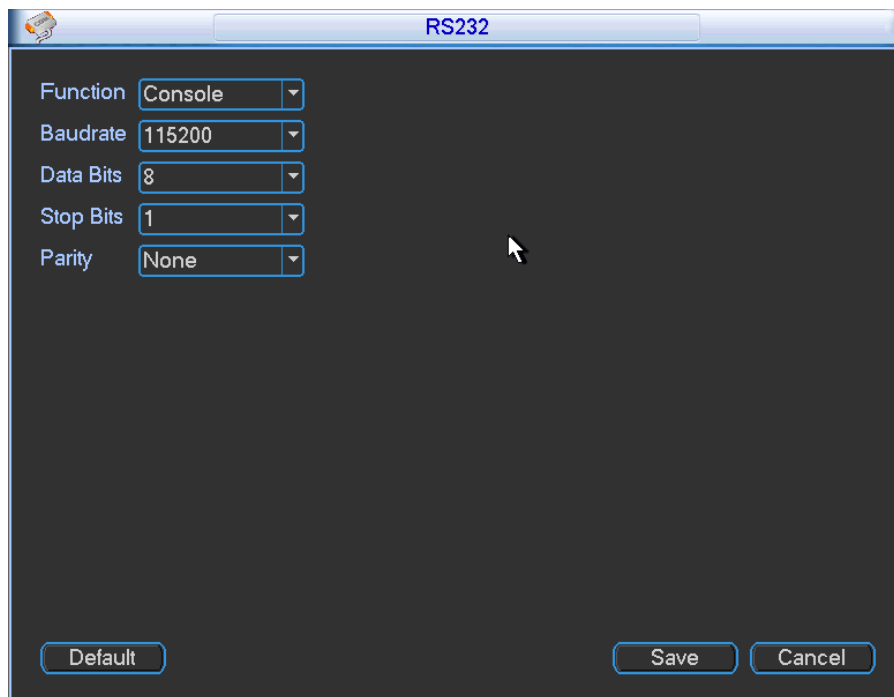

Figure 4-31

#### 4.7.5 Network

Here is for you to input network information. See Figure 4-32.

- IP Version: There are two options: IPv4 and IPv6. Right now, system supports these two IP address format and you can access via them.
- MAC address: The host in the LAN can get a unique MAC address. It is for you to access in the LAN. It is read-only.
- IP address: Here you can use up/down button (▲▼) or input the corresponding number to input IP address. Then you can set the corresponding subnet mask the default gateway.
- Subnet prefix: The input value ranges from 0 to 128. It is to mark a specified network MAC address. Usually it includes an organization of multiple-level.
- Default gateway: Here you can input the default gateway. **Please note system needs to check the validity of all IPv6 addresses. The IP address and the default gateway shall be in the same IP section. That is to say, the specified length of the subnet prefix shall have the same string.**
- DHCP: It is to auto search IP. When enable DHCP function, you can not modify IP/Subnet mask /Gateway. These values are from DHCP function. If you have not enabled DHCP function, IP/Subnet mask/Gateway display as zero. You need to disable DHCP function to view current IP information.
- TCP port: Default value is 37777. You can change if necessary.
- UDP port: Default value is 37778. You can change if necessary.
- HTTP port: Default value is 80.
- RTSP port: Default value is 554.

**Important: System needs to reboot after you changed and saved any setup of the above four ports. Please make sure the port values here do not conflict.**

- Max connection: system support maximal 20 users. 0 means there is no connection limit.
- Preferred DNS server: DNS server IP address.
- Alternate DNS server: DNS server alternate address.

- Transfer mode: Here you can select the priority between fluency/video qualities.
- LAN download: System can process the downloaded data first if you enable this function. The download speed is 1.5X or 2.0X of the normal speed.

**Important**

**For the IP address of IPv6 version, default gateway, preferred DNS and alternate DNS, the input value shall be 128-digit. It shall not be left in blank.**

After completing all the setups please click save button, system goes back to the previous menu.

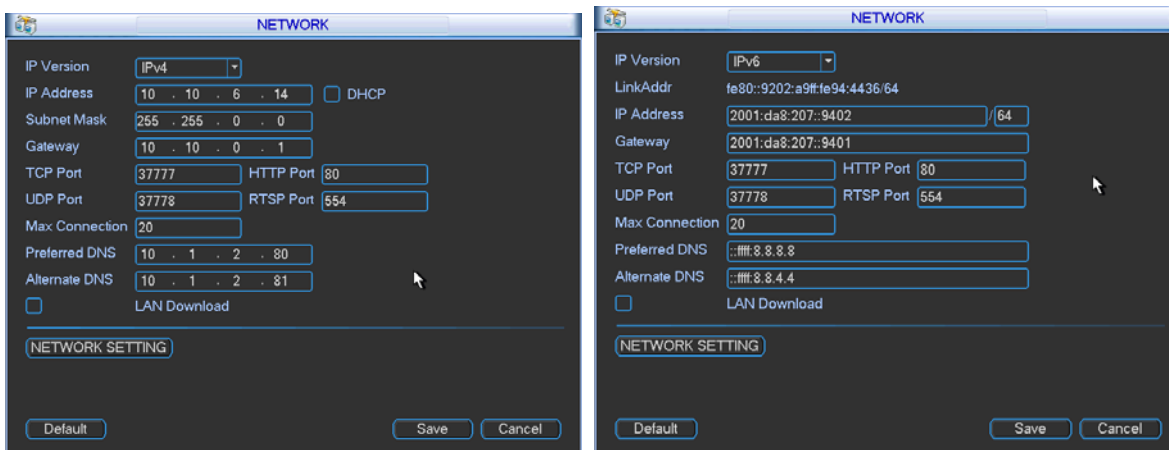

Figure 4-32

**4.7.5.1 Network Setting**

Network setting interface is shown as in Figure 4-33. Please check the box to enable corresponding function and then double click current item to go to setup interface.

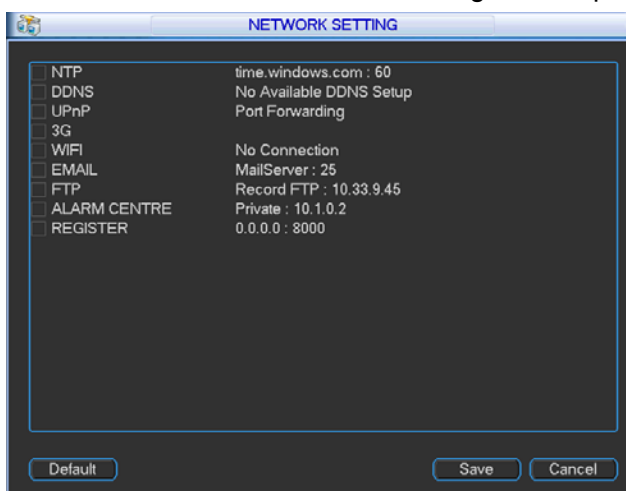

Figure 4-33

**4.7.5.2 NTP Setup**

You need to install SNTP server (Such as Absolute Time Server) in your PC first. In Windows XP OS, you can use command “net start w32time” to boot up NTP service.

NTP setup interface is shown as in Figure 4-34.

- Host IP: Input your PC address.
- Port: This series DVR supports TCP transmission only. Port default value is 123.
- Update interval: minimum value is 1. Max value is 65535. (Unit: minute)
- Time zone: select your corresponding time zone here.
- Update period: You can input interval here.

- Manual update: It allows you to synchronize the time with the server manually.

Here is a sheet for your time zone setup.

| City /Region Name           | Time Zone |
|-----------------------------|-----------|
| London                      | GMT+0     |
| Berlin                      | GMT+1     |
| Cairo                       | GMT+2     |
| Moscow                      | GMT+3     |
| New Deli                    | GMT+5     |
| Bangkok                     | GMT+7     |
| Beijing (Hong Kong)         | GMT+8     |
| Tokyo                       | GMT+9     |
| Sydney                      | GMT+10    |
| Hawaii                      | GMT-10    |
| Alaska                      | GMT-9     |
| Pacific Time(P.T)           | GMT-8     |
| American Mountain Time(M.T) | GMT-7     |
| American Central Time(C.T)  | GMT-6     |
| American Eastern Time(E.T)  | GMT-5     |
| Atlantic Time               | GMT-4     |
| Brazil                      | GMT-3     |
| Middle Atlantic Time        | GMT-2     |

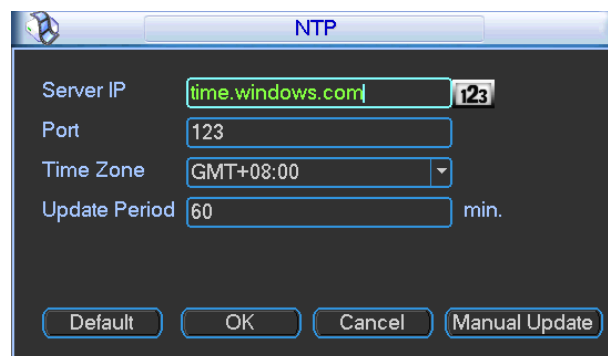

Figure 4-34

#### 4.7.5.3 DDNS

DDNS setup interface is shown as in Figure 4-35.

You need a PC of fixed IP in the internet and there is the DDNS software running in this PC. In other words, this PC is a DNS (domain name server).

In network DDNS, please select DDNS type and highlight enable item. Then please input your PPPoE name you get from you IPS and server IP (PC with DDNS) . Click save button and then reboot system.

Click save button, system prompts for rebooting to get all setup activated.

After rebooting, open IE and input the domain name.

Now you can open DDNSServer web search page.

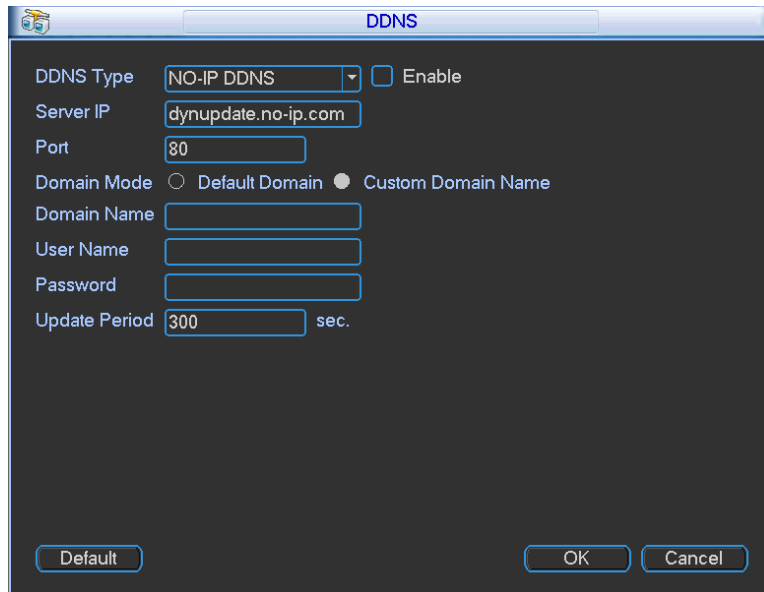

Figure 4-35

Please note NNDS type includes: CN99 DDNS, NO-IP DDNS, Quick DDNS, and Dyn dns DDNS. All the DDNS can be valid at the same time, you can select as you requirement. Quick DDNS function shall work with special DDNS server and special Professional Surveillance Software (PSS).

### Quick DDNS and Client-end Introduction

#### 1) Background Introduction

Device IP is not fixed if you use ADSL to login the network. The DDNS function allows you to access the DVR via the registered domain name. Besides the general DDNS, the quick DDNS works with the device from the manufacturer so that it can add the extension function.

#### 2) Function Introduction

The quick DDNS client has the same function as other DDNS client end. It realizes the bonding of the domain name and the IP address. Right now, current DDNS server is for our own devices only. You need to refresh the bonding relationship of the domain and the IP regularly. There is no user name, password or the ID registration on the server. At the same time, each device has a default domain name (Generated by MAC address) for your option. You can also use customized valid domain name (has not registered.).

#### 3) Operation

Before you use our quick DDNS, you need to enable this service and set proper server address, port value and domain name.

- Server address: [www.quickddns.com](http://www.quickddns.com)
- Port number: 80
- Domain name: There are two modes: Default domain name and customized domain name. Except default domain name registration, you can also use customized domain name (You can input your self-defined domain name.). After successful registration, you can use domain name to login installed of the device IP.
- User name: It is optional. You can input your commonly used email address.

#### Important

- Do not register frequently. The interval between two registrations shall be more than 60 seconds. Too many registration requests may result in server attack.
- System may take back the domain name that is idle for one year. You can get a notification email before the cancel operation if your email address setup is OK.

#### 4.7.5.4 UPNP

The UPNP protocol is to establish a mapping relationship between the LAN and the WAN. Please input the router IP address in the LAN in Figure 4-32. Double click the UPNP item in Figure 4-32, you can see the following interface. See Figure 4-36.

- UPNP on/off : Turn on or off the UPNP function of the device.
- Status: When the UPNP is offline, it shows as “Unknown”. When the UPNP works it shows “Success”
- Router LAN IP: It is the router IP in the LAN.
- WAN IP: It is the router IP in the WAN.
- Port Mapping list: The port mapping list here is the one to one relationship with the router’s port mapping setting.
- Enable Switch  : : It shows that the function of port mapping is enabled in this port.
- List:
  - ◇ Service name: Defined by user.
  - ◇ Protocol: Protocol type
  - ◇ Internal port: Port that has been mapped in the router.
  - ◇ External port: Port that has been mapped locally.
- Default: UPNP default port setting is the HTTP, TCP and UDP of the DVR.
- Add to the list: Click it to add the mapping relationship.
- Delete: Click it to remove one mapping item.

Double click one item; you can change the corresponding mapping information. See Figure 4-37.

#### **Important:**

**When you are setting the router external port, please use 1024~5000 port. Do not use well-known port 1~255 and the system port 256~1023 to avoid conflict.**

**For the TCP and UDP, please make sure the internal port and external port are the same to guarantee the proper data transmission.**

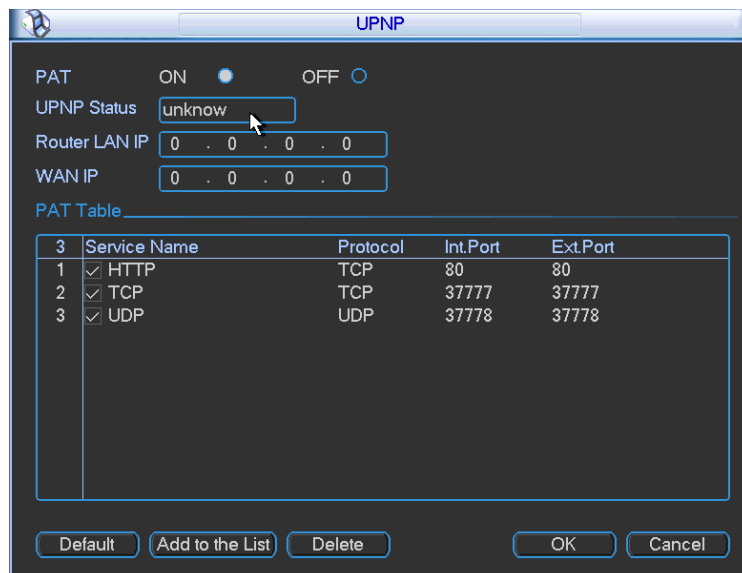

Figure 4-36



Figure 4-37

#### 4.7.5.5 3G Setting

3G setup interface is shown as below. See Figure 4-38. It is to display current wireless network signal intensity such as EVDO, CDMA1x, WCDMA, WCDMA, EDGE and etc.

- 3G module: It is to display current wireless network adapter name.
- 3G Enable/Disable: Check the box here to enable 3G module.
- Network type: There are various network types for different 3G network modules. You can select according to your requirements.
- APN: It is the wireless connection server. It is to set you access the wireless network via which method.
- AUTH: It is the authentication mode. It supports PAP/CHAP.
- Dial number: Please input 3G network dialup number you got from your ISP.
- User name: It is the user name for you to login the 3G network.
- Password: It is the password for you to login the 3G network.
- Pulse interval: You can set dialup duration. Once you disable the extra stream, the connection time begins. For example, if you input 5 seconds here, then 3G network connection period is 5 seconds. The device automatically disconnect when time is up. If there is no extra stream, 3G network connection is valid all the time. **If the alive time is 0, then the 3G network connection is valid all the time.**

- Dial: Here you can enable or disable 3G network connection/disconnection manually.
- 3G wireless network: Here is to display wireless network status, SIM card status, dial status. If the 3G connection is OK, then you can see the device IP address the wireless network automatically allocates.
- 3G flow control: It is to show the 3G flow you used. See Figure 4-39.

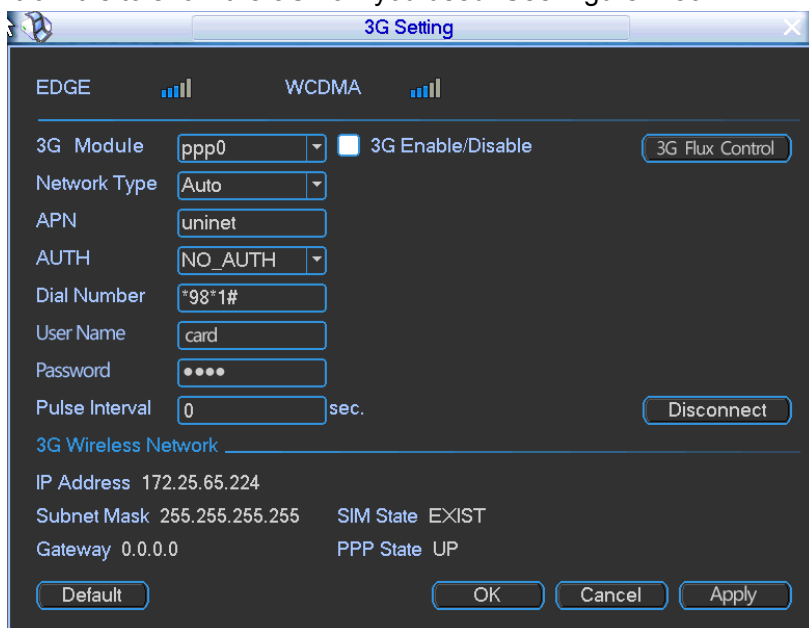

Figure 4-38

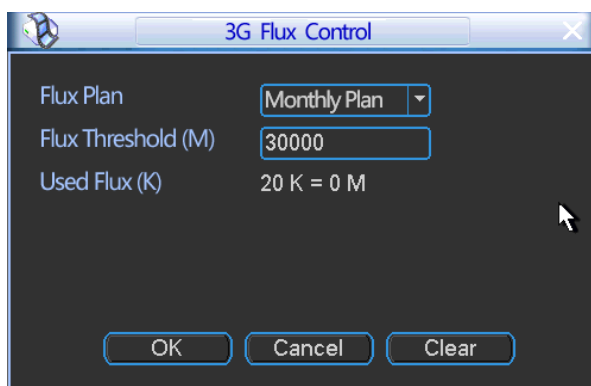

Figure 4-39

#### 4.7.5.6 WIFI

You can view the WIFI connection status in the Network Setting interface. See Figure 4-40. You can view current connection status and IP address if there is a connection.

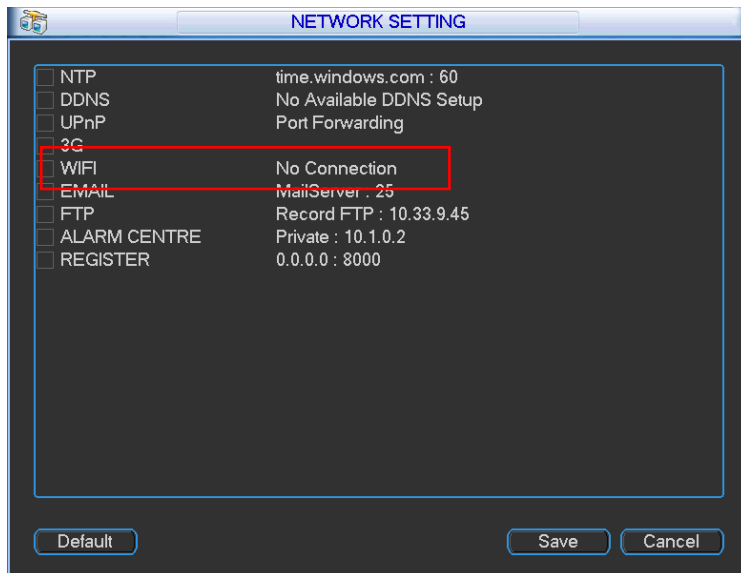

Figure 4-40

The WIFI interface is shown as below. See Figure 4-41.

- Auto connect WIFI: Check the box here, system automatically connects to the WIFI hotspot one after another according to the priority until it connects to one hotspot.
- Refresh: You can click it to search the hotspot list again. It can automatically add the information such as the password if you have set it before.
- Disconnect: Here you can click it to turn off the connection.
- Connect: Here you can click it to connect to the hotspot.
- WIFI working status: Here you can view current connection status.
- Static Setting: Click it; you can go to the static setup interface. See Figure 4-42.

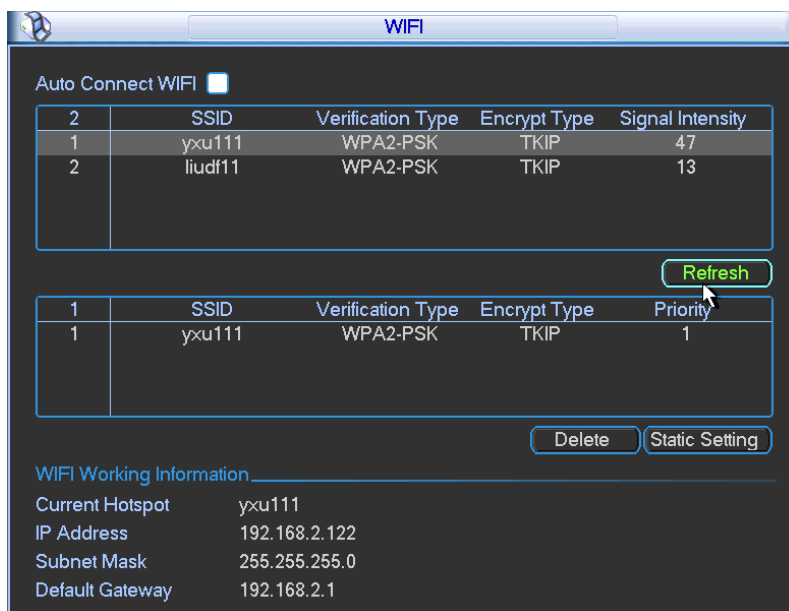

Figure 4-41



Figure 4-42

Please note:

- After successful connection, you can see WIFI connection icon at the top right corner of the preview interface.
- When the hotspot verification type is WEP, system displays as AUTO since the device can not detect its encryption type.
- System does not support verification type WPA and WPA2. The display may become abnormal for the verification type and encryption type.

#### 4.7.5.7 Email

The email interface is shown as below. See Figure 4-43.

- SMTP server: Please input your email SMTP server IP here.
- Port: Please input corresponding port value here.
- User name: Please input the user name to login the sender email box.
- Password: Please input the corresponding password here.
- Sender: Please input sender email box here.
- Title: Please input email subject here. System support English character and Arabic number. Max 32-digit.
- Receiver: Please input receiver email address here. System max supports 3 email boxes.
- SSL enable: System supports SSL encryption box.
- Interval: The send interval ranges from 0 to 3600 seconds. 0 means there is no interval.
- Health email enable: Please check the box here to enable this function. This function allows the system to send out the test email to check the connection is OK or not.
- Interval: Please check the above box to enable this function and then set the corresponding interval. System can send out the email regularly as you set here. Click the Test button, you can see the corresponding dialogue box to see the email connection is OK or not. See Figure 4-44.

Please note system will not send out the email immediately when the alarm occurs. When the alarm, motion detection or the abnormality event activates the email, system sends out the email according to the interval you specified here. This function is very useful when there are too many emails activated by the abnormality events, which may result in heavy load for the email server.

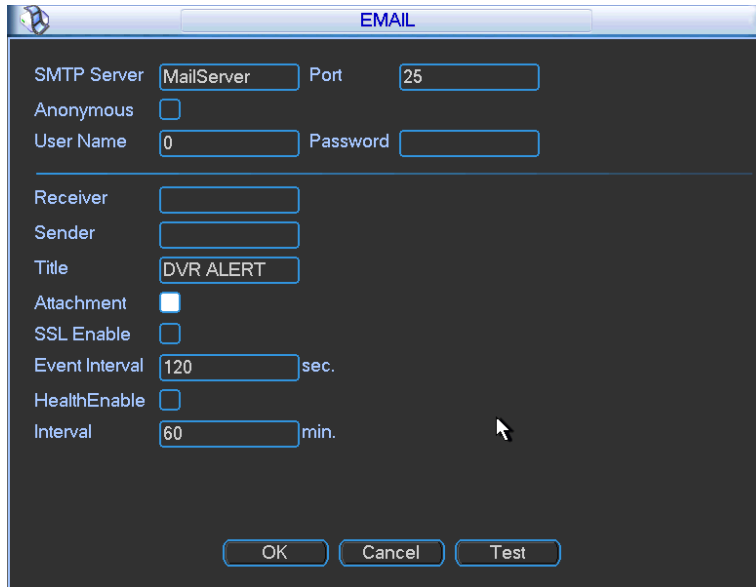

Figure 4-43

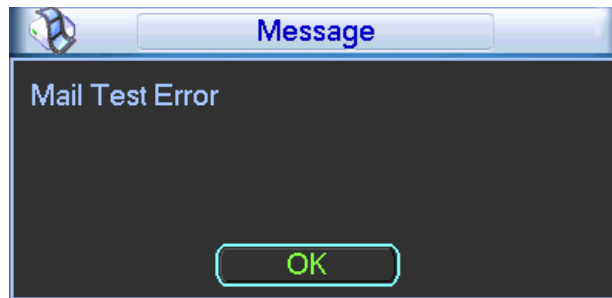

Figure 4-44

#### 4.7.5.8 FTP

You need to download or buy FTP service tool (such as Ser-U FTP SERVER) to establish FTP service.

Please install Ser-U FTP SERVER first. From “start” -> “program” -> Serv-U FTP Server -> Serv-U Administrator. Now you can set user password and FTP folder. Please note you need to grant write right to FTP upload user. See Figure 4-45.

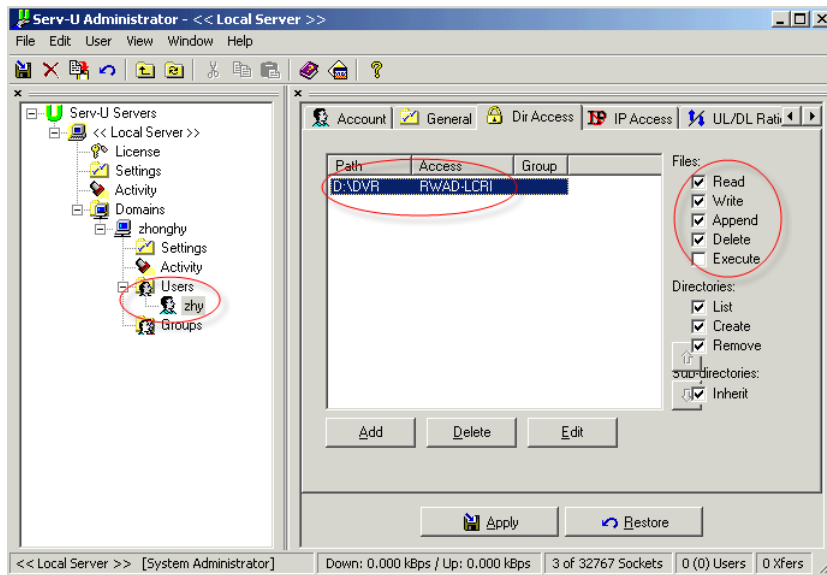

Figure 4-45

You can use a PC or FTP login tool to test setup is right or not.

For example, you can login user ZHY to [FTP://10.10.7.7](ftp://10.10.7.7) and then test it can modify or delete folder or not. See Figure 4-46.

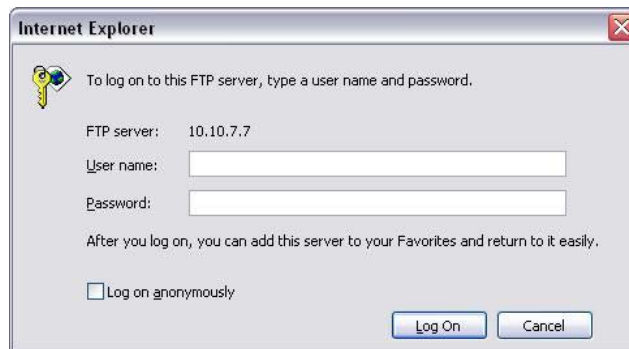

Figure 4-46

System also supports upload multiple DVRs to one FTP server. You can create multiple folders under this FTP.

In Figure 4-32, select FTP and then double click mouse. You can see the following interface. See Figure 4-47.

Please highlight the icon  in front of Enable to activate FTP function.

Here you can input FTP server address, port and remote directory. When remote directory is null, system automatically create folders according to the IP, time and channel.

User name and password is the account information for you to login the FTP.

File length is upload file length. When setup is larger than the actual file length, system will upload the whole file. When setup here is smaller than the actual file length, system only uploads the set length and auto ignore the left section. When interval value is 0, system uploads all corresponding files.

After completed channel and weekday setup, you can set two periods for one each channel.

Click the Test button, you can see the corresponding dialogue box to see the FTP connection is OK or not. See Figure 4-48.

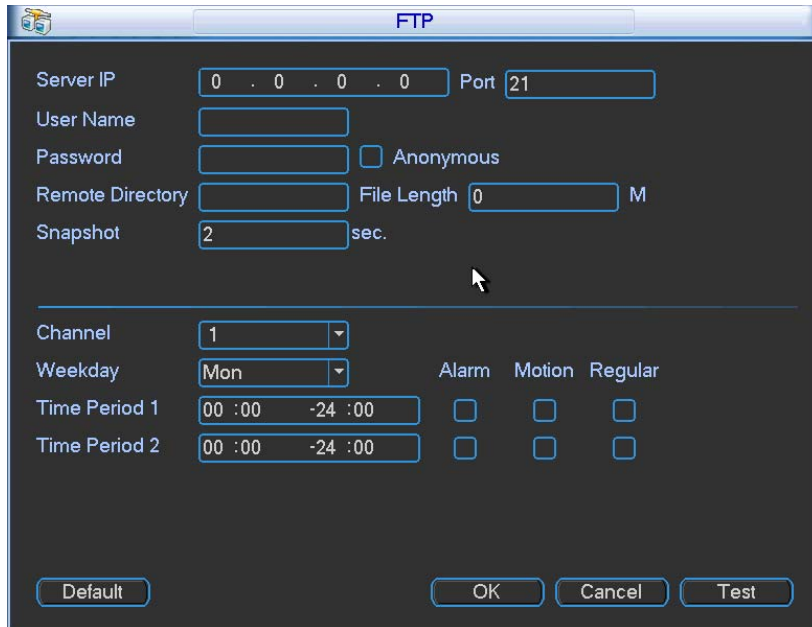

Figure 4-47

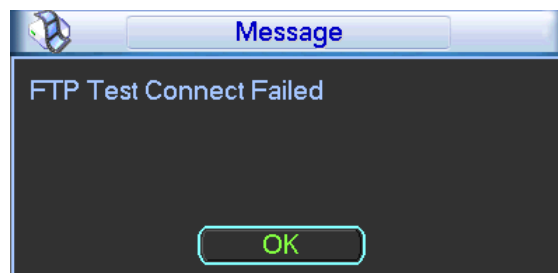

Figure 4-48

#### 4.7.5.9 Alarm center

Interface is pre-reserved for the users to develop this function. See Figure 4-49.

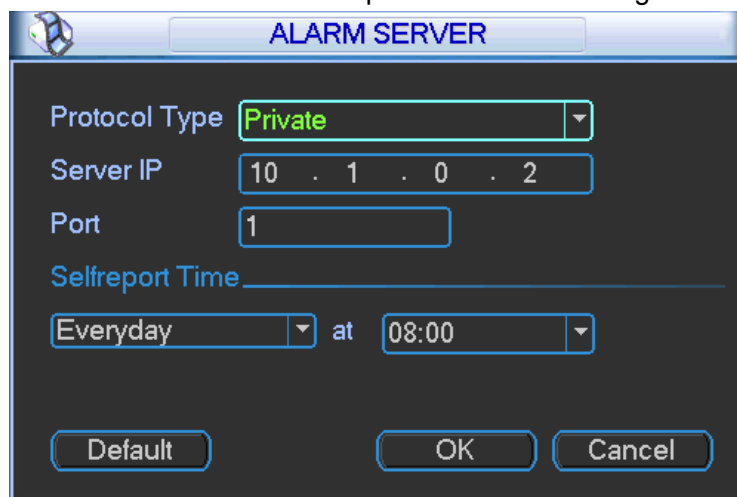

Figure 4-49

#### 4.7.5.10 Auto register

This function allows the device to auto register to the proxy you specified. In this way, you can use

the client-end to access the DVR and etc via the proxy. Here the proxy has a switch function. In the network service, device supports the server address of IPv4 or domain.

Please follow the steps listed below to use this function.

Please set proxy server address, port, and sub-device name at the device-end. Please enable the auto register function, the device can auto register to the proxy server.

1) The setup interface is shown as in Figure 4-50.

### Important

Do not input network default port such as TCP port number.

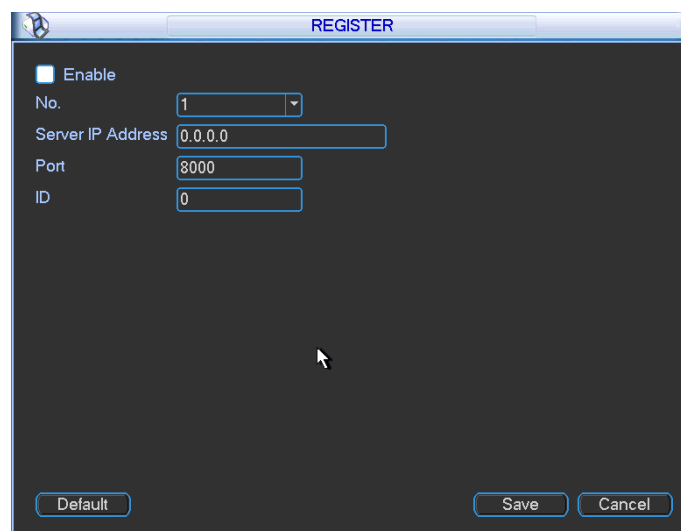

Figure 4-50

2) The proxy server software developed from the SDK. Please open the software and input the global setup. Please make sure the auto connection port here is the same as the port you set in the previous step.

3) Now you can add device. Please do not input default port number such as the TCP port in the mapping port number. The device ID here shall be the same with the ID you input in Figure 4-50. Click Add button to complete the setup.

4) Now you can boot up the proxy server. When you see the network status is Y, it means your registration is OK. You can view the proxy server when the device is online.

### Important

The server IP address can also be domain. But you need to register a domain name before you run proxy device server.

## 4.7.6 Alarm

In the main menu, from Setting to Alarm, you can see alarm setup interface. See Figure 4-51.

- Alarm in: Here is for you to select channel number.
- Event type: There are four types. Local input/network input.
  - ✧ Local input alarm: The alarm signal system detects from the alarm input port.
  - ✧ Network input alarm: It is the alarm signal from the network.
- Enable: Please you need to highlight this button to enable current function.
- Type: normal open or normal close.
- Trigger: Here is for you to set activation mode. There are two options: High/low.
- Alarm name: You can input customized name here.

- Overlay: Please highlight the box here to enable this function. It can overlay alarm information on the video screen when an alarm occurred.
- Period: It is to set local alarm period. System only enables local alarm in the specified period. Click the Set button; you can select the business day and the non-business day. Please note for the work day/free day setup and the specific work day setup, system just saves the latest setup. For example, the work day ranges from 8:30-17:30 Monday to Friday, and then you set the period 7:10-18:00 for Monday. So, the arm period of the Monday ranges from 7:10 to 18:00. Please highlight the corresponding button to enable this function.
- PTZ activation: When an alarm occurred, system can activate the PTZ operation such as preset x.
- Anti-dither: Here you can set anti-dither time. The value ranges from 5 to 600s. The anti-dither time refers to the alarm signal lasts time. It can be seem as the alarm signal activation stays such as the buzzer, tour, PTZ activation, snapshot, channel record. The stay time here does not include the latch time. During the alarm process, the alarm signal can begin an anti-dither time if system detects the local alarm again. The screen prompt, alarm upload, email and etc will not be activated. For example, if you set the anti-dither time as 10 second, you can see the each activation may last 10s if the local alarm is activated. During the process, if system detects another local alarm signal at the fifth second, the buzzer, tour, PTZ activation, snapshot, record channel will begin another 10s while the screen prompt, alarm upload, email will not be activated again. After 10s, if system detects another alarm signal, it can generate an alarm since the anti-dither time is out.
- Alarm output: The number here is the device alarm output port. You can select the corresponding ports(s) so that system can activate the corresponding alarm device(s) when an alarm occurred.
- Latch: When the anti-dither time ended, the channel alarm you select in the alarm output may last the specified period. The value ranges from 1 to 300 seconds. This function is not for other alarm activation operations. The latch is still valid even you disable the alarm event function directly.
- Show message: System can pop up a message to alarm you in the local host screen if you enabled this function.
- Alarm upload: System can upload the alarm signal to the network (including alarm centre and the WEB) if you enabled current function. System only uploads the alarm channel status. You can go to the WEB and then go to the Alarm interface to set alarm event and alarm operation. Please go to the Network interface to set alarm centre information.
- Send email: System can send out the alarm signal via the email to alert you when alarm occurs. Once you enable the snap function, system can also send out an image as the attachment. Please go to the Main Menu->Setting ->Network->Email interface to set.
- Record channel: you can select proper channel to record alarm video (Multiple choices).
  - ✧ You need to set alarm record mode as Schedule in Record interface (Main Menu->Advanced->Record). Please note the manual record has the highest priority. System record all the time no matter there is an alarm or not if you select Manual mode.
  - ✧ Now you can go to the Schedule interface (Main Menu->Setting->Schedule) to set the record type, corresponding channel number, week and date. You can select the record type:Regular/MD/Alarm/MD&Alarm. Please note, you can not select the MD&Alarm and MD(or Alarm) at the same time.

- ✧ Now you can go to the Encode interface to select the alarm record and set the encode parameter (Main Menu->Setting->Encode).
- ✧ Finally, you can set the alarm input as the local alarm and then select the record channel. The select channel begins alarm record when an alarm occurred. Please note system begins the alarm record instead of the MD record if the local alarm and MD event occurred at the same time.
- Tour: Here you can enable tour function when an alarm occurs. System supports 1/8-window tour. Please go to chapter 4.7.9 Display for tour interval setup. Please note the tour setup here has higher priority than the tour setup you set in the Display interface. Once there two tours are both enabled, system can enable the alarm tour as you set here when an alarm occurred. If there is no alarm, system implements the tour setup in the Display interface.
- Snapshot: You can enable this function to snapshot image when an alarm occurs.
- Buzzer: Highlight the icon to enable this function. The buzzer beeps when an alarm occurs.

Please highlight icon  to select the corresponding function. After setting all the setups please click save button, system goes back to the previous menu.

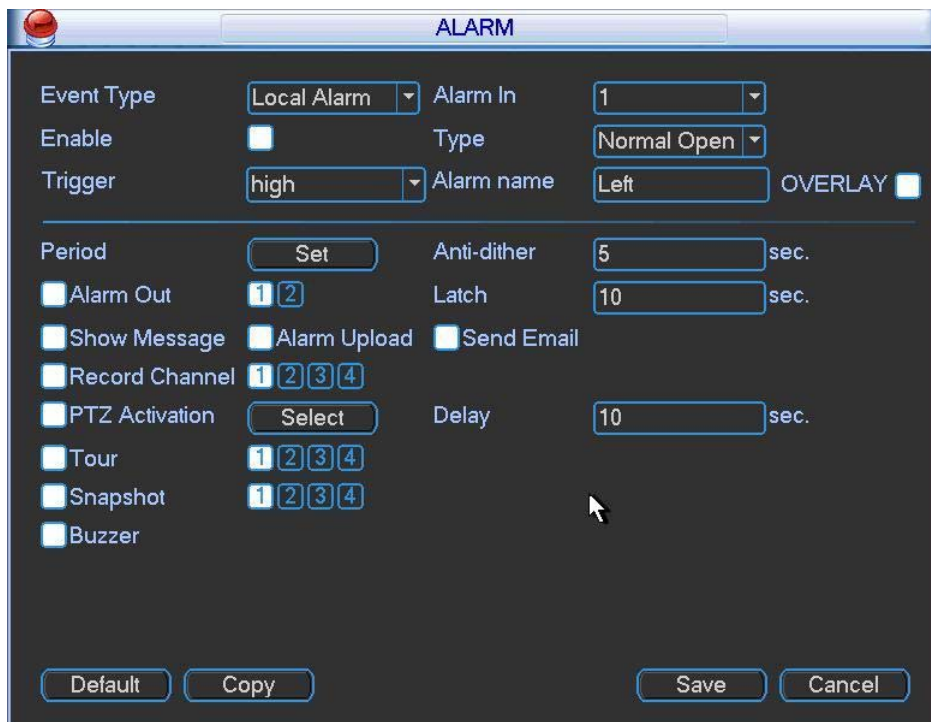

Figure 4-51

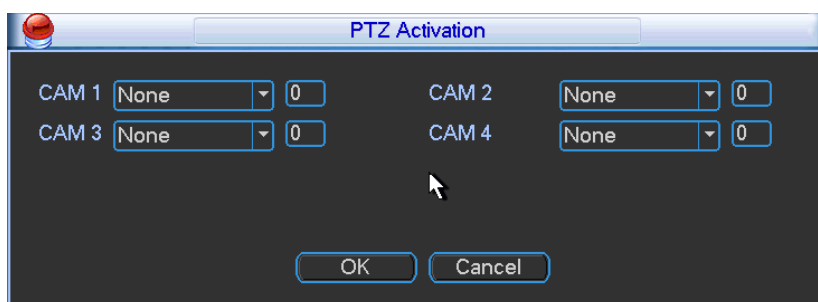

Figure 4-52

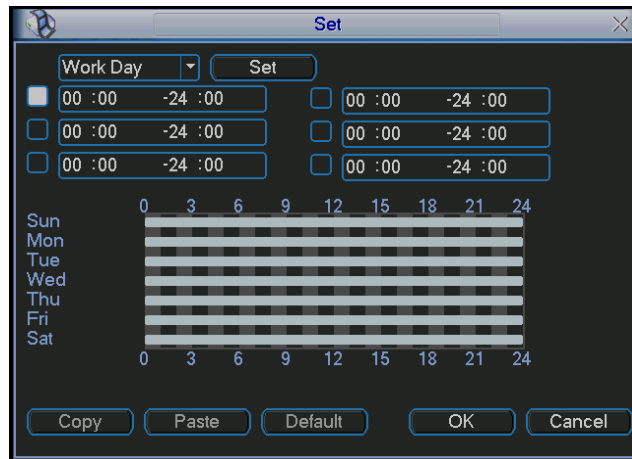

Figure 4-53

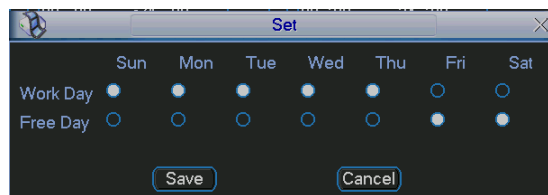

Figure 4-54

## 4.7.7 Detect

### Go to Detect Menu

In the main menu, from Setting to Detect, you can see motion detect interface. See Figure 4-55. There are three detection types: motion detection, video loss, camera masking.

- The video loss has no detection region and sensitivity setup and camera masking has no detection region setup.
- You can see motion detect icon if current channel has enabled motion detect alarm.
- You can drag your mouse to set motion detect region without AUX button. Please click OK button to save current region setup. Right click mouse to exit current interface.

#### 4.7.7.1 Motion Detect

Detection menu is shown as below. See Figure 4-55.

- Event type: From the dropdown list you can select motion detection type.
- Channel: Select a channel from the dropdown list to set motion detect function.
- Enable: Check the box here to enable motion detect function.
- Region: Click select button, the interface is shown as in Figure 4-56. Here you can set motion detection zone. There are 396(PAL)/330(NTSC) small zones. The green zone is current cursor position. Grey zone is the motion detection zone. Black zone is the disarmed zone. You can click AUX button to switch between the arm mode and disarm mode. In arm mode, you can click the direction buttons to move the green rectangle to set the motion detection zone. After you completed the setup, please click ENTER button to exit current setup. Do remember click save button to save current setup. If you click ESC button to exit the region setup interface system will not save your zone setup.
- Sensitivity: System supports 6 levels. The sixth level has the highest sensitivity.

- Period: Click set button, you can see an interface is shown as in Figure 4-58. Here you can set for business day and non-business day. In Figure 4-58 click set button, you can see an interface is shown as in Figure 4-59. Here you can set your own setup for business day and non-business day.
- Alarm output: when an alarm occurs, system enables peripheral alarm devices.
- Latch: when motion detection complete, system auto delays detecting for a specified time. The value ranges from 1-300(Unit: second)
- Show message: System can pop up a message to alarm you in the local host screen if you enabled this function.
- Alarm upload: System can upload the alarm signal to the network (including alarm centre) if you enabled current function.
- Send email: System can send out email to alert you when an alarm occurs.
- Record channel: Select the channel to activate recording function once an alarm occurred. Please make sure you have set MD record in encode interface(Main Menu->Setting->Schedule) and schedule record in manual record interface(Main Menu->Advanced->Manual Record)
- PTZ activation: Here you can set PTZ movement when an alarm occurs. System can go to a preset, when there is an alarm. Click “select” button, you can see an interface is shown as in Figure 4-57.
- Record Delay: System can delay the record for specified time after alarm ended. The value ranges from 10s to 300s.
- Tour: Here you can enable tour function when an alarm occurs. System one-window tour. Please go to chapter 4.7.9 Display for tour interval setup.
- Snapshot: You can enable this function to snapshot image when motion detect alarm occurs.
- Buzzer: Highlight the icon to enable this function. The buzzer beeps when an alarm occurs.

Please highlight icon  to select the corresponding function. After all the setups please click save button, system goes back to the previous menu.

**Note:**

In motion detection mode, you can not use copy/paste to set channel setup since the video in each channel may not be the same.

In Figure 4-56, you can left click mouse and then drag it to set a region for motion detection. Click Fn to switch between arm/withdraw motion detection. After setting, click enter button to exit.

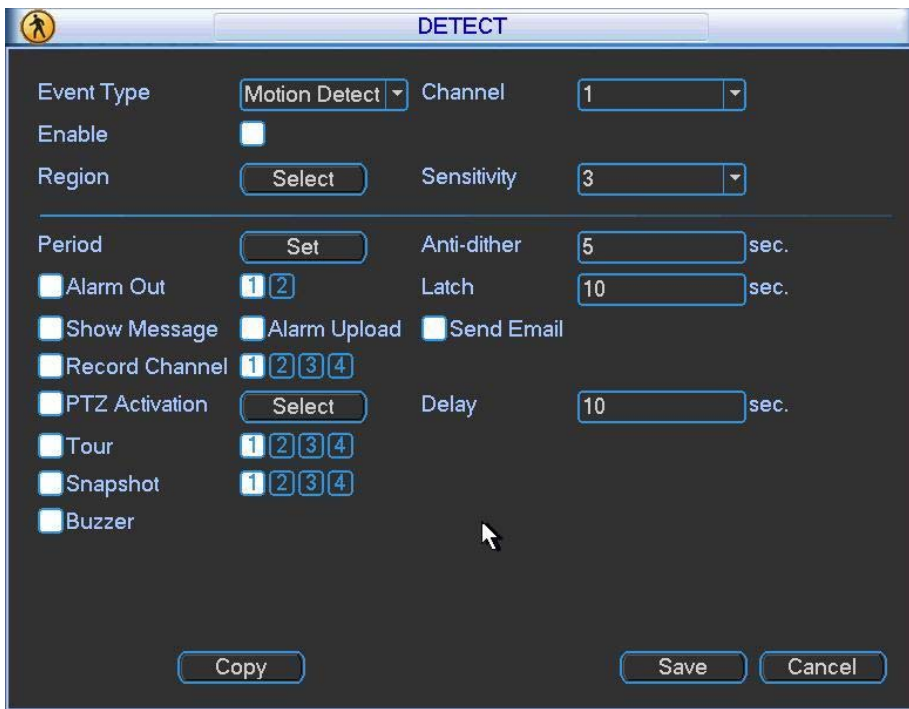

Figure 4-55

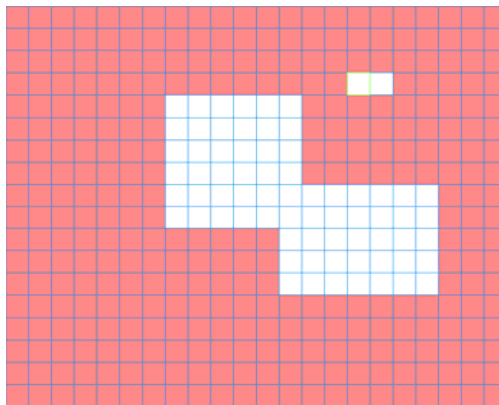

Figure 4-56

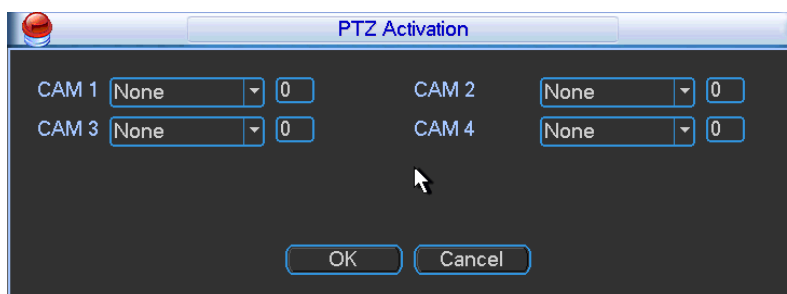

Figure 4-57

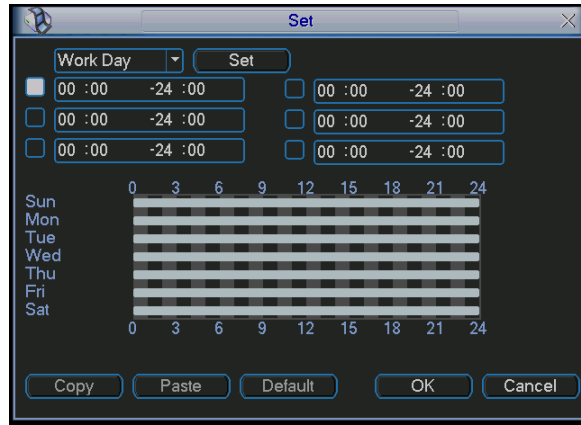

Figure 4-58

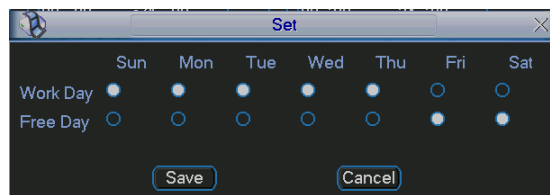

Figure 4-59

#### 4.7.7.2 Video Loss

In Figure 4-55, select video loss from the type list. You can see the interface is shown as in Figure 4-60. This function allows you to be informed when video loss phenomenon occurred. You can enable alarm output channel and then enable show message function. You can refer to chapter 4.7.7.1 Motion detect for detailed information.

**Tips:**

You can enable preset/tour/pattern activation operation when video loss occurs.

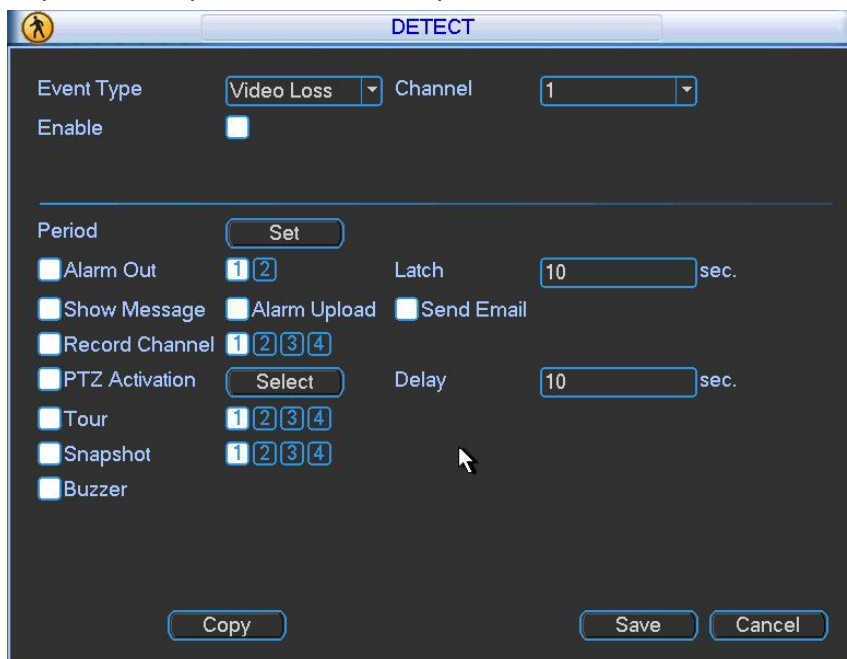

Figure 4-60

### 4.7.7.3 Camera Masking

When someone viciously masks the lens, or the output video is in one-color due to the environments light change, the system can alert you to guarantee video continuity. Camera masking interface is shown as in Figure 4-61. You can enable alarm output channel and then enable show message function. You can refer to chapter 4.7.7.1 Motion detect for detailed information.

#### Tips:

You can enable preset/tour/pattern activation operation when video loss occurs.

#### Note:

In Detect interface, copy/paste function is only valid for the same type, which means you can not copy a channel setup in video loss mode to camera masking mode.

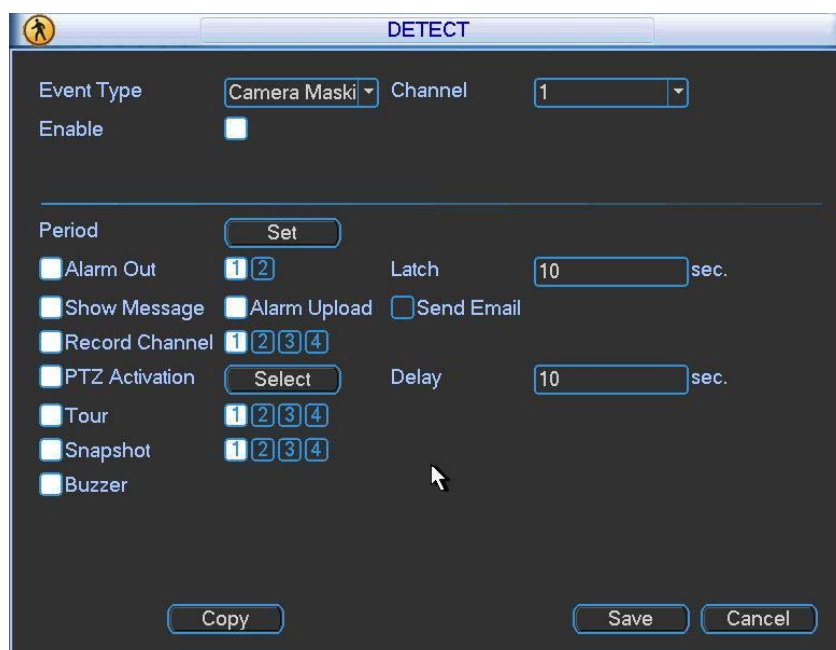

Figure 4-61

## 4.7.8 PTZ

**Note:** All the operations here are based on PELCOD protocol. For other protocols, there might be a little difference.

### Cable Connection

Please follow the procedures below to go on cable connection

- Connect the dome RS485 port to DVR 485 port.
- Connect dome video output cable to DVR video input port.
- Connect power adapter to the dome.

### PTZ Setup

**Note:** The camera video should be in the current screen. Before setup, please check the following connections are right:

- PTZ and decoder connection is right. Decoder address setup is right.
- Decoder A (B) line connects with DVR A (B) line.

Boot up the DVR, input user name and password.

In the main menu, click setting, and then click Pan/Tilt Control button. The interface is shown

as in Figure 4-62. Here you can set the following items:

- Channel: Select the current camera channel.
- PTZ type: There are two types: local/remote.
- Protocol: Select corresponding PTZ protocol(such as PELCOD)
- Address: Default address is 1.
- Baud rate: Select corresponding baud rate. Default value is 9600.
- Data bit: Select corresponding data bits. Default value is 8.
- Stop bit: Select corresponding stop bits. Default value is 1.
- Parity: There are three options: odd/even/none. Default setup is none.

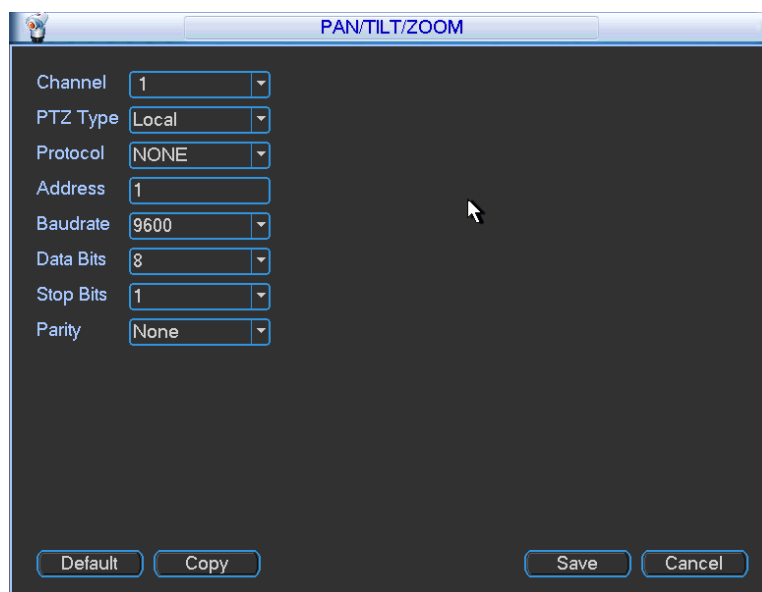

Figure 4-62

After completing all the setting please click save button.

In one window display mode, right click mouse (click “AUX” Button or right click mouse and then select Pan/Tilt/Zoom.).

Click Pan/Tilt/Zoom, the interface is shown as below. See Figure 4-63.

Here you can set the following items:

- Step: value ranges from 1 to 8.
- Zoom
- Focus
- Iris

Please click icon  and  to adjust zoom, focus and iris.



Figure 4-63

In Figure 4-63, please click direction arrows to adjust PTZ position. There are total 8 direction

arrows.



Figure 4-64

In the middle of the eight direction arrows, there is a 3D intelligent positioning key. See Figure 4-73. Please make sure your protocol supports this function and you need to use mouse to control.

Click this button, system goes to fast positioning interface. Click one position, the PTZ goes to the corresponding position and it becomes the centre of the screen. It supports zoom function. You can use mouse to drag. It supports 4X-16X speed. Press mouse and drag from top to the bottom, it is to zoom in. Press mouse and then drag from bottom to the top, it is to zoom out.



Figure 4-65

In Figure 4-63, please click the “set” button. The interface is shown as below. See Figure 4-66. Here you can set the following items:

- Preset
- Tour
- Pattern
- Border



Figure 4-66

In Figure 4-63, click page switch button, the interface is shown as in Figure 4-67. Here you can activate the following functions:

- Preset
- Tour
- Pattern
- Auto scan
- Auto pan
- Flip
- Reset
- Page switch

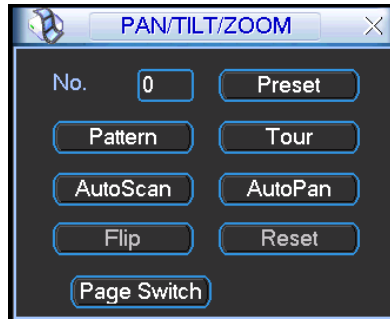

Figure 4-67

**Note:**

- Preset, tour and pattern all need the value to be the control parameter. You can define it as you require.
- You need to refer to your speed dome user’s manual for Aux definition. In some cases, it can be used for special process.
- The following setups are usually operated in the Figure 4-63, Figure 4-66 and Figure 4-67.

**Preset Setup**

In Figure 4-63, use eight direction arrows to adjust camera to the proper position.

In Figure 4-66, click preset button and input preset number. The interface is shown as in Figure 4-68.

Now you can add this preset to one tour.

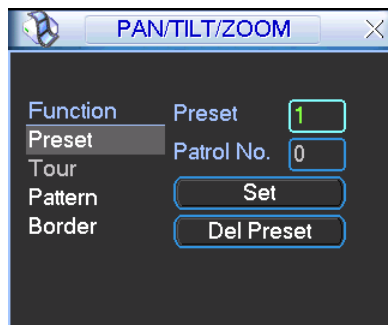

Figure 4-68

**Activate Preset**

In Figure 4-67, please input preset number in the No. blank, and click preset button.

**Patrol setup (Tour Setup)**

In Figure 4-38, click patrol button. The interface is shown as in Figure 4-69. Input preset number and add this preset to a patrol (tour).



Figure 4-69

### Activate Patrol (tour)

In Figure 4-66, input patrol (tour) number in the No. blank and click patrol button

### Pattern Setup

In Figure 4-66, click pattern button and then click “begin” button. The interface is shown as in Figure 4-70. Then you can go to Figure 4-63 X to modify zoom, focus, and iris.

Go back to Figure 4-70 and click “end” button. You can memorize all these operations as pattern 1.



Figure 4-70

### Activate Pattern Function

In Figure 4-39, input mode value in the No. blank, and click pattern button.

### Auto Scan Setup

In Figure 4-38, click border button. The interface is shown as in Figure 4-43.

Please go to Figure 4-35, use direction arrows to select camera left limit

Then please go to Figure 4-43 and click left limit button

Repeat the above procedures to set right limit.



Figure 4-71

### Activate Auto Scan

In Figure 4-67, click “Auto Scan” button, the system begins auto scan. Correspondingly, the auto scan button becomes Stop button. Click stop button to terminate scan operation.

### Flip

In Figure 4-67, click page switch button, you can see an interface is shown as below. See Figure 4-72. Here you can set auxiliary function. The aux value has relation ship with the Aux button of the decoder.

Click page switch button again, system goes back to Figure 4-63.

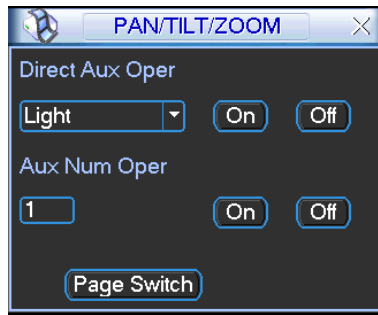



Figure 4-72

### 4.7.9 Display

Display setup interface is shown as below. See Figure 4-73.

- Transparency: Here is for you to adjust transparency. The value ranges from 128 to 255.
- Channel name: Here is for you to set local or remote network camera channel name. System max support 25-digit (The value may vary due to different series).
- Time display: You can select to display time or not when system is playback.
- Car number display: You can select to display plate number or not when system is playback.
- GPS display: System displays GPS information in the screen for your reference. **Please note only the unit of GPS module supports this function.**
- Temperature title: Check the box here to display the temperature.
- Resolution: There are five options: 1920×1080, 1280×1024, 1280×720, 1024×768, 800×600(default). Please note system needs to reboot to active current setup.
- Image enhance: Check the box; you can optimize the margin of the preview video.
- Tour setup: Here you can activate tour function. Click Setup button, you can see an interface shown as in Figure 4-75.
  - ✧ Enable tour: Highlight box here to enable this function.
  - ✧ Interval: System supports 1/4/8/9/16-window tour. Input proper interval value here. The value ranges from 5-120 seconds. It is for schedule tour/alarm/motion detect tour.
  - ✧ Split: You can select window split mode from the dropdown list.
  - ✧ Channel group: It is for you to view channel names under current window split mode. You can add/delete channel here.
  - ✧ Add: Under specified window split mode, click it to add channel group.
  - ✧ Delete: Click it to remove selected channel group.
  - ✧ Move up: Click it to move current selected channel up.
  - ✧ Move down: Click it to move current selected channel down.
  - ✧ Default: Click it to restore default setup.
- Enable tour: activate tour function.
- Interval: Input proper interval value here. The value ranges from 5-120 seconds. In tour process, you can use mouse or click Shift to turn on window switch function.  Stands for opening switch function,  stands for closing switch function.
- Motion tour type: System supports 1 window tour.
- Alarm tour type: System supports 1 window tour.

Please highlight icon  to select the corresponding function.

After completing all the setups please click save button, system goes back to the previous menu.

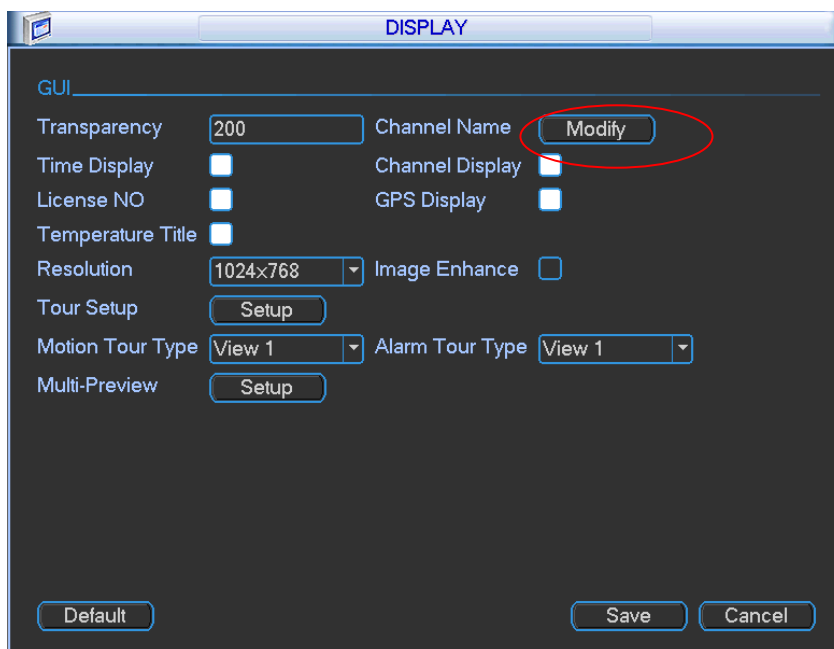

Figure 4-73

In Figure 4-73, click modify button after channel. You can see an interface shown as in Figure 4-74. Please note all your modification here applies to local end only. You need to refresh web or client-end to get the latest channel name. System max support 25-digital character.

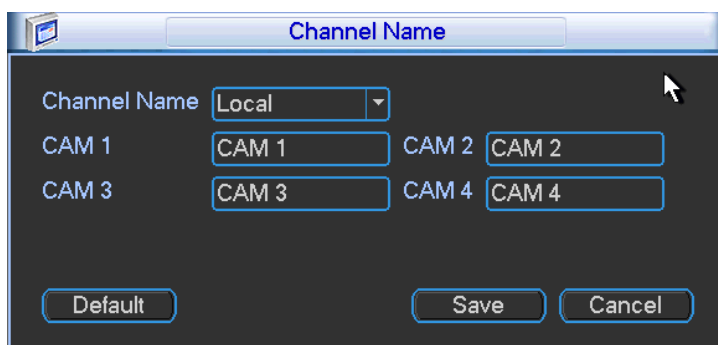

Figure 4-74

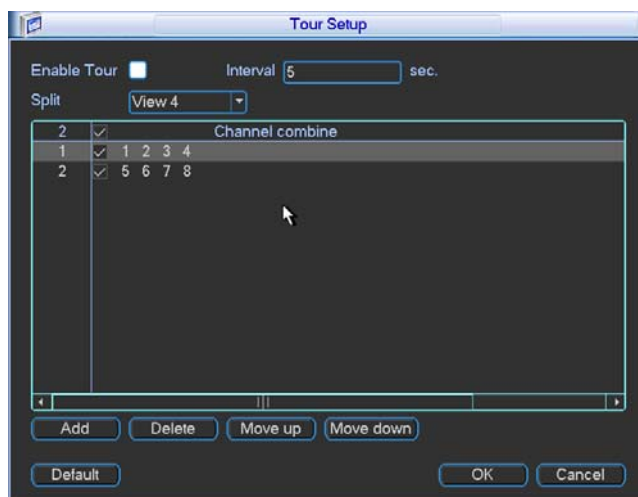



Figure 4-75

In tour mode, you can see the following interface. On the right corner, right click mouse or click shift button, you can control the tour. There are two icons:  stands for enabling window switch and  stands for disabling window function. See Figure 4-75.

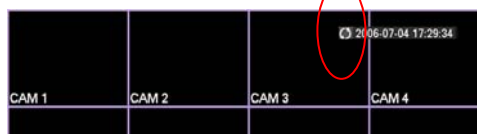

Figure 4-76

### Multiple-Window preview

In Figure 4-73, click multiple-preview setup button, you can go to the following interface. See Figure 4-77.

- Enable; Check the box here to enable this function.
- Compression: H.264.
- Resolution: you can select from the dropdown list.
- Frame rate: PAL: 1-25.NTSC:1-30.
- Bit rate: Default setup is 1024Kb/S.

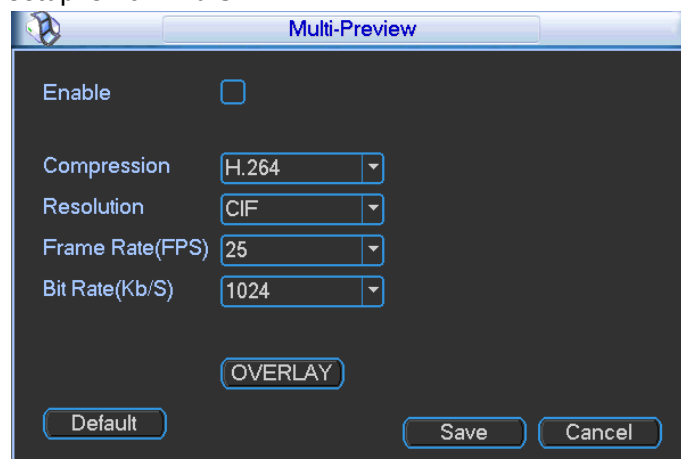



Figure 4-77

### 4.7.10 Default

Click default icon, system pops up a dialogue box. You can highlight  to restore default factory setup.

- Select all
- General
- Schedule
- RS232
- Network
- Alarm
- Detect
- Pan/tilt/zoom
- Display
- Channel name

- Remote device

Please highlight icon  to select the corresponding function. See Figure 4-78. After all the setups please click OK button, system goes back to the previous menu.

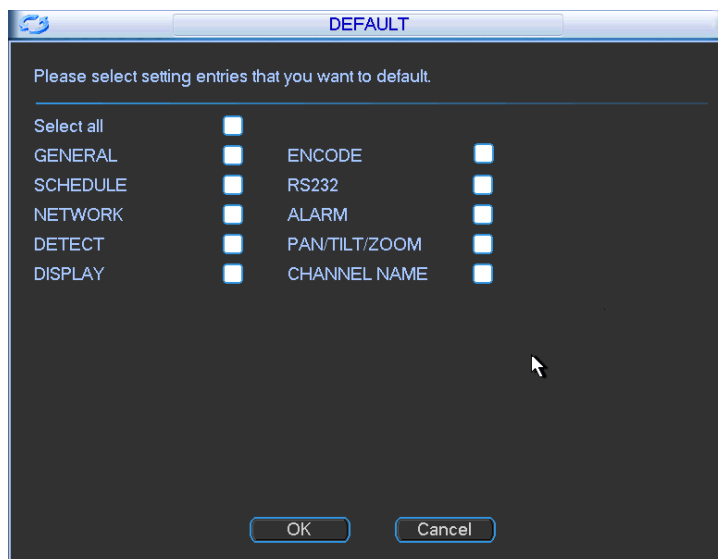

Figure 4-78

**Warning!**

System menu color, language, time display mode, video format, IP address, user account will not maintain previous setup after default operation!

## 4.8 Advanced

Double click advanced icon in the main window, the interface is shown as below. See Figure 4-79. There are total nine function keys: HDD management, alarm output, abnormality, manual record, account, auto maintenance, TV adjust, config backup and vehicle setting.

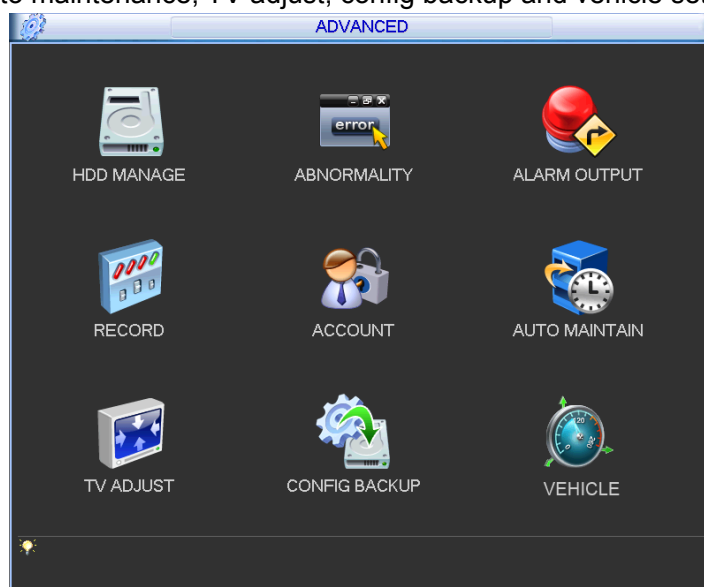

Figure 4-79

### 4.8.1 HDD Management

Here is for you to view and implement hard disk management. See Figure 4-80.

You can see current HDD type, status, capacity and record time. When HDD is working properly, system is shown as O. When HDD error occurred, system is shown as X.

- Alarm set: Click alarm set button, the interface is shown as below. See Figure 4-81. (This interface is just like the abnormality setup). Please refer to chapter 4.8.2 for detailed information.
- HDD operation: You can select HDD mode from the dropdown list such as read-only or you can erase all data in the HDD. Please note system needs to reboot to get all the modification activated.

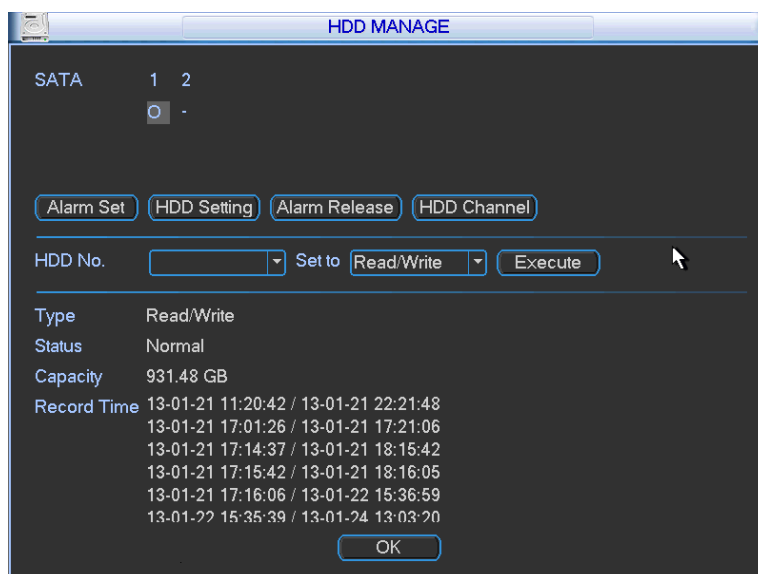

Figure 4-80

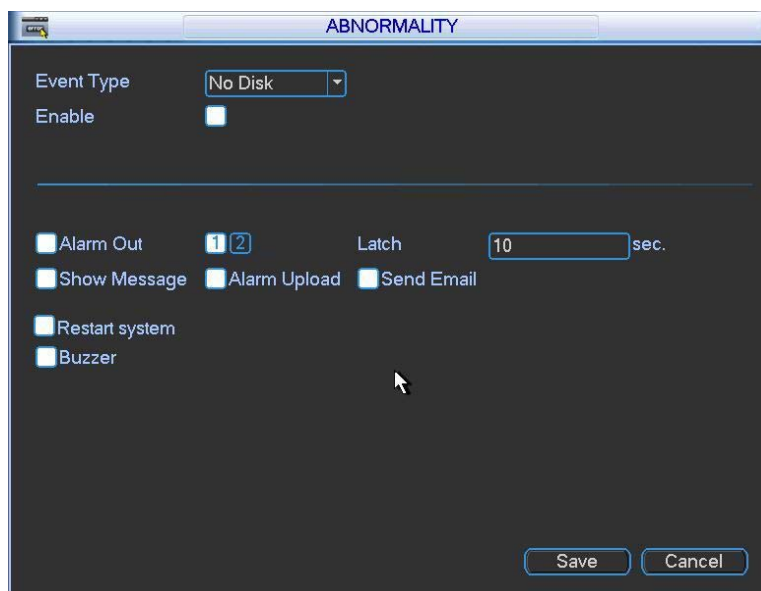

Figure 4-81

## 4.8.2 Abnormality

Abnormality interface is shown as in Figure 4-82.

- Event type: There are several options for you such as disk error, no disk, no space, high temperature, low battery and etc (multiple choices).

- Alarm output: Please select alarm activation output port (multiple choices).
- Latch: Here you can set corresponding delaying time. The value ranges from 1s-300s. System automatically delays specified seconds in turning off alarm and activated output after external alarm cancelled.
- Show message: system can pop up the message in the local screen to alert you when an alarm occurs.
- Alarm upload: System can upload the alarm signal to the network (including alarm centre) if you enabled current function.
- Send email: System can send out email to alert you when an alarm occurs.
- Restart system: If you highlight the button here, system will restart automatically if there is no HDD.
- Buzzer: Highlight the icon to enable this function. The buzzer beeps when an alarm occurs.

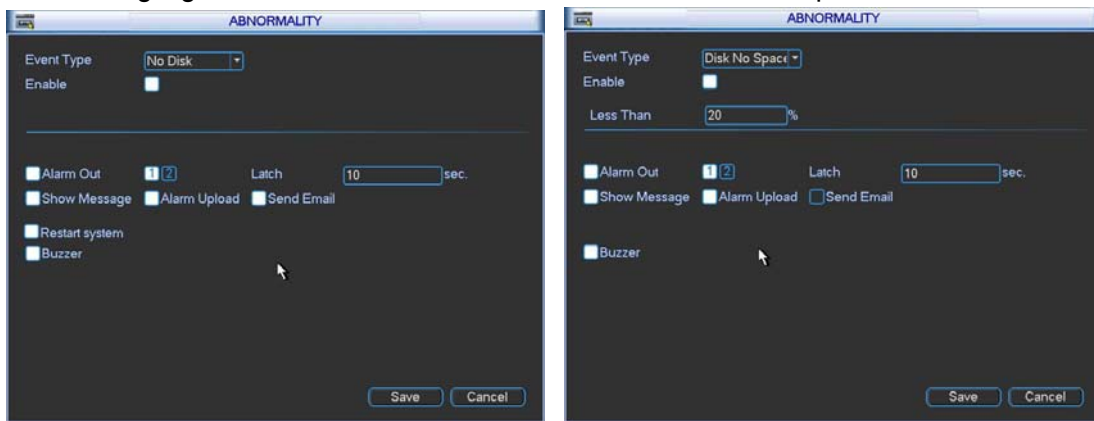

Figure 4-82

### 4.8.3 Alarm Output

Here is for you to set proper alarm output.

Please highlight icon  to select the corresponding alarm output.

After all the setups please click OK button, system goes back to the previous menu. See Figure 4-83.

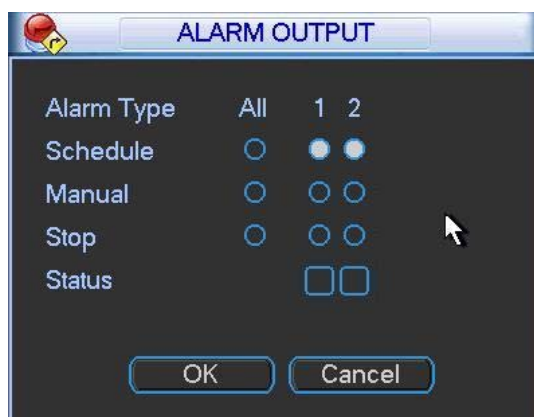

Figure 4-83

### 4.8.4 Manual Record

**Note:**

You need to have proper rights to implement the following operations. Please make sure the

HDD has been properly installed.

#### 4.8.4.1 Manual record menu

Right click mouse or in the main menu, Advanced->Manual Record.

Manual record menu is shown as in Figure 4-84.

#### 4.8.4.2 Basic operation

There are two streams: main stream/extra stream. There are three statuses: schedule/manual/stop. Please highlight icon “○” to select corresponding channel.

- Manual: The highest priority. After manual setup, all selected channels will begin ordinary recording.
- Schedule: Channel records as you have set in recording setup (Main Menu->Setting->Schedule)
- Stop: All channels stop recording.



Figure 4-84

#### 4.8.4.3 Enable/disable record

Please check current channel status: “○” means it is not in recording status, “●” means it is in recording status.

You can use mouse or direction key to highlight channel number. See Figure 4-85.



Figure 4-85

#### 4.8.4.4 Enable all channel recording

Highlight  below All, you can enable all channel recording.

- All channel schedule record

Please highlight “ALL” after “Schedule”. See Figure 4-86.

When system is in schedule recording, all channels will record as you have previously set (Main menu->Setting->Schedule).

The corresponding indication light in front panel will turn on.



Figure 4-86

- All channel manual record

Please highlight “ALL” after “Manual.” See Figure 4-87.

When system is in manual recording, all scheduled set up you have set in will be null ((Main menu->Setting->Schedule)).

You can see indication light in front panel turns on, system begins manual record now.



Figure 4-87

#### 4.8.4.5 Stop all channel recording

Please highlight “ALL” after “Stop”. See Figure 4-88.

System stops all channel recording no matter what mode you have set in the menu (Main menu->Setting->Schedule)



Figure 4-88

### 4.8.5 Account

Here is for you to implement account management. See Figure 4-89. Here you can:

- Add new user
- Modify user
- Add group
- Modify group
- Modify password.

For account management please note:

- For the user account name and the user group, the string max length is 6-byte. The backspace in front of or at the back of the string is invalid. There can be backspace in the middle. The string includes the valid character, letter, number, underline, subtraction sign, and dot.
- System account adopts two-level management: group and user. No limit to group or user amount.
- For group or user management, there are two levels: admin and user.
- The user name and group name can consist of eight bytes. One name can only be used once. There are four default users: admin/888888/666666 and hidden user "default". Except user 6666, other users have administrator right.
- Hidden user "default" is for system interior use only and can not be deleted. When there is no login user, hidden user "default" automatically login. You can set some rights such as monitor for this user so that you can view some channel view without login.
- One user should belong to one group. User right can not exceed group right.
- About reusable function: this function allows multiple users use the same account to login.

After all the setups please click save button, system goes back to the previous menu.

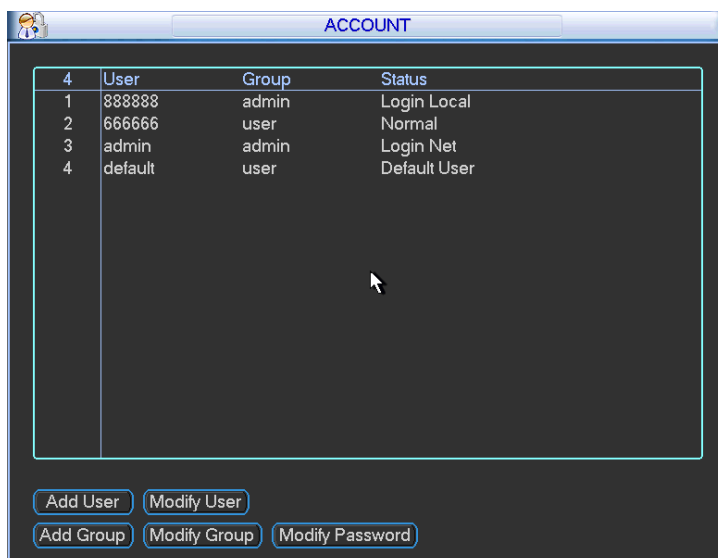

Figure 4-89

#### 4.8.5.1 Modify Password

Click password button, the interface is shown as in Figure 4-90.

Here you can modify account password.

Please select the account from the dropdown list, input the old password and then input the new password twice. Click the Save button to confirm current modification.

For the users of user account right, it can modify password of other users.

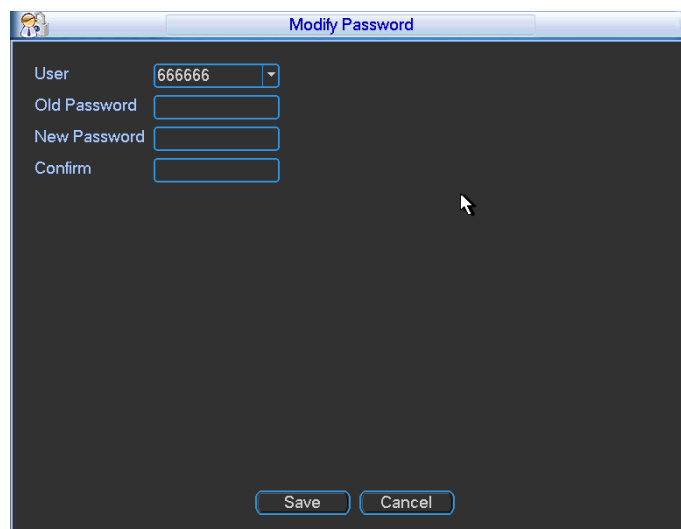

Figure 4-90

#### 4.8.5.2 Add/Modify Group

Click add group button, the interface is shown as below. See Figure 4-91.

Here you can input group name and then input some memo information if necessary.

There are total 60 rights such as control panel, shut down, real-time monitor, playback, record, record file backup, PTZ, user account, system information view, alarm input/output setup, system setup, log view, clear log, upgrade system, control device and etc.

The modify group interface is similar to the Figure 4-91.

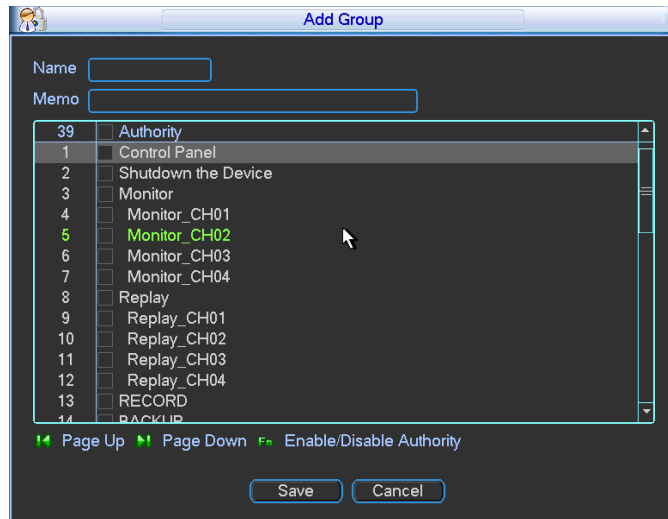

Figure 4-91

#### 4.8.5.3 Add/Modify User

Click add user button, the interface is shown as in Figure 4-92.

Please input the user name, password, select the group it belongs to from the dropdown list.

Then you can check the corresponding rights for current user.

For convenient user management, usually we recommend the general user right is lower than the admin account.

The modify user interface is similar to Figure 4-92.

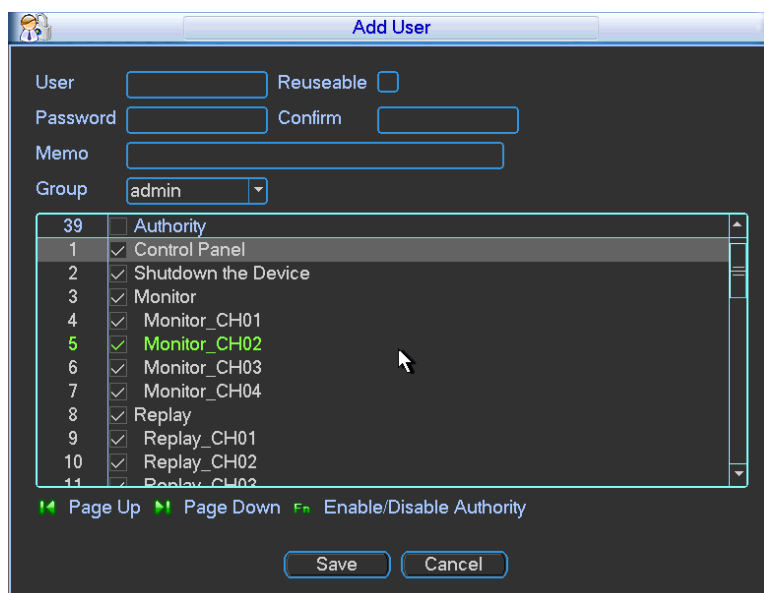

Figure 4-92

#### 4.8.6 Auto Maintenance

Here you can set auto-reboot time and auto-delete old files, auto shutdown, and auto ACC delay (0-65535 minutes) setup. You can set to delete the files for the specified days. See Figure 4-93.

After all the setups please click save button, system goes back to the previous menu.

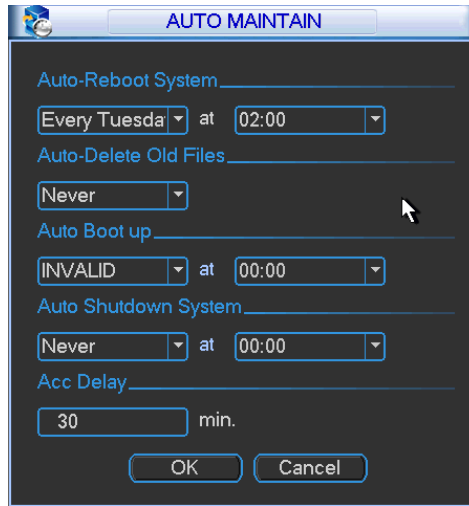

Figure 4-93

### 4.8.7 TV Adjust

Here is for you to adjust TV output setup. See Figure 4-94.

Please drag slide bar to adjust each item. The value ranges from 0 to 100.

After all the setups please click OK button, system goes back to the previous menu.

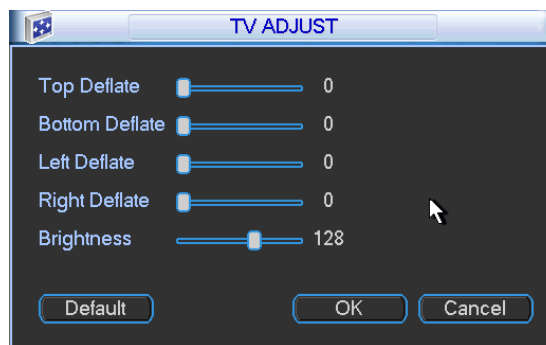

Figure 4-94

### 4.8.8 Config Backup

The configuration file backup interface is shown as below. See Figure 4-95.

This function allows you to copy current system configuration to other devices. It also supports import, create new folder, and delete folder and etc function.

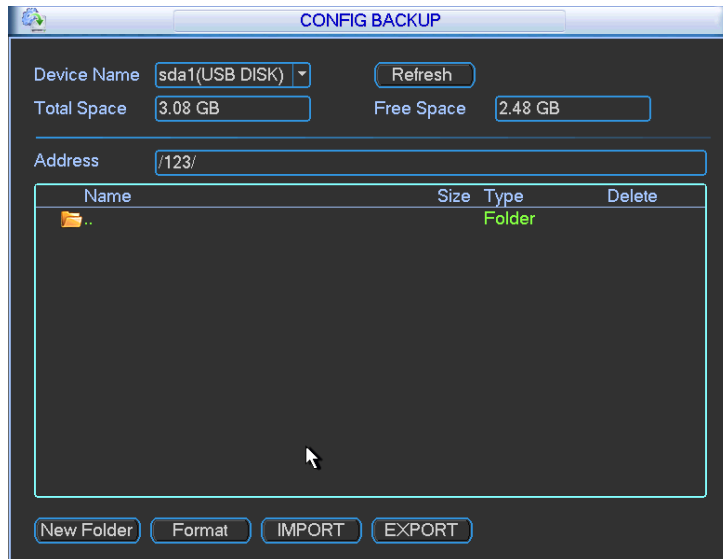

Figure 4-95

### 4.8.9 Vehicle Setting

Here you can view or set vehicle gravity sensor and GPS setup information. See Figure 4-96.

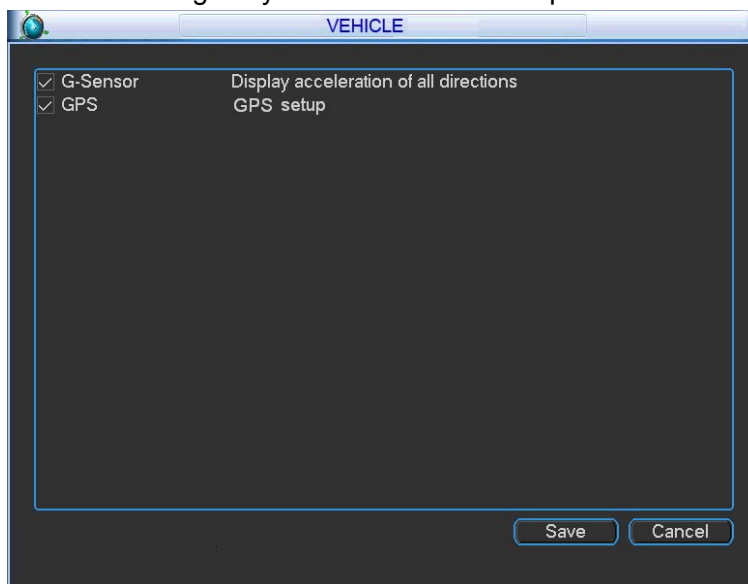

Figure 4-96

Double click gravity sensor, you can view the gravity acceleration. See Figure 4-97.

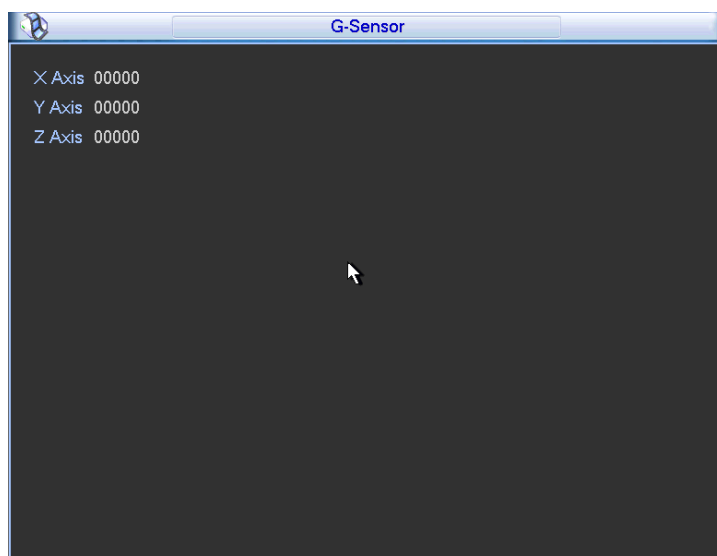

Figure 4-97

Click GPS button, you can view current GPS module type. See Figure 4-98.

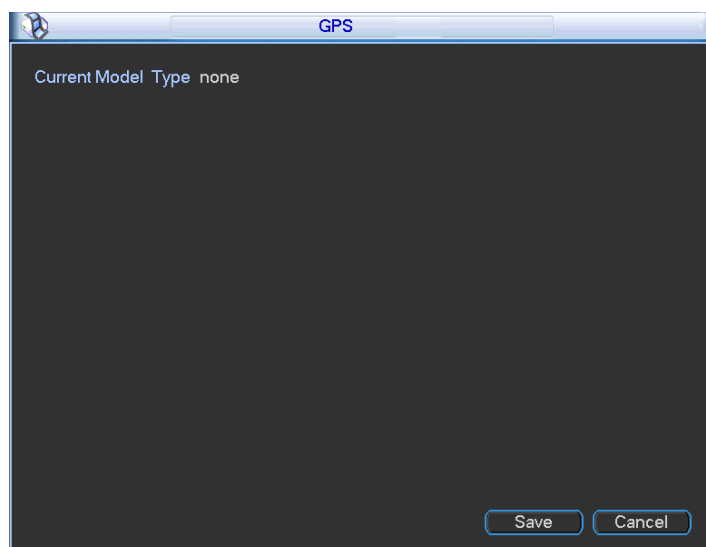

Figure 4-98

## 4.9 Backup

DVR supports USB device and etc. Here we introduce USB backup. You can refer to Chapter 5 Web Operation for network download backup operation.

### 4.9.1 Detect Device

Click backup button, you can see an interface is shown as in Figure 4-99. Here is for you to view device information. You can view backup device name and its total space and free space.

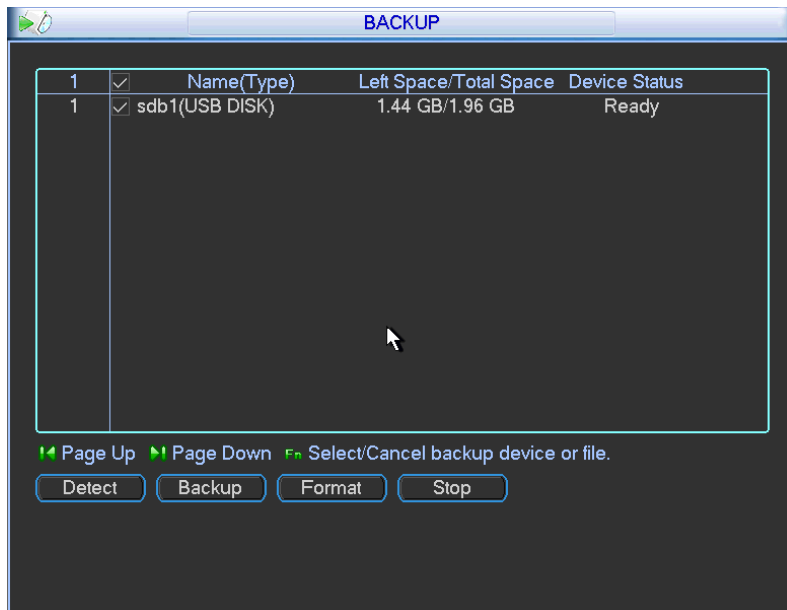

Figure 4-99

## 4.9.2 Backup

Select backup device and then set channel, file start time and end time.

Click add button, system begins search. All matched files are listed below. System automatically calculates the capacity needed and remained. See Figure 4-100.

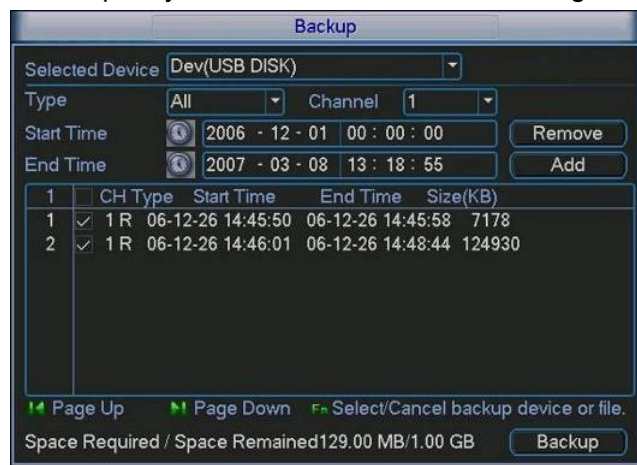

Figure 4-100

System only backup files with a ✓ before channel name. You can use AUX button to check or cancel file.

Click backup button, you can backup selected files. There is a process bar for you reference. See

Figure 4-101. Click backup button, system begins burning. At the same time, the backup button becomes stop button. You can view the remaining time and process bar at the left bottom.

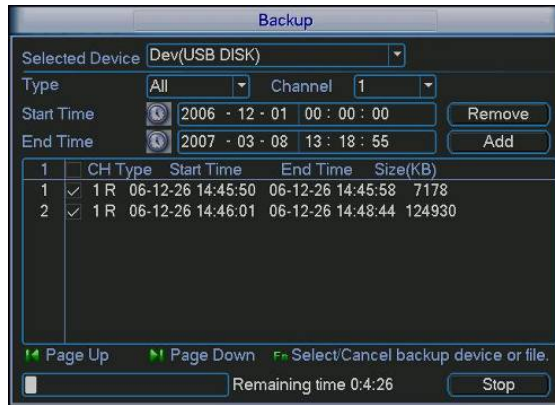

Figure 4-101

When the system completes backup, you can see a dialogue box prompting successful backup.

The file name format usually is: SN\_CH+channel number+Time. In the file name, the YDM format is Y+M+D+H+M+S. File extension name is .dav.

**Tips:**

During backup process, you can click ESC to exit current interface for other operation. The system will not terminate backup process.

**Note:**

When you click stop button during the burning process, the stop function becomes activated immediately. For example, if there are ten files, when you click stop system just backup five files, system only save the previous 5 files in the device (But you can view ten file names).

**4.9.3 One key backup**

Insert backup device to the USB port at the front panel and click the F1 button of the remote control, system automatically backup current record files to the device.

**4.10 Shutdown**

Double click shutdown button, system pops up a dialogue box for you to select. See Figure 4-102.

- Logout menu user: log out menu. You need to input password when you login the next time.
- Restart application: reboot device.
- Shutdown: system shuts down and turns off power.
- Restart system: system begins rebooting.
- Switch user: you can use another account to login.

If you shut down the device, there is a process bar for your reference, system waits for 3 seconds and then shut down (You can not cancel).

Please note, sometimes you need to input the proper password to shut down the device.



Figure 4-102

## 5 WEB OPERATION

There might be slightly difference in the interface due to different series.

### 5.1 Network Connection

Before web operation, please check the following items:

- Network connection is right
- DVR and PC network setup is right. Please refer to network setup(Setup ->Network)
- Use order ping `***.***.***.***`(\* DVR IP address) to check connection is OK or not. Usually the return TTL value should be less than 255.
- Open the IE and then input DVR IP address.
- System can automatically download latest web control and the new version can overwrite the previous one.
- If you want to un-install the web control, please run `uninstall webrec3.0.bat`. Or you can go to `C:\Program Files\webrec` to remove single folder. Please note, before you un-install, please close all web pages, otherwise the un-installation might result in error.
- Current series product supports IE browser only.

### 5.2 Login

Open IE and input DVR address in the address column. For example, if your DVR IP is 10.10.3.16, then please input `http:// 10.10.3.16` in IE address column. See Figure 5-1.

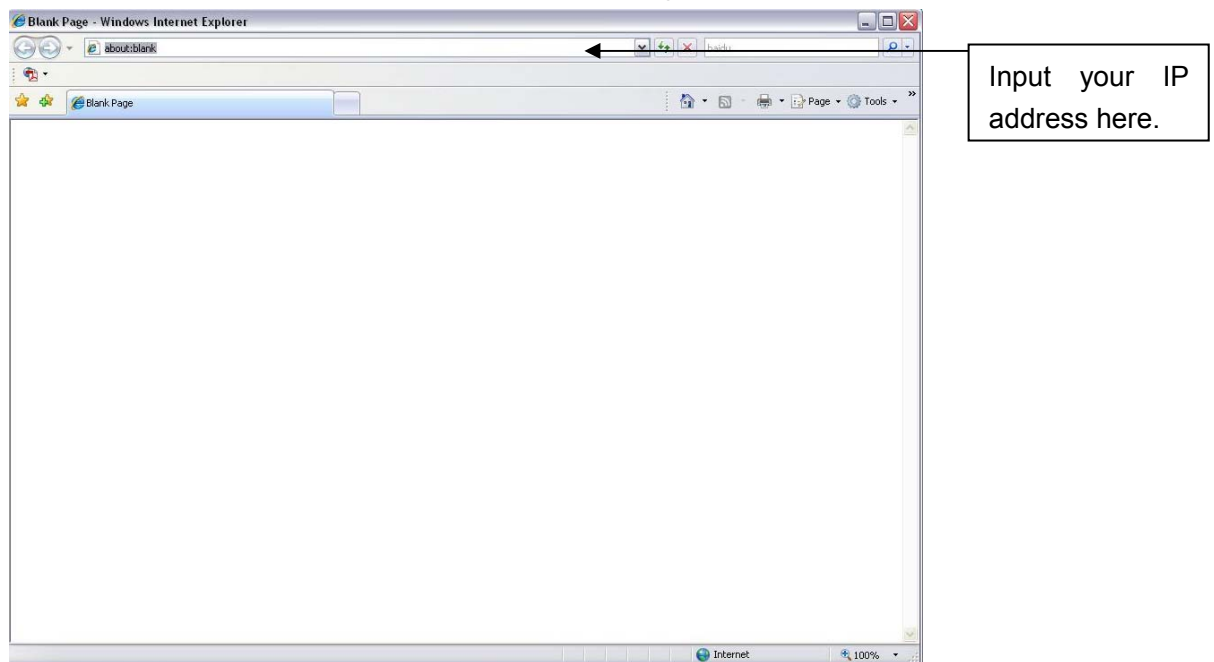

Figure 5-1

System pops up warning information to ask you whether install webrec.cab control or not. Please click yes button.

If you can't download the ActiveX file, please modify your settings as follows. See Figure 5-2.

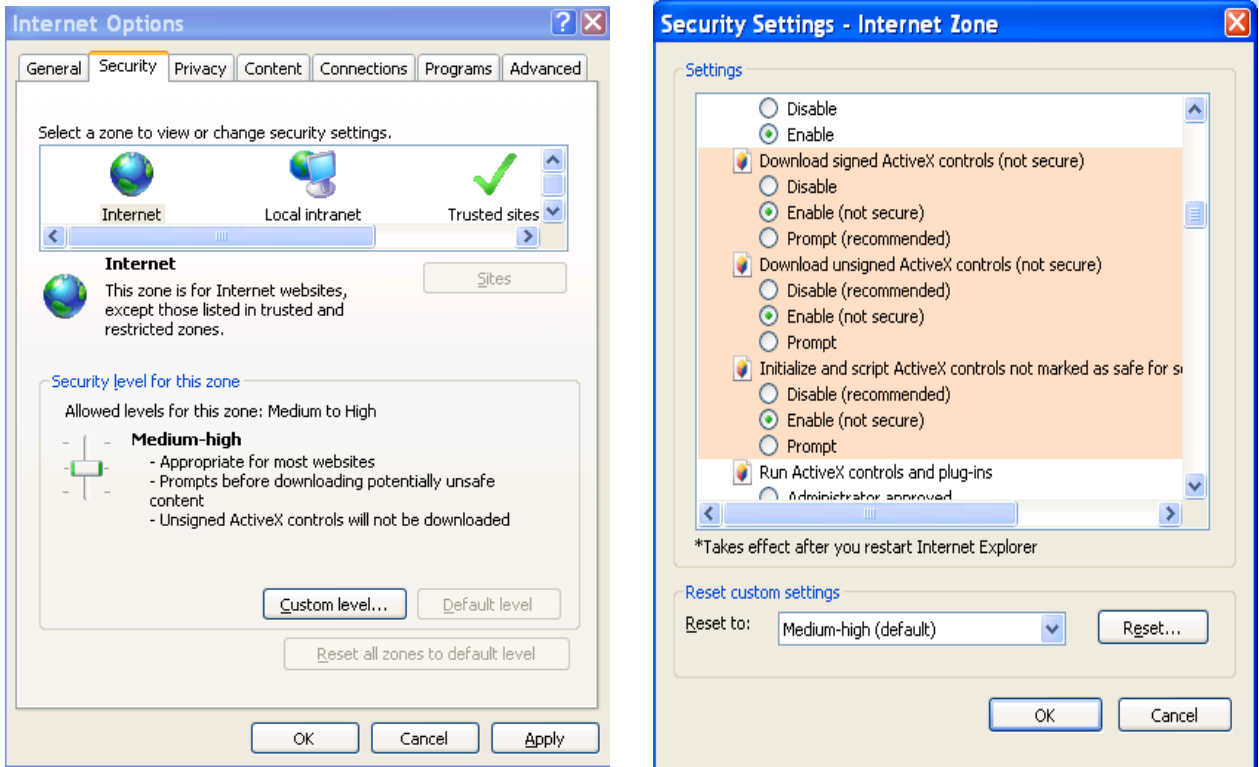

Figure 5-2

After installation, the interface is shown as below. See Figure 5-3.

Please input your user name and password.

Default factory name is **admin** and password is **admin**.

Then you can select the login mode: LAN and WAN.

**Note:** For security reasons, please modify your password after you first login.

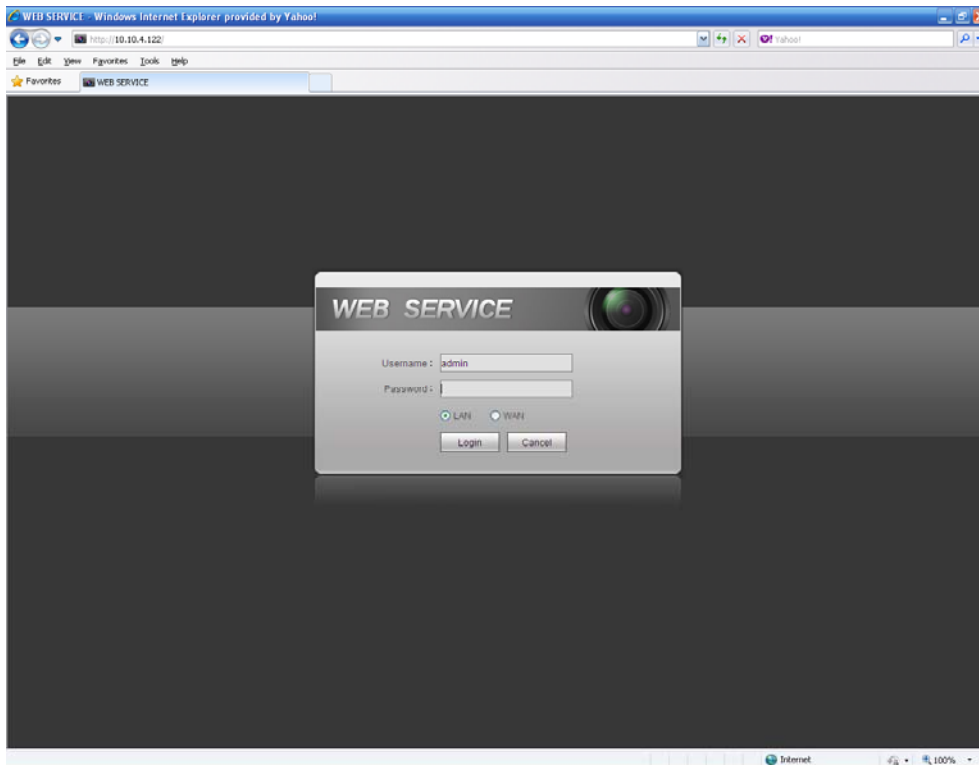

Figure 5-3

### 5.3 LAN Mode

For the LAN mode, after you logged in, you can see the main window. See Figure 5-9.

This main window can be divided into the following sections.

- Section 1: there are five function buttons: Live (chapter 5.4) , setup (chapter 5.8), search (chapter 5.9), alarm (chapter 5.10), and logout (chapter 5.11).
- Section 2: There are channel number and one button: Start all. Start all button is to enable/disable all-channel real-time monitor. Click it the button becomes yellow. See Figure 5-4.

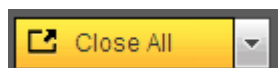

Figure 5-4

Please refer to Figure 5-5 for main stream and extra stream switch information.

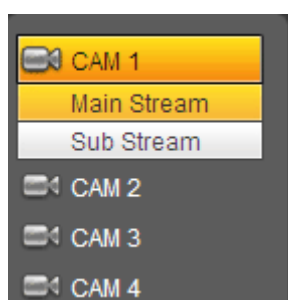

Figure 5-5

- Section 3: Start dialogue button.

You can click this button to enable audio talk. Click **▼** to select bidirectional talk mode. There are four options: DEFAULT, G711a, G711u and PCM. After you enable the bidirectional talk, the Start talk button becomes End Talk button and it becomes yellow. See Figure 5-6.

Please note, the audio input port from the device to the client-end is using the first channel audio input port. During the bidirectional talk process, system will not encode the audio data from the 1-channel.

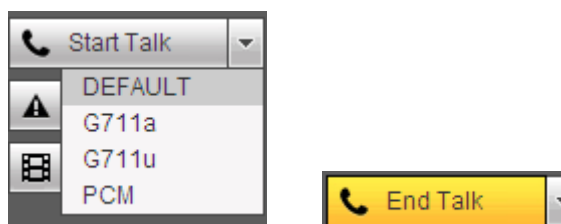

Figure 5-6

- Section 4: Instant record button. Click it, the button becomes yellow and system begins manual record. See Figure 5-7. Click it again, system restores previous record mode..

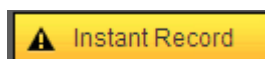

Figure 5-7

- Section 5: Local play button.

The Web can playback the saved (Extension name is dav) files in the PC-end.

Click local play button, system pops up the following interface for you to select local play file. See Figure 5-8.



Figure 5-8

- Section 6: From the left to the right ,you can see video quality/fluency/ full screen/1-window/4-window/6-window/8-window/9-window/13-window/16-window/20-window/25-window/36-window.. You can set video fluency and real-time feature priority.
- Section 7: PTZ operation panel. Please refer to chapter 5.5 for detailed information.
- Section 8: Image setup and alarm setup. Please refer to chapter 5.6 for detailed information.

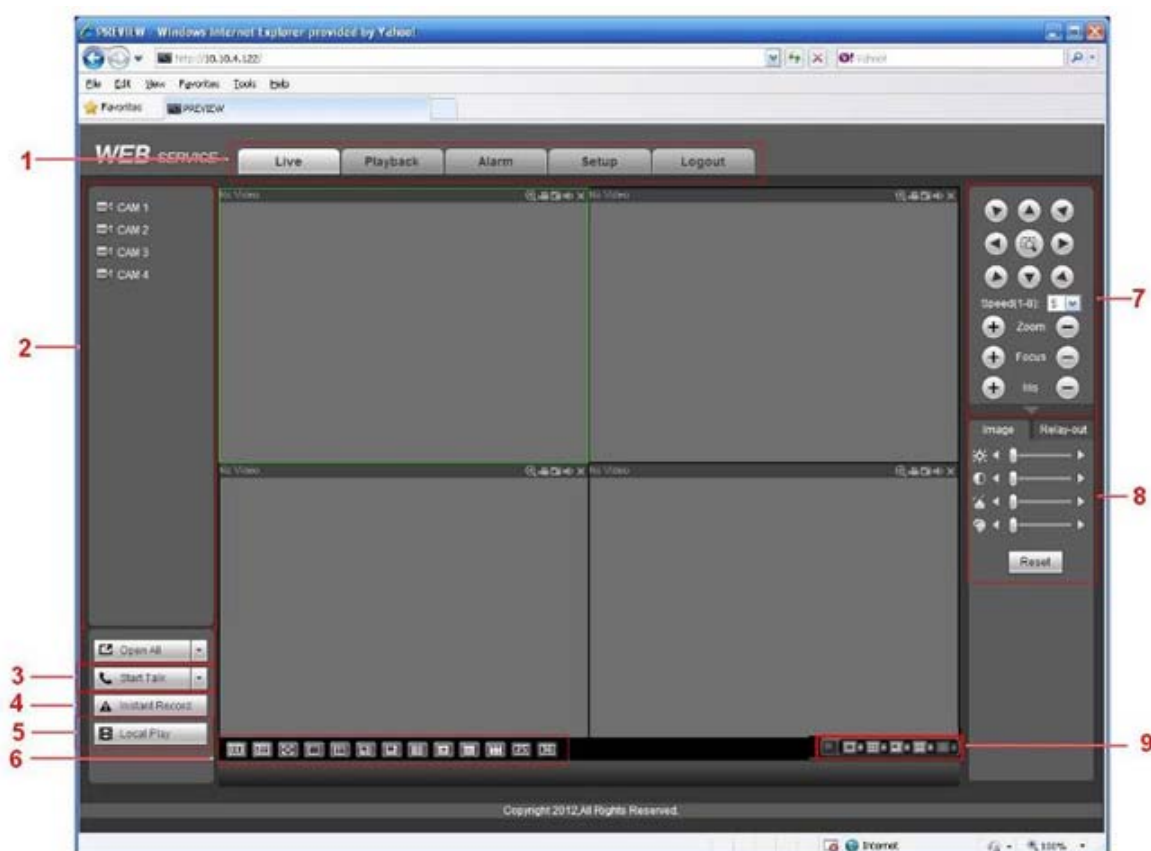

Figure 5-9

## 5.4 Real-time Monitor

In section 2, left click the channel name you want to view, you can see the corresponding video in current window.

On the top left corner, you can view device IP, channel number, network monitor bit stream. See Figure 5-10.

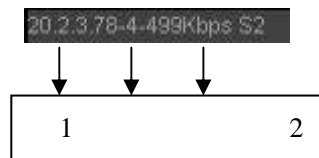

Figure 5-10

On the top right corner, there are six function buttons. See Figure 5-11.

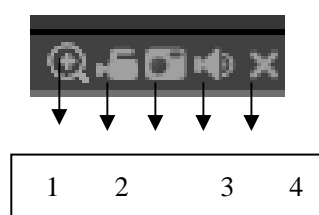

Figure 5-11

- 1: Digital zoom: Click this button and then left drag the mouse in the zone to zoom in. right click mouse system restores original status.
- 2: Local record. When you click local record button, the system begins recording and this button becomes highlighted. You can go to system folder RecordDownload to view the recorded file.
- 3: Snapshot picture. You can snapshot important video. All images are memorized in system client folder PictureDownload (default).
- 4: Audio :Turn on or off audio.(It has no relationship with system audio setup )
- 5: Close video.

## 5.5 PTZ

Before PTZ operation, please make sure you have properly set PTZ protocol. (Please refer to chapter 5.8.5.9).

There are eight direction keys. In the middle of the eight direction keys, there is a 3D intelligent positioning key.

Click 3D intelligent positioning key, system goes back to the single screen mode. Drag the mouse in the screen to adjust section size. It can realize PTZ automatically.

Please refer to the following sheet for PTZ setup information.

| Parameter | Function   |
|-----------|--|
| Scan      | <ul style="list-style-type: none"> <li>● Select Scan from the dropdown list.</li> <li>● Click Set button, you can set scan left and right limit.</li> <li>● Use direction buttons to move the camera to you desired location and then click left limit button. Then move the camera again and then click right limit button to set a right limit.</li> </ul> |

| Parameter       | Function   |
|-----------------|--|
| Preset          | <ul style="list-style-type: none"> <li>● Select Preset from the dropdown list.</li> <li>● Turn the camera to the corresponding position and Input the preset value. Click Add button to add a preset,.</li> </ul>  |
| Tour            | <ul style="list-style-type: none"> <li>● Select Tour from the dropdown list.</li> <li>● Input preset value in the column. Click Add preset button, you have added one preset in the tour.</li> <li>● Repeat the above procedures you can add more presets in one tour.</li> <li>● Or you can click delete preset button to remove one preset from the tour.</li> </ul> |
| Pattern         | <ul style="list-style-type: none"> <li>● Select Pattern from the dropdown list.</li> <li>● You can input pattern value and then click Start button to begin PTZ movement such as zoom, focus, iris, direction and etc. Then you can click Add button to set one pattern.</li> </ul>  |
| Aux             | <ul style="list-style-type: none"> <li>● Please input the corresponding aux value here.</li> <li>● You can select one option and then click AUX on or AUX off button.</li> </ul>   |
| Light and wiper | You can turn on or turn off the light/wiper.   |

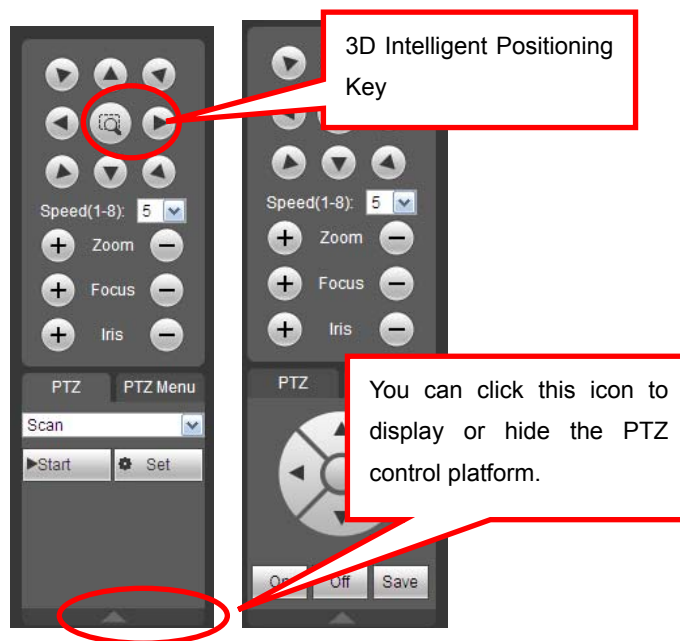

Figure 5-12

## 5.6 Image/Relay-out

Select one monitor channel video and then click Image button in section 8, the interface is shown as Figure 5-13.

### 5.6.1 Image

Here you can adjust its brightness, contrast, hue and saturation. (Current channel border

becomes green).

Or you can click Reset button to restore system default setup.

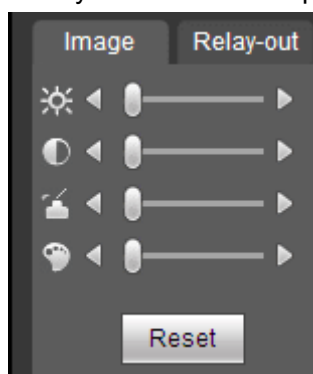

Figure 5-13

### 5.6.2 Relay output

Here you can select alarm output channel, the select channel alarm mode becomes manual and alarm is enabled. See Figure 5-14. It is corresponding to the alarm output 1 (A1) and alarm output 2 (A2) of the rear panel.

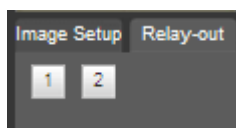

Figure 5-14

### 5.6.3 Multiple-channel preview

System allows you to preview several channels on one channel. It supports 1/4-window. See Figure 5-15.

**Please note only the product of this icon can support current function.**



Figure 5-15

## 5.7 WAN Login

In WAN mode, after you logged in, the interface is shown as below. See Figure 5-16.



Figure 5-16

Please refer to the following contents for LAN and WAN login difference.

- 1) In the WAN mode, system opens the main stream of the first channel to monitor by default. The open/close button on the left pane is null.
- 2) You can select different channel and different monitor mode at the bottom of the interface.
- 3) Multiple-channel monitor, system adopts extra stream to monitor by default. Double click one channel, system switches to single channel and system uses main stream to monitor. You can view there are two icons at the left top corner of the channel number for you reference. M stands for main stream. S stands for sub stream (extra stream).
- 4) If you login via the WAN mode, system does not support alarm activation to open the video function in the Alarm setup interface.

### Important

- For multiple-channel monitor mode, system adopts extra stream to monitor by default. You can not modify manually. All channels are trying to synchronize. Please note the synchronization effect still depends on your network environments.
- For bandwidth consideration, system can not support monitor and playback at the same time. System auto closes monitor or playback interface when you are searching setup in the configuration interface. It is to enhance search speed.

## 5.8 Setup

### 5.8.1 Channel

#### 5.8.1.1 Conditions

Here you can view device property information. The setups become valid immediately after you set. See Figure 5-17.

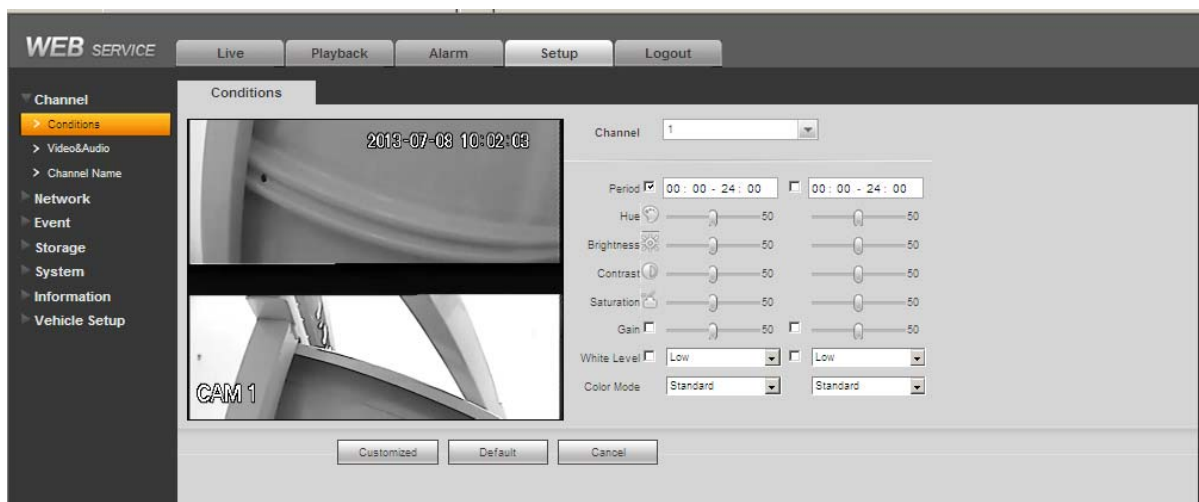

Figure 5-17

Please refer to the following sheet for detailed information.

| Parameter  | Function  |
|------------|---|
| Channel    | Please select a channel from the dropdown list.   |
| Period     | It divides one day (24 hours) to two periods. You can set different hue, brightness, and contrast for different periods.  |
| Hue        | It is to adjust monitor video brightness and darkness level. The default value is 50.<br>The bigger the value is, the large the contrast between the bright and dark section is and vice versa.   |
| Brightness | It is to adjust monitor window brightness. The default value is 50.<br>The larger the number is, the bright the video is. When you input the value here, the bright section and the dark section of the video will be adjusted accordingly. You can use this function when the whole video is too dark or too bright. Please note the video may become hazy if the value is too high. The value ranges from 0 to 100. The recommended value ranges from 40 to 60.                                 |
| Contrast   | It is to adjust monitor window contrast. The value ranges from 0 to 100. The default value is 50.<br>The larger the number is, the higher the contrast is. You can use this function when the whole video bright is OK but the contrast is not proper. Please note the video may become hazy if the value is too low. If this value is too high, the dark section may lack brightness while the bright section may over exposure. The recommended value ranges from 40 to 60.                     |
| Saturation | It is to adjust monitor window saturation. The value ranges from 0 to 100. The default value is 50.<br>The larger the number is, the strong the color is. This value has no effect on the general brightness of the whole video. The video color may become too strong if the value is too high. For the grey part of the video, the distortion may occur if the white balance is not accurate. Please note the video may not be attractive if the value is too low. The recommended value ranges |

|             |  |
|-------------|--|
|             | from 40 to 60.   |
| Gain        | The gain adjust is to set the gain value. The smaller the value is, the low the noise is. But the brightness is also too low in the dark environments. It can enhance the video brightness if the value is high. But the video noise may become too clear. |
| White level | It is to enhance video effect.   |
| Color mode  | It includes several modes such as standard, color. You can select corresponding color mode here, you can see hue, brightness, and contrast and etc will adjust accordingly.  |

### 5.8.1.2 Video and Audio

#### 5.8.1.2.1 Encode

The encode interface is shown as below. See Figure 5-18.



Figure 5-18

Please refer to the following sheet for detailed information.

| Parameter        | Function   |
|------------------|--|
| Channel          | Please select a channel from the dropdown list.  |
| Video enable     | Check the box here to enable extra stream video. This item is enabled by default.  |
| Code stream type | It includes main stream, motion stream and alarm stream. You can select different encode frame rates form different recorded events.<br><br>System supports active control frame function (ACF). It allows you to record in different frame rates.<br><br>For example, you can use high frame rate to record important events, record scheduled event in lower frame rate and it allows you to set different frame rates for motion detection record and alarm record. |
| Compression      | The main bit stream supports H.264. The extra stream supports H.264, MJPG.   |

|                    |   |
|--------------------|---|
| Resolution         | System supports various resolutions, you can select from the dropdown list. The main stream supports D1/HD1/CIF/2CIF/QCIF and the extra stream supports CIF/QCIF. Please note the option may vary due to different series.  |
| Frame Rate         | PAL: 1~25f/s; NTSC: 1~30f/s.  |
| Bit Rate           | <ul style="list-style-type: none"> <li>● Main stream: You can set bit rate here to change video quality. The large the bit rate is , the better the quality is. Please refer to recommend bit rate for the detailed information.</li> <li>● Extra stream: In CBR, the bit rate here is the max value. In dynamic video, system needs to low frame rate or video quality to guarantee the value. The value is null in VBR mode.</li> </ul> |
| Reference bit rate | Recommended bit rate value according to the resolution and frame rate you have set.   |
| Audio enable       | System supports G711a/PCM/G711 μ .  |
| Watermark enable   | This function allows you to verify the video is tampered or not. Here you can select watermark bit stream, watermark mode and watermark character. Default character is DigitalCCTV. The max length is 85-digit. The character can only include number, character and underline.  |

### 5.8.1.2.2 Snapshot

The snapshot interface is shown as in Figure 5-19.

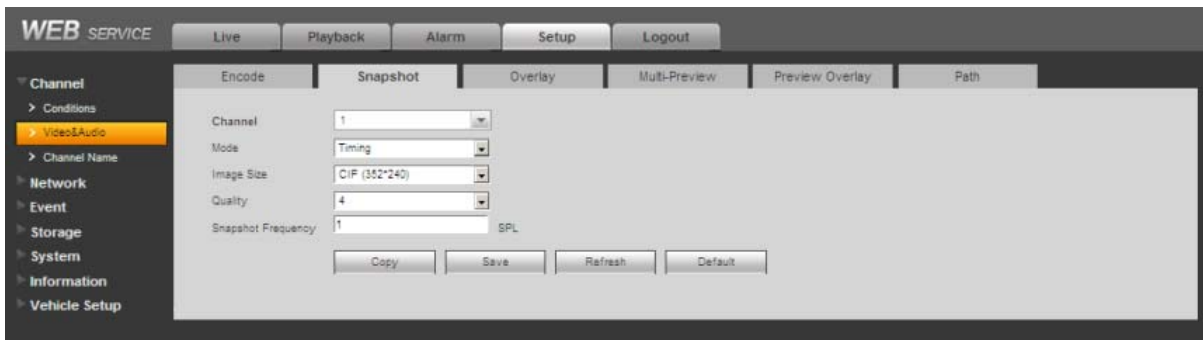

Figure 5-19

Please refer to the following sheet for detailed information.

| Parameter     | Function   |
|---------------|--|
| Snapshot type | There are two modes: Timing (schedule) and Event (activation). <ul style="list-style-type: none"> <li>● Timing snapshot is valid during the specified period you set.</li> <li>● Activation snapshot only is valid when motion detect alarm, camera masking alarm or local activation alarm occurs.</li> </ul> |
| Image size    | It is the same with the resolution of the main stream.   |
| Quality       | It is to set the image quality. There are six levels.  |
| Interval      | It is to set snapshot frequency.   |

|      |   |
|------|---|
| Copy | Click it; you can copy current channel setup to other channel(s). |
|------|---|

### 5.8.1.2.3 Video Overlay

The video overlay interface is shown as in Figure 5-20.

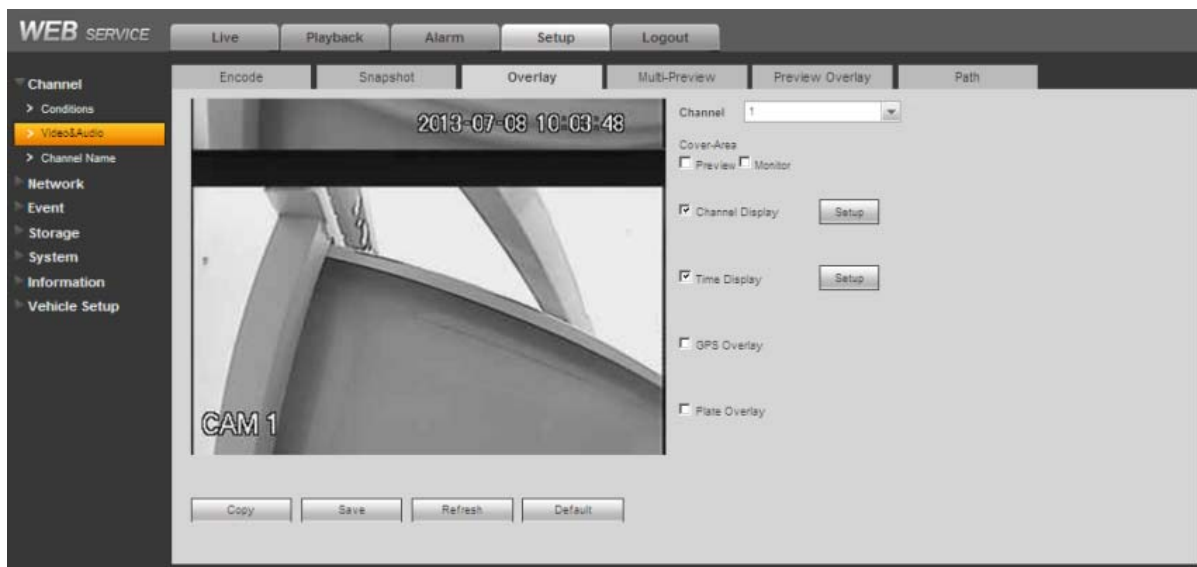

Figure 5-20

Please refer to the following sheet for detailed information.

| Parameter                    | Function   |
|------------------------------|--|
| Cover-area<br>(Privacy mask) | Check Preview or Monitor first.<br>Click Set button, you can privacy mask the specified video in the preview or monitor video.<br>System max supports 4 privacy mask zones.  |
| Time Title                   | You can enable this function so that system overlays time information in video window.<br>You can use the mouse to drag the time title position.<br>You can view time title on the live video of the WEB or the playback video.          |
| Channel Title                | You can enable this function so that system overlays channel information in video window.<br>You can use the mouse to drag the channel title position.<br>You can view channel title on the live video of the WEB or the playback video. |
| GPS Overlay                  | Overlay GPS information such as (speed, longitude, latitude) on the video.   |
| Plate Overlay                | Overlay some plate information on the video.   |

### 5.8.1.2.4 Multiple-Preview

The multiple-preview interface is shown as in Figure 5-21.



Figure 5-21

Please refer to the following sheet for detailed information.

| Parameter      | Function              |
|----------------|-----------------------|
| Compression    | H.264                 |
| Resolution     | D1/HD1/CIF/2CIF/QCIF. |
| Frame Rate     | 1~25.                 |
| Bit Rate(kb/s) | 640/768/896/1024.     |

#### 5.8.1.2.5 Preview Overlay

The preview overlay interface is shown as in Figure 5-22. You can overlay time, speed, plate information and etc on the device preview interface and Web monitor video.

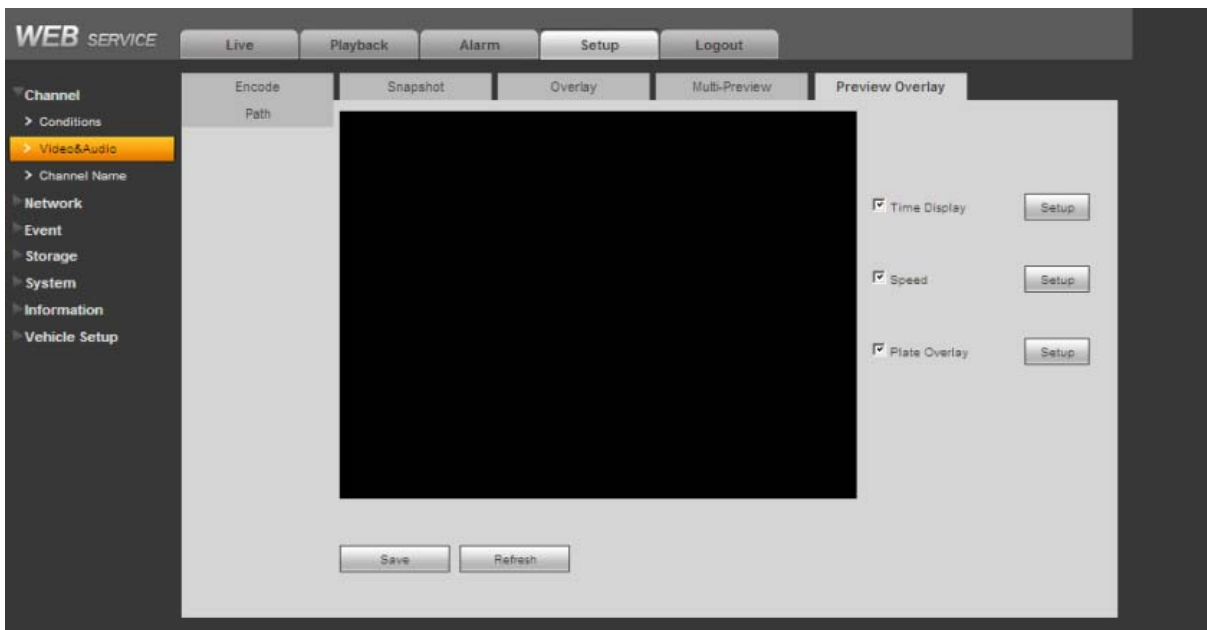

Figure 5-22

#### 5.8.1.2.6 Path

The storage path interface is shown as in Figure 5-23.

Here you can set snap image saved path and the record storage path. The default setup is C:\PictureDownload and C:\RecordDownload.

Please click the Save button to save current setup.

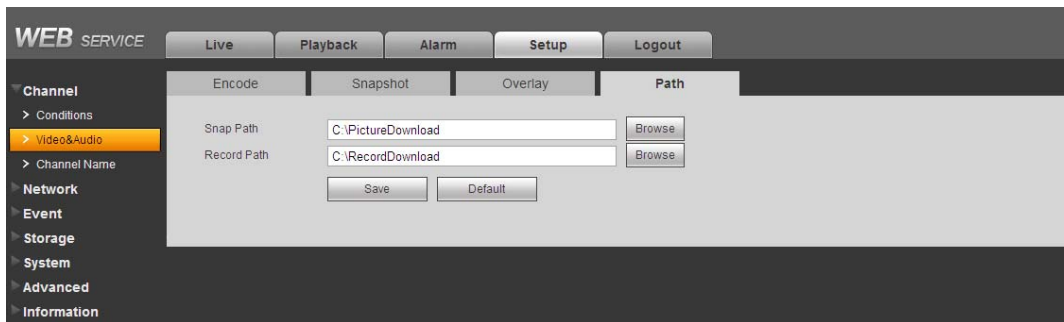

Figure 5-23

### 5.8.1.3 Channel Name

Here you can set channel name. See Figure 5-24.

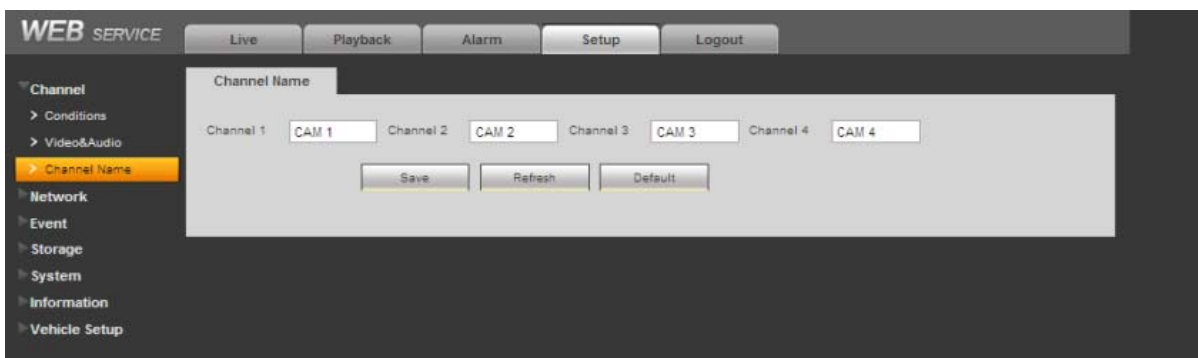

Figure 5-24

## 5.8.2 Network

### 5.8.2.1 TCP/IP

The TCP/IP interface is shown as in Figure 5-25.

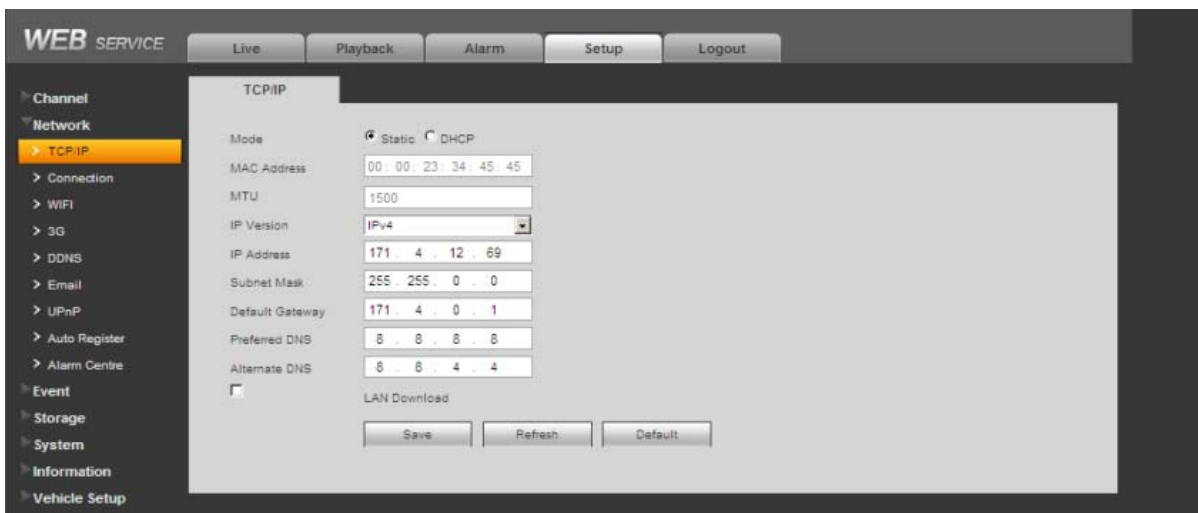

Figure 5-25

Please refer to the following sheet for detailed information.

| Parameter   | Function   |
|---|--|
| Mode  | <p>There are two modes: static mode and the DHCP mode.</p> <ul style="list-style-type: none"> <li>● The IP/submask/gateway are null when you select the DHCP mode to auto search the IP.</li> <li>● If you select the static mode, you need to set the IP/submask/gateway manually.</li> <li>● If you select the DHCP mode, you can view the IP/submask/gateway from the DHCP.</li> <li>● If you switch from the DHCP mode to the static mode, you need to reset the IP parameters.</li> </ul> |
| Mac Address   | It is to display host Mac address.   |
| MTU   | Max transmission unit.   |
| IP Version  | <p>It is to select IP version. IPV4 or IPV6.</p> <p>You can access the IP address of these two versions.</p>   |
| IP Address  | Please use the keyboard to input the corresponding number to modify the IP address and then set the corresponding subnet mask and the default gateway.   |
| Subnet Mask   | Input subnet mask according to your device IP.   |
| Default Gateway   | Input default gateway according to your device IP.   |
| Preferred DNS   | DNS IP address.  |
| Alternate DNS   | Alternate DNS IP address.  |
| <b>For the IP address of IPv6 version, default gateway, preferred DNS and alternate DNS, the input value shall be 128-digit. It shall not be left in blank.</b> |  |
| LAN load  | System can process the downloaded data first if you enable this function. The download speed is 1.5X or 2.0X of the normal speed.  |

### 5.8.2.2 Connection

The connection interface is shown as in Figure 5-26.

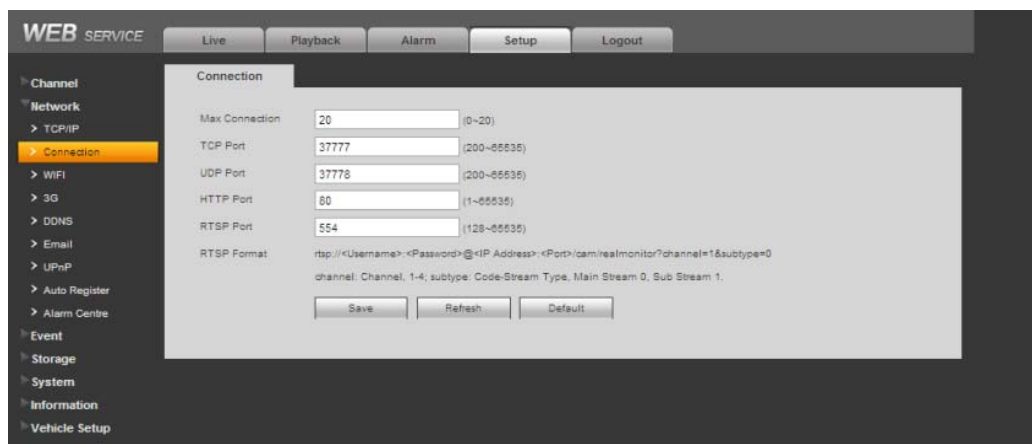

Figure 5-26

Please refer to the following sheet for detailed information.

| Parameter      | Function  |
|----------------|---|
| Max connection | It is the max Web connection for the same device. The value ranges from 1 to 20. The default setup is 20. |
| TCP port       | The default value is 37777. You can input the actual port number if necessary.                            |
| UDP port       | The default value is 37778. You can input the actual port number if necessary.                            |
| HTTP port      | The default value is 80. You can input the actual port number if necessary.                               |
| RTSP port      | The default value is 554.   |

### 5.8.2.3 WIFI

**Please note this function is for the device of WIFI module.**

The WIFI interface is shown as in Figure 5-27.

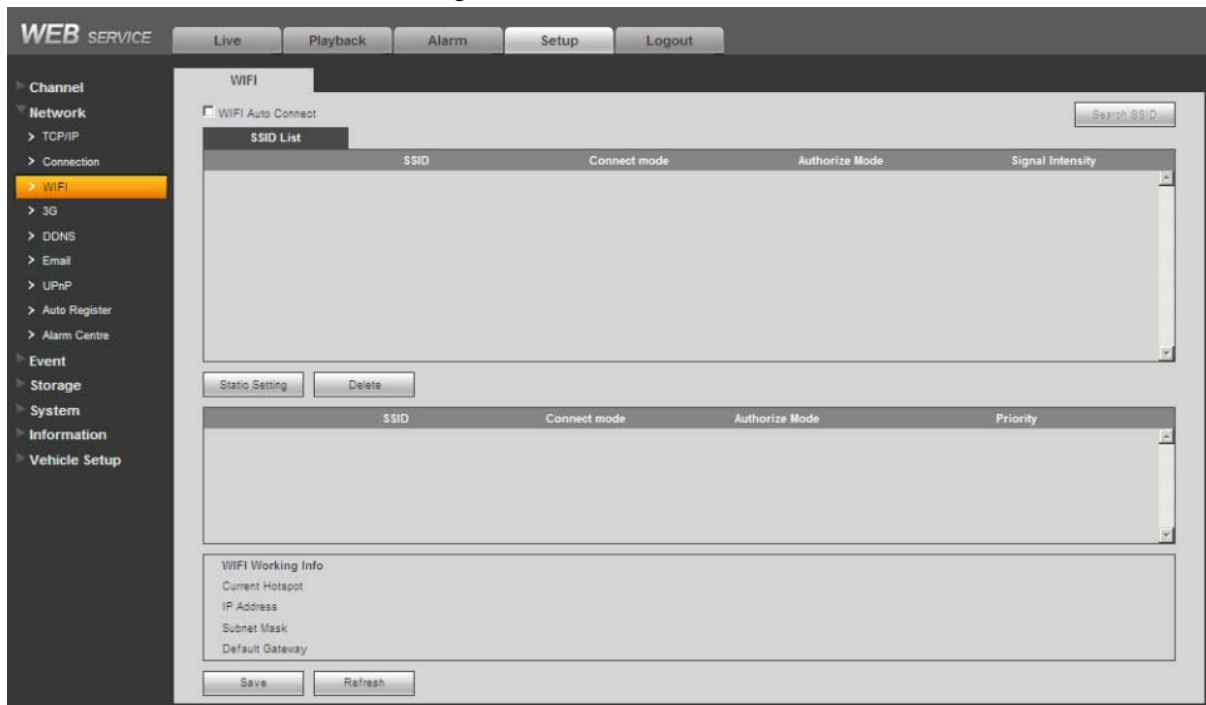

Figure 5-27

Please check the box to enable WIFI function and then click the Search SSID button. Now you can view all the wireless network information in the following list. Double click a name to connect to it. Click Refresh button, you can view latest connection status.

Click Static setting button, you can go to WIFI setup interface. Here you can input SSID (wireless network name) and verification type such as OPEN, WEP, WPA-PSK, and WPA2-PSK.

### 5.8.2.4 3G

#### 5.8.2.4.1 CDMA/GPRS

The CDMA/GPRS interface is shown as in Figure 5-28.

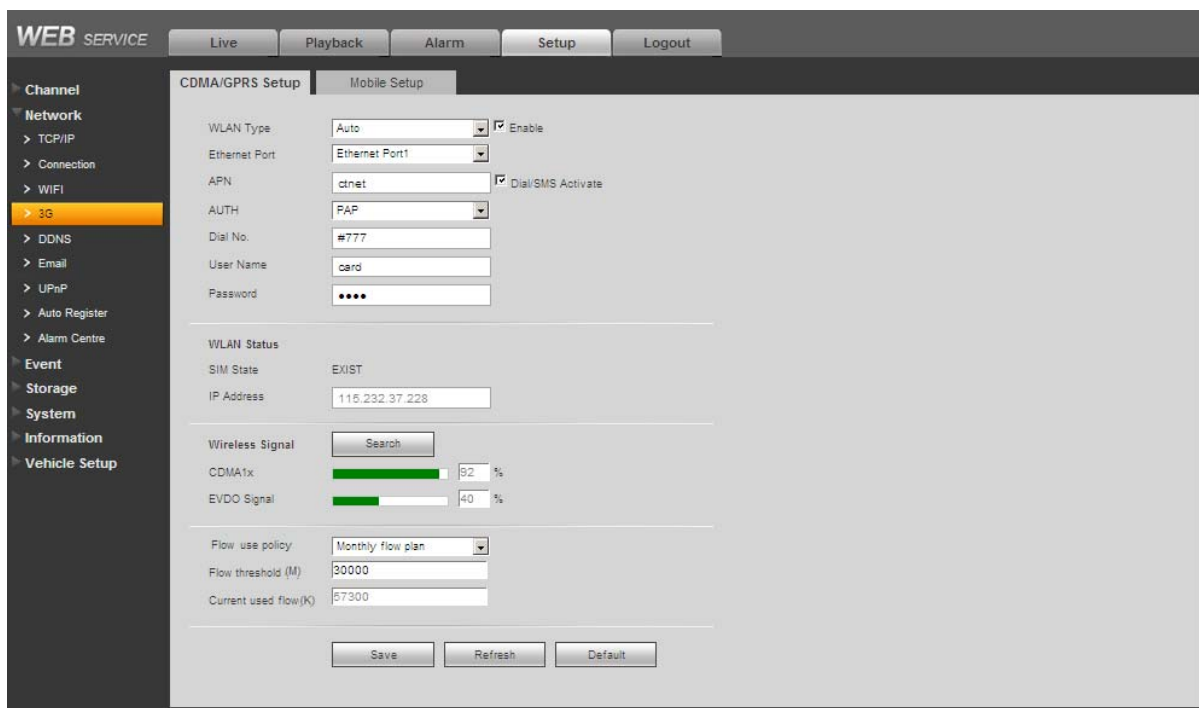

Figure 5-28

Please refer to the following sheet for detailed information.

| Parameter            | Function  |
|----------------------|---|
| WLAN type            | Here you can select 3G network type to distinguish the 3G module from different ISP. The types include WCDMA, CDMA1x and etc. |
| APN/.                | Here is the important parameter of PPP.   |
| Authorization        | It includes PAP,CHAP,NO_AUTH.   |
| Dial No              | The network dial number you got from your ISP.  |
| User Name            | The user name you login the 3G network.   |
| Password             | The password you login the 3G network.  |
| SIM State            | Display SIM card status.  |
| IP Address           | Input IP address.   |
| Wireless Signal      | Display signal intensity.   |
| Flow Use Policy      | Select flow policy.   |
| Flow Threshold(M)    | Set flow threshold.   |
| Current Used Flow(K) | Currently used flow.  |

#### 5.8.2.4.2 Mobile

The mobile setup interface is shown as in Figure 5-29.

Here you can activate or turn off the 3G connected phone or mobile phone, or the phone you set to get alarm message.

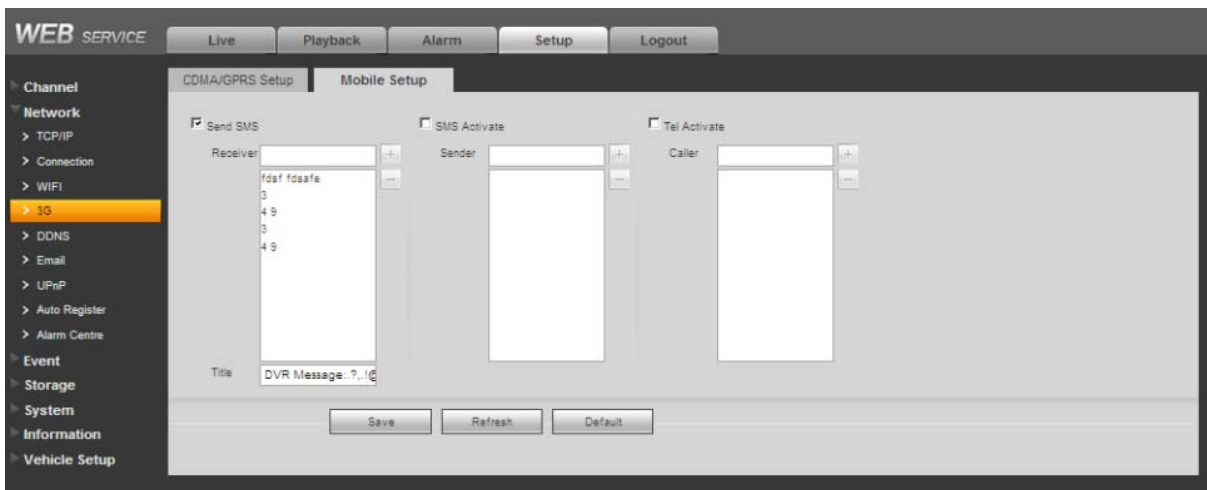

Figure 5-29

### 5.8.2.5 DDNS

The DDNS interface is shown as in Figure 5-30.

The DDNS is to set to connect the various servers so that you can access the system via the server. Please go to the corresponding service website to apply a domain name and then access the system via the domain. It works even your IP address has changed.

Please select DDNS from the dropdown list (Multiple choices). Before you use this function, please make sure your purchased device support current function.

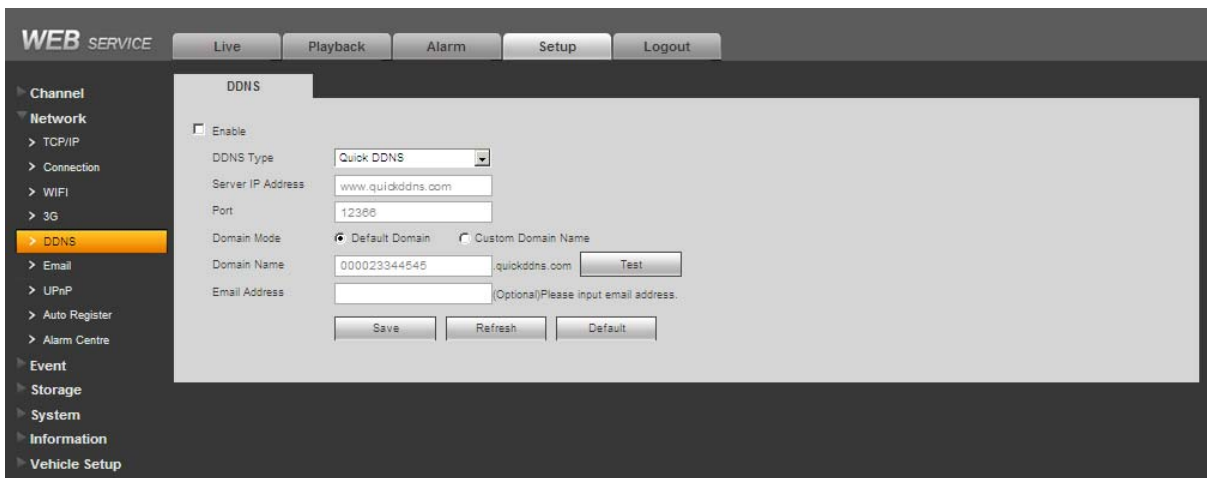

Figure 5-30

Please refer to the following sheet for detailed information.

| Parameter   | Function   |
|-------------|--|
| Server Type | You can select DDNS protocol from the dropdown list and then enable DDNS function. |
| Server IP   | DDNS server IP address   |
| Server Port | DDNS server port.  |
| Domain Name | Your self-defined domain name.   |
| User        | The user name you input to log in the server.                                      |
| Password    | The password you input to log in the server.                                       |

| Parameter     | Function  |
|---------------|---|
| Update period | Device sends out alive signal to the server regularly.<br>You can set interval value between the device and DDNS server here. |

## Quick DDNS and Client-end Introduction

### 1) Background Introduction

Device IP is not fixed if you use ADSL to login the network. The DDNS function allows you to access the DVR via the registered domain name. Besides the general DDNS, the quick DDNS works with the device from the manufacturer so that it can add the extension function.

### 2) Function Introduction

The quick DDNS client has the same function as other DDNS client end. It realizes the bonding of the domain name and the IP address. Right now, current DDNS server is for our own devices only. You need to refresh the bonding relationship of the domain and the IP regularly. There is no user name, password or the ID registration on the server. At the same time, each device has a default domain name (Generated by MAC address) for your option. You can also use customized valid domain name (has not registered.).

### 3) Operation

Before you use Quick DDNS, you need to enable this service and set proper server address, port value and domain name.

- Server address: [www.quickddns.com](http://www.quickddns.com)
- Port number: 80
- Domain name: There are two modes: Default domain name and customized domain name.

Except default domain name registration, you can also use customized domain name (You can input your self-defined domain name.) After successful registration, you can use domain name to login installed of the device IP.

- User name: It is optional. You can input your commonly used email address.

### Important

- Do not register frequently. The interval between two registrations shall be more than 60 seconds. Too many registration requests may result in server attack.
- System may take back the domain name that is idle for one year. You can get a notification email before the cancel operation if your email address setup is OK.

#### 5.8.2.6 Email

The email interface is shown as in Figure 5-31.

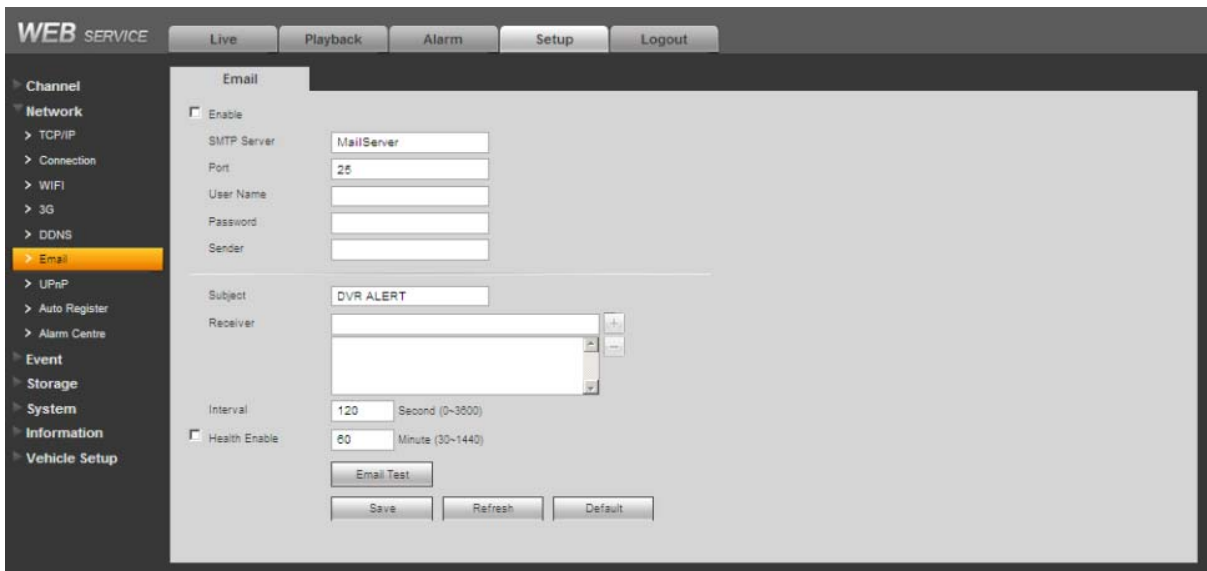

Figure 5-31

Please refer to the following sheet for detailed information.

| Parameter                        | Function   |
|----------------------------------|--|
| Enable                           | Please check the box here to enable email function.  |
| SMTP Server                      | Input server address and then enable this function.  |
| Port                             | Default value is 25. You can modify it if necessary.   |
| Anonymity                        | For the server supports the anonymity function. You can auto login anonymously. You do not need to input the user name, password and the sender information.   |
| User Name                        | The user name of the sender email account.   |
| Password                         | The password of sender email account.  |
| Sender                           | Sender email address.  |
| Authentication (Encryption mode) | You can select SSL or none.  |
| Subject                          | Input email subject here.  |
| Attachment                       | System can send out the email of the snapshot picture once you check the box here.   |
| Receiver                         | Input receiver email address here. Max three addresses. It supports SSL, TLS email box.  |
| Interval                         | The send interval ranges from 0 to 3600 seconds. 0 means there is no interval.<br>Please note system will not send out the email immediately when the alarm occurs. When the alarm, motion detection or the abnormality event activates the email, system sends out the email according to the interval you specified here. This function is very useful when there are too many emails activated by the abnormality events, which may result in heavy |

| Parameter                | Function  |
|--------------------------|---|
|                          | load for the email server.  |
| Health mail enable       | Please check the box here to enable this function.  |
| Update period (interval) | This function allows the system to send out the test email to check the connection is OK or not.<br>Please check the box to enable this function and then set the corresponding interval.<br>System can send out the email regularly as you set here. |
| Email test               | The system will automatically sent out a email once to test the connection is OK or not .Before the email test, please save the email setup information.  |

### 5.8.2.7 UPnP

It allows you to establish the mapping relationship between the LAN and the public network. Here you can also add, modify or remove UPnP item. See Figure 5-32.

- In the Windows OS, From Start->Control Panel->Add or remove programs. Click the “Add/Remove Windows Components” and then select the “Network Services” from the Windows Components Wizard.
- Click the Details button and then check the “Internet Gateway Device Discovery and Control client” and “UPnP User Interface”. Please click OK to begin installation.
- Enable UPnP from the Web. If your UPnP is enabled in the Windows OS, the DVR can auto detect it via the “My Network Places”



Figure 5-32

### 5.8.2.8 Auto Register

The auto register interface is shown as in Figure 5-33. After the device connects to the network, it can send out auto register query to the specified server.

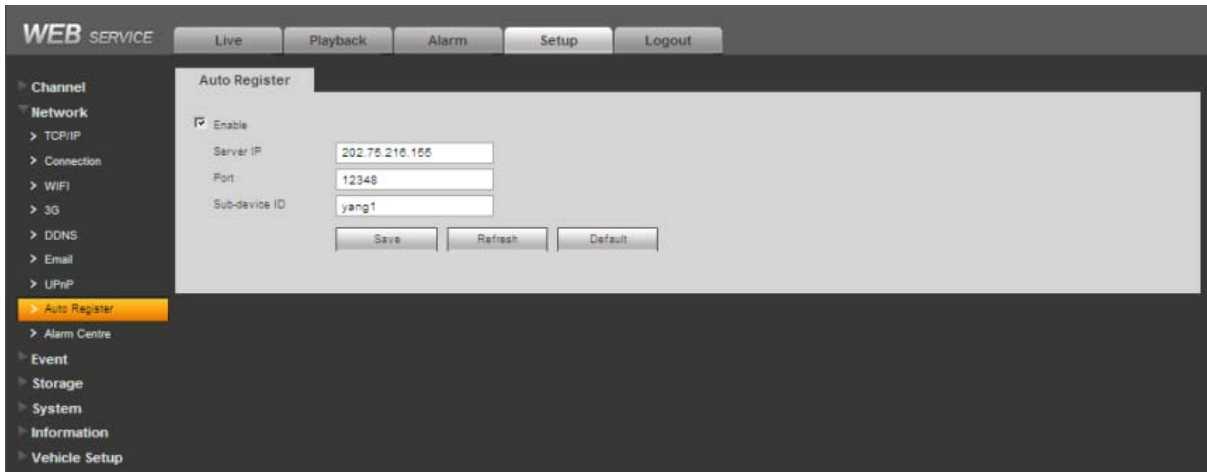

Figure 5-33

Please refer to the following sheet for detailed information.

| Parameter     | Function                        |
|---------------|---------------------------------|
| Server IP     | DSS server IP address.          |
| Port          | DSS server port value.          |
| Sub-device ID | The device ID set from the DSS. |

### 5.8.2.9 Alarm Centre

The alarm centre interface is shown as below. See Figure 5-34.

This interface is reserved for you to develop. System can upload alarm signal to the alarm centre when local alarm occurs.

Before you use alarm centre, please set server IP, port and etc. When an alarm occurs, system can send out data as the protocol defined, so the client-end can get the data.

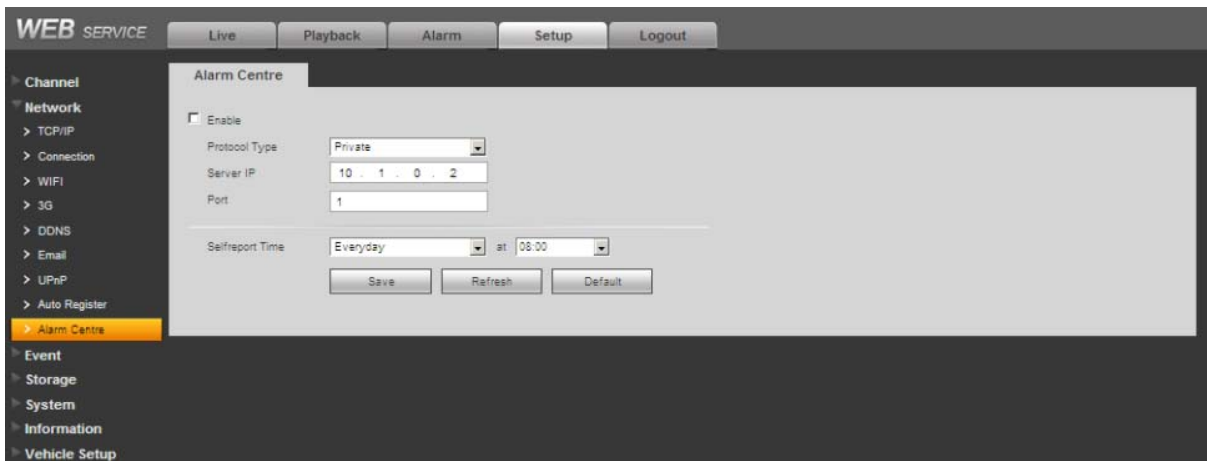

Figure 5-34

## 5.8.3 Event

### 5.8.3.1 Video detect

#### 5.8.3.1.1 Motion Detect

The motion detect interface is shown as in Figure 5-35.



Figure 5-35

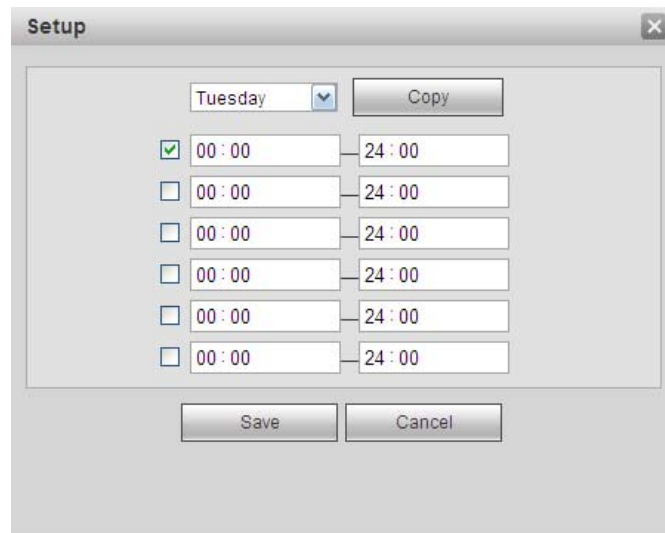

Figure 5-36

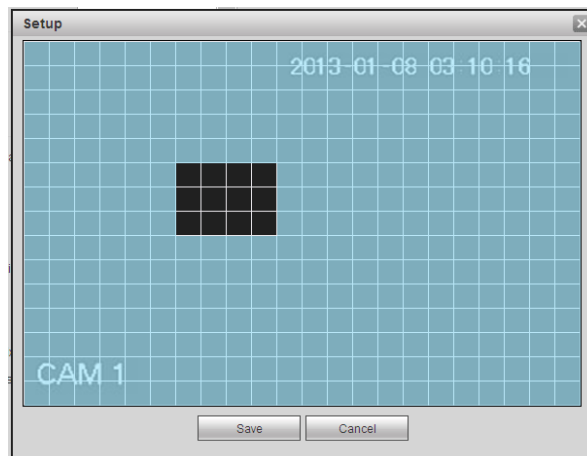

Figure 5-37

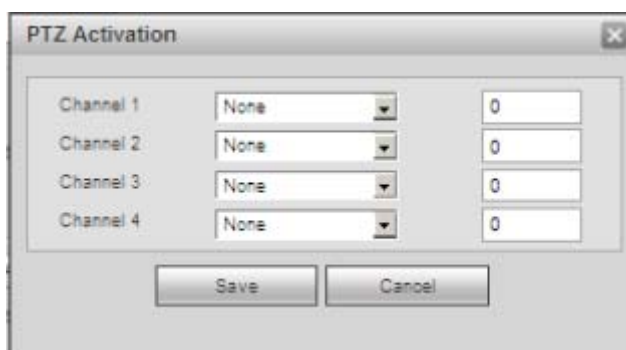

Figure 5-38

Please refer to the following sheet for detailed information.

| Parameter      | Function  |
|----------------|---|
| Enable         | You need to check the box to enable motion detection function. Please select a channel from the dropdown list.  |
| Period         | Motion detection function becomes activated in the specified periods. See Figure 5-36.<br>There are six periods in one day. Please draw a circle to enable corresponding period.<br>Click OK button, system goes back to motion detection interface, please click save button to exit.  |
| Anti-dither    | System only memorizes one event during the anti-dither period. The value ranges from 5s to 600s.  |
| Sensitivity    | There are six levels. The sixth level has the highest sensitivity.  |
| Region         | There are six levels. The sixth level has the highest sensitivity.<br>Region: If you select motion detection type, you can click this button to set motion detection zone. The interface is shown as in Figure 5-37. There are PAL 22X18/NTSC 22X15 zones. Right click mouse you can go to full-screen display mode. Do remember clicking OK button to save your motion detection zone setup. |
| Record channel | System auto activates motion detection channel(s) to record once an alarm occurs. Please note you need to set motion detect record period and go to Storage-> Schedule to set current channel as schedule record.   |
| Record Delay   | System can delay the record for specified time after alarm ended. The value ranges from 10s to 300s.  |
| Alarm out      | Enable alarm activation function. You need to select alarm output port so that system can activate corresponding alarm device when an alarm occurs.   |
| Latch          | System can delay the alarm output for specified time after an alarm ended. The value ranges from 1s to 300s.  |
| Show message   | System can pop up a message to alarm you in the local host screen if you enabled this function.   |
| Buzzer         | Check the box here to enable this function. The buzzer beeps when an alarm occurs.  |

| Parameter      | Function  |
|----------------|---|
| Alarm upload   | System can upload the alarm signal to the centre (Including alarm centre).  |
| Message        | When 3G network connection is OK, system can send out a message when motion detect occurs.  |
| Send Email     | If you enabled this function, System can send out an email to alert you when an alarm occurs.   |
| Tour           | You need to check the box here to enable this function. System begins 1-window or multiple-window tour display among the channel(s) you set to record when an alarm occurs.<br>Please go to chapter5.8.5.3.3 to set tour interval and tour mode.  |
| PTZ Activation | Here you can set PTZ movement when alarm occurs. Such as go to preset X. See Figure 5-38.   |
| Video Matrix   | This function is for motion detect only. Check the box here to enable video matrix function. Right now system supports one-channel tour function. System takes “first come and first serve” principle to deal with the activated tour. System will process the new tour when a new alarm occurs after previous alarm ended. Otherwise it restores the previous output status before the alarm activation. |

#### 5.8.3.1.2 Video Loss

The video loss interface is shown as in Figure 5-39.

After analysis video, system can generate a video loss alarm when the detected moving signal reached the sensitivity you set here.

Please note video loss does not support anti-dither, sensitivity, region setup. For rest setups, please refer to chapter 5.8.3.1.1 motion detect for detailed information.

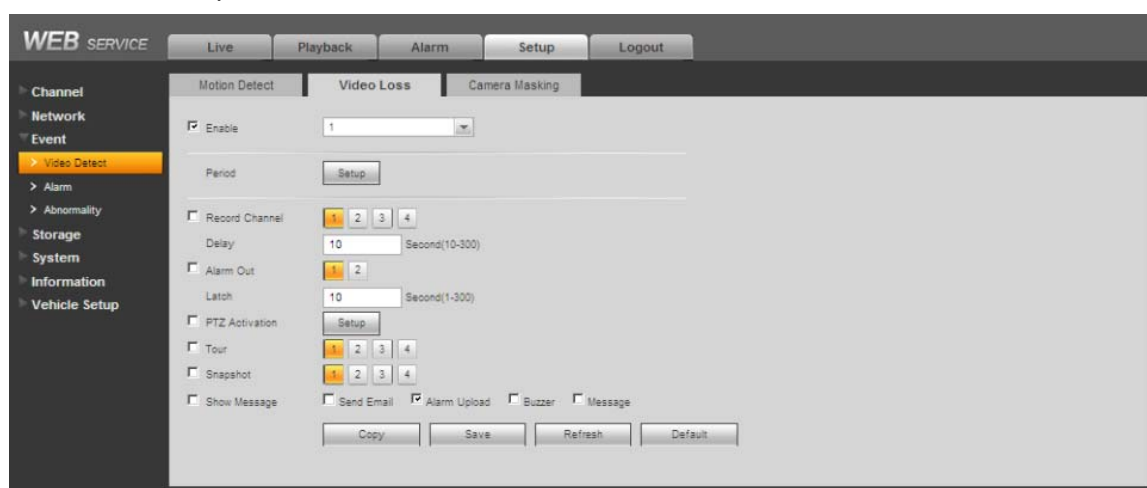

Figure 5-39

#### 5.8.3.1.3 Camera Masking

The camera masking interface is shown as in Figure 5-40.

After analysis video, system can generate a camera masking alarm when the detected moving signal reached the sensitivity you set here.

For detailed setups, please refer to chapter 5.8.3.1.1 motion detect for detailed information.

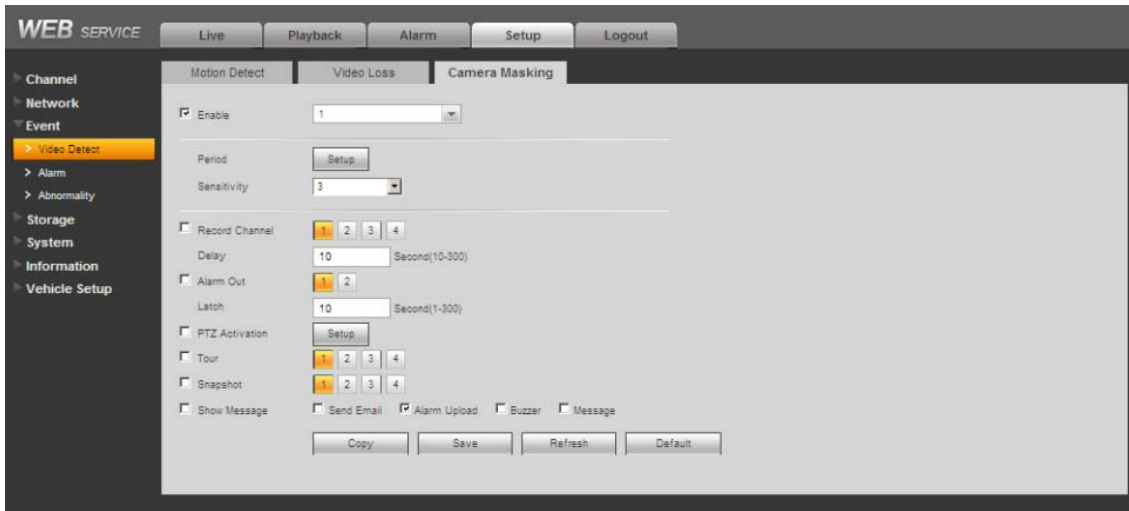

Figure 5-40

### 5.8.3.2 Alarm

Before operation, please make sure you have properly connected alarm devices such as buzzer. The input mode includes local alarm and network alarm.

#### 5.8.3.2.1 Local Alarm

The local alarm interface is shown as in Figure 5-41.

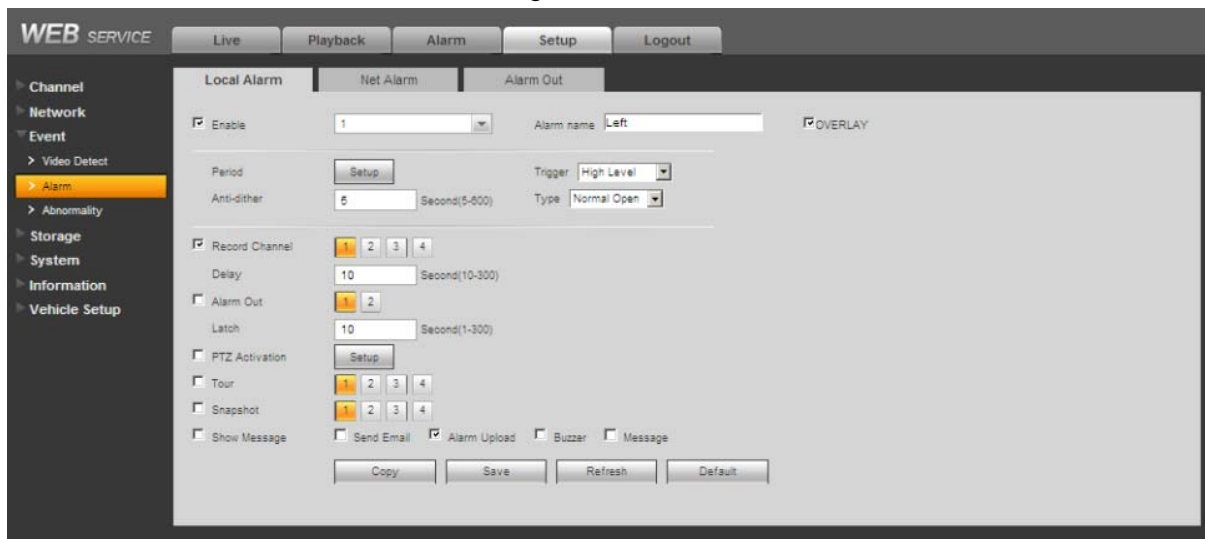

Figure 5-41

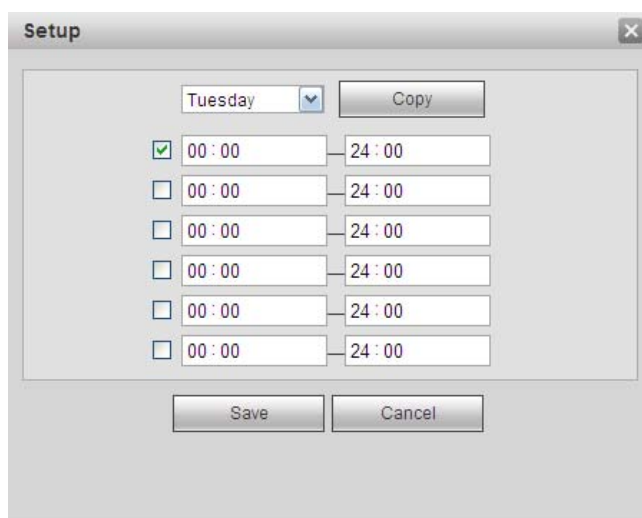

Figure 5-42

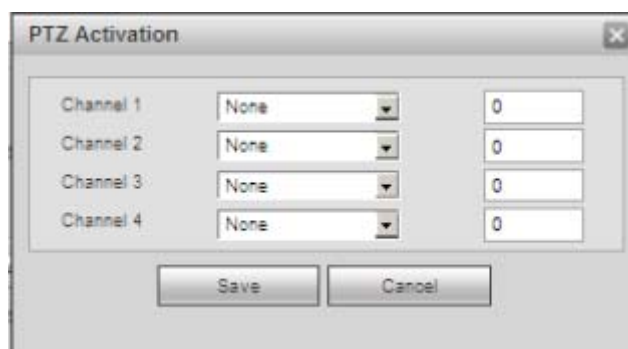

Figure 5-43

Please refer to the following sheet for detailed information.

| Parameter      | Function   |
|----------------|--|
| Enable         | You need to check the box to enable this function.<br>Please select a channel from the dropdown list.  |
| Period         | This function becomes activated in the specified periods.<br>There are six periods in one day. Please draw a circle to enable corresponding period.<br>Select date. If you do not select, current setup applies to today only. You can select all week column to apply to the whole week.<br>Click OK button, system goes back to local alarm interface, please click save button to exit. |
| Anti-dither    | System only memorizes one event during the anti-dither period. The value ranges from 5s to 600s.   |
| Sensor type    | There are two options: NO/NC.  |
| Record channel | System auto activates motion detection channel(s) to record once an alarm occurs. Please note you need to set alarm record period and go to Storage-> Schedule to set current channel as schedule record.  |

| Parameter      | Function   |
|----------------|--|
| Record Delay   | System can delay the record for specified time after alarm ended. The value ranges from 10s to 300s.   |
| Alarm out      | Enable alarm activation function. You need to select alarm output port so that system can activate corresponding alarm device when an alarm occurs.  |
| Latch          | System can delay the alarm output for specified time after an alarm ended. The value ranges from 1s to 300s.   |
| Show message   | System can pop up a message to alarm you in the local host screen if you enabled this function.  |
| Buzzer         | Check the box here to enable this function. The buzzer beeps when an alarm occurs.   |
| Alarm upload   | System can upload the alarm signal to the centre (Including alarm centre.  |
| Send Email     | If you enabled this function, System can send out an email to alert you when an alarm occurs.  |
| Tour           | You need to check the box here to enable this function. System begins 1-window or multiple-window tour display among the channel(s) you set to record when an alarm occurs.<br><br>Please go to chapter5.8.5.3.3 to set tour interval and tour mode. |
| PTZ Activation | Here you can set PTZ movement when alarm occurs. Such as go to preset X.   |

### 5.8.3.2.2 Net Alarm

The network alarm interface is shown as in Figure 5-44.

Network alarm refers to the alarm signal from the network. System does not support anti-dither and sensor type setup. For reset setups, please refer to chapter 5.8.3.2.1.



Figure 5-44

### 5.8.3.2.3 Alarm Out

Here you can set alarm output channel mode: schedule/manual/stop. See Figure 5-45.

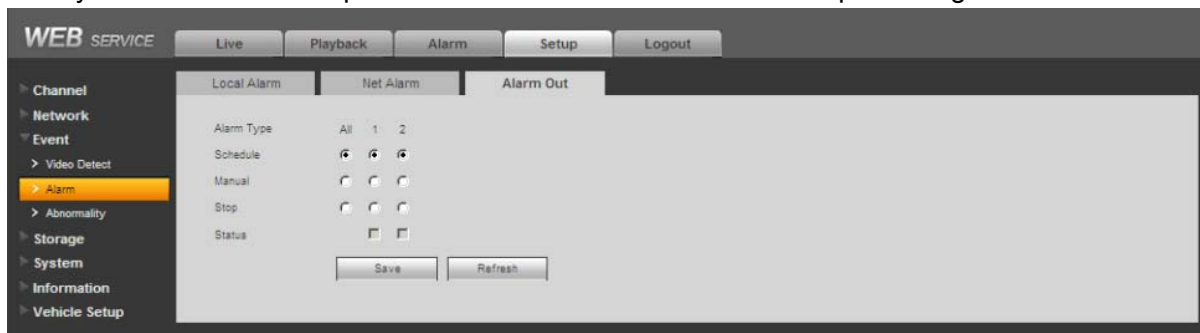

Figure 5-45

### 5.8.3.3 Abnormality

It includes six statuses: No disk, disk error, disk no space, battery low, temperature high. See Figure 5-46 through Figure 5-50.



Figure 5-46



Figure 5-47

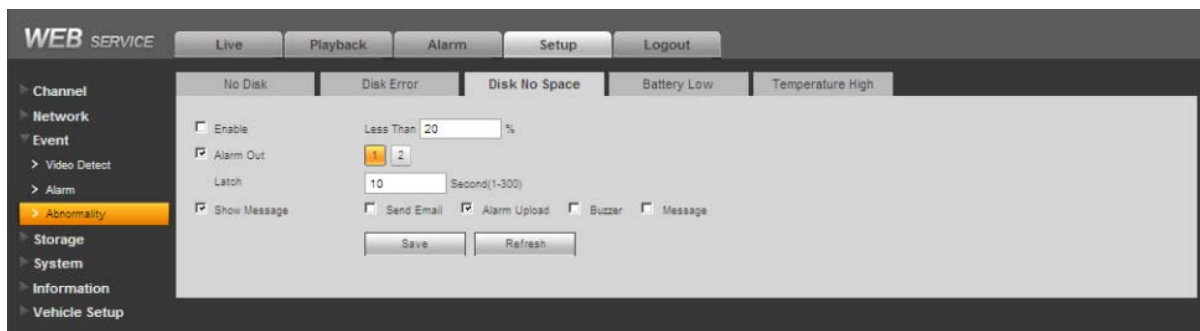

Figure 5-48

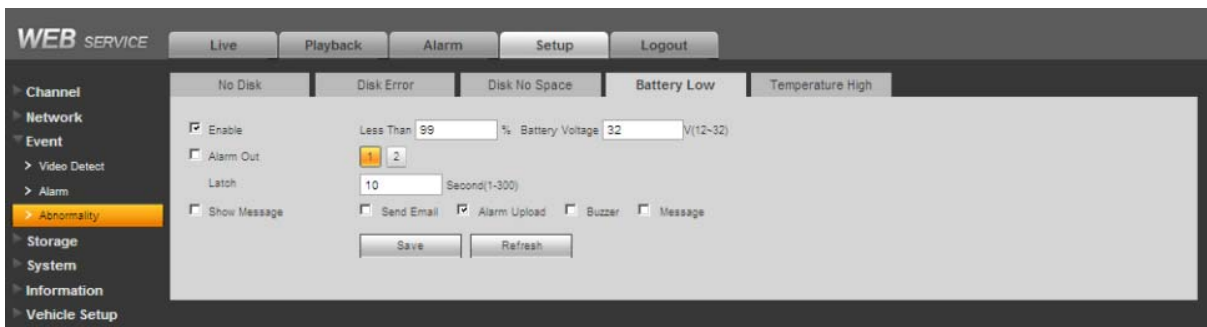

Figure 5-49

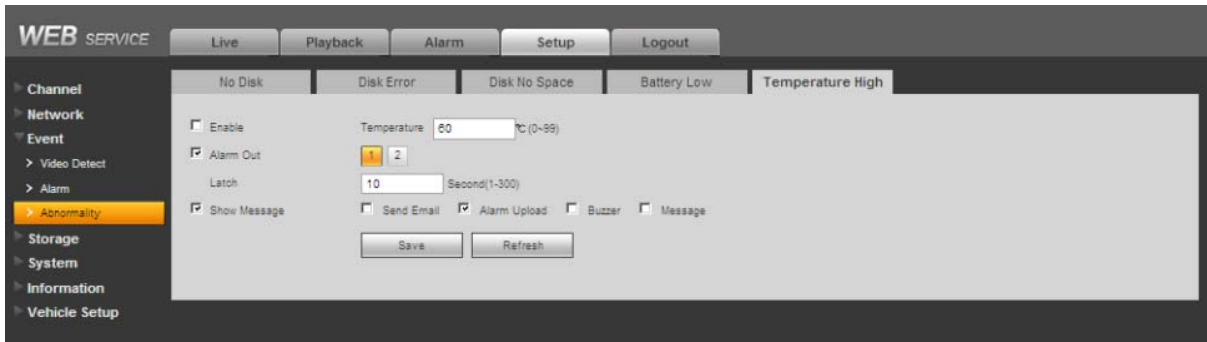

Figure 5-50

Please refer to the following sheet for detailed information.

| Parameter    | Function   |
|--------------|--|
| Event Type   | The abnormal events include: No disk, disk error, disk no space, battery low, temperature high.<br>You can set one or more items here. |
| Enable       | Check the box here to enable selected function.  |
| Alarm Out    | Please select corresponding alarm output channel when an alarm occurs. You need to check the box to enable this function.              |
| Latch        | The alarm output can delay for the specified time after an alarm stops. The value ranges from 1s to 300s.                              |
| Show message | System can pop up a message to alarm you in the local host screen if you enabled this function.  |
| Alarm upload | System can upload the alarm signal to the centre (Including alarm centre).   |
| Send Email   | If you enabled this function, System can send out an email to alert you when an alarm occurs.  |
| Buzzer       | Check the box here to enable this function. The buzzer beeps when an alarm occurs.   |

## 5.8.4 Storage

### 5.8.4.1 Schedule

In this interfaces, you can add or remove the schedule record setup. See Figure 5-51.

There are three record modes: general (auto), motion detect and alarm. There are six periods in

one day. Please make sure you have enabled the corresponding record mode in the Setup->Storage->Conditions.

You can view the current time period setup from the color bar.

- Green color stands for the general record/snapshot.
- Yellow color stands for the motion detect record/snapshot..
- Red color stands for the alarm record/snapshot.

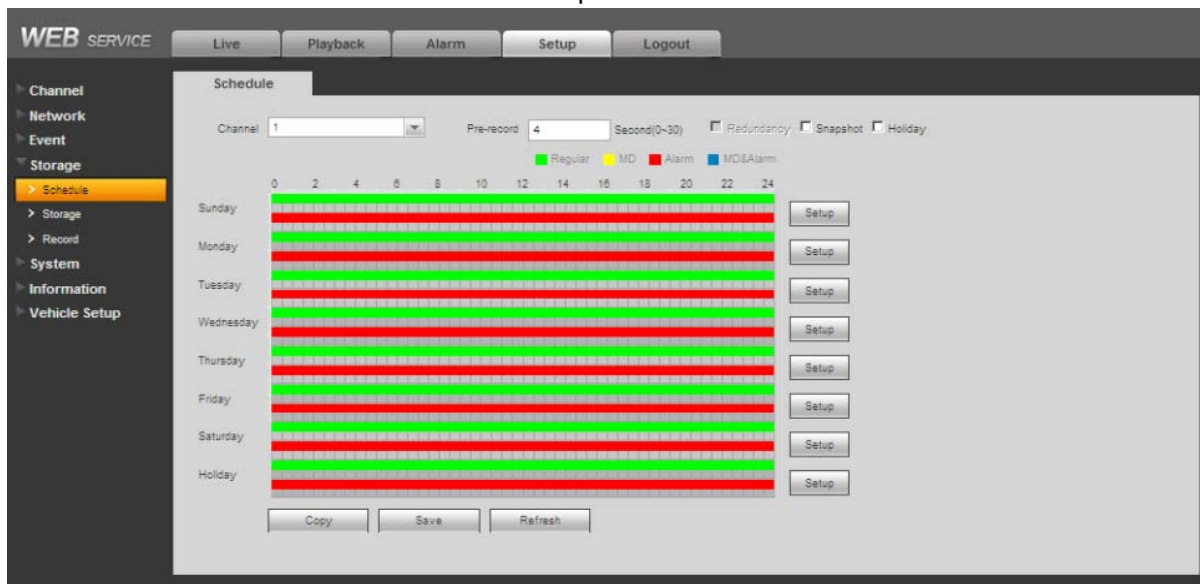

Figure 5-51

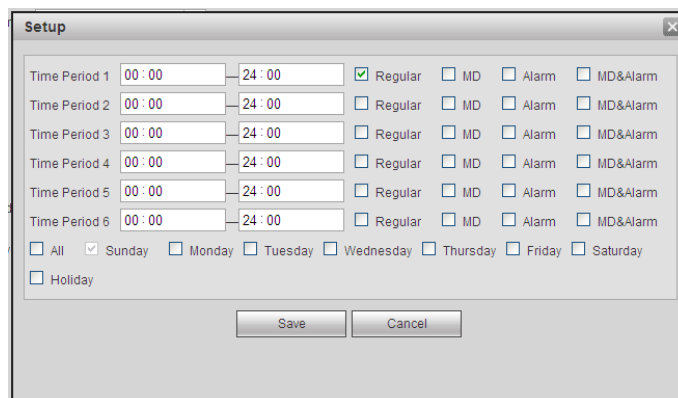

Figure 5-52

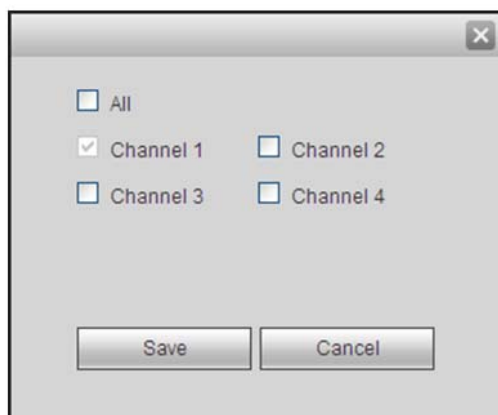

Figure 5-53

Please refer to the following sheet for detailed information.

| Parameter                  | Function  |
|----------------------------|---|
| Channel                    | Please select a channel from the dropdown list.   |
| Pre-record                 | Please input pre-record time here. The value ranges from 0 to 30.   |
| Redundancy                 | Check the box here to enable redundancy function. <b>Please note this function is null if there is only one HDD.</b>  |
| Snapshot                   | Check the box here to enable snapshot function.   |
| Holiday                    | Check the box here to enable holiday function.  |
| Setup (Sunday to Saturday) | Click the Setup button, you can set record period. See Figure 5-52. There are six periods in one day. If you do not check the date at the bottom of the interface, current setup is for today only. Please click Save button and then exit.   |
| Setup (Holiday)            | Click the Setup button, you can set record period. See Figure 5-52. There are six periods in one day. If you check Holiday box, current channel shall record as your holiday setup here.  |
| Copy                       | Copy function allows you to copy one channel setup to another. After setting in channel, click Copy button, you can go to interface Figure 5-53. You can see current channel name is grey such as channel 1. Now you can select the channel you want to paste such as channel 2. If you want to save current setup of channel 1 to all channels, you can click the first box "ALL". Click the OK button to save current copy setup. Click the OK button in the Encode interface, the copy function succeeded. |

## 5.8.4.2 Storage

### 5.8.4.2.1 Local Storage

The local interface is shown as in Figure 5-54. Here you can see storage device information. You can also operate the read-only, write-only, hot swap and format operation.

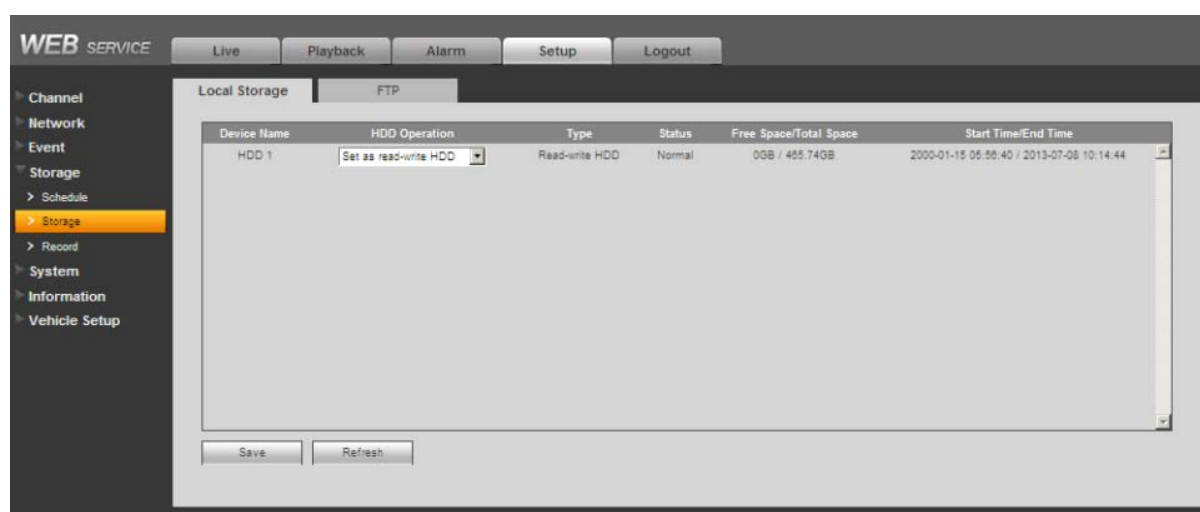

Figure 5-54

### 5.8.4.2.2 FTP

The FTP interface is shown as in Figure 5-55.

The FTP function is on if you check the Enable box here.

When network is offline or malfunction, system can save record or picture to HDD.

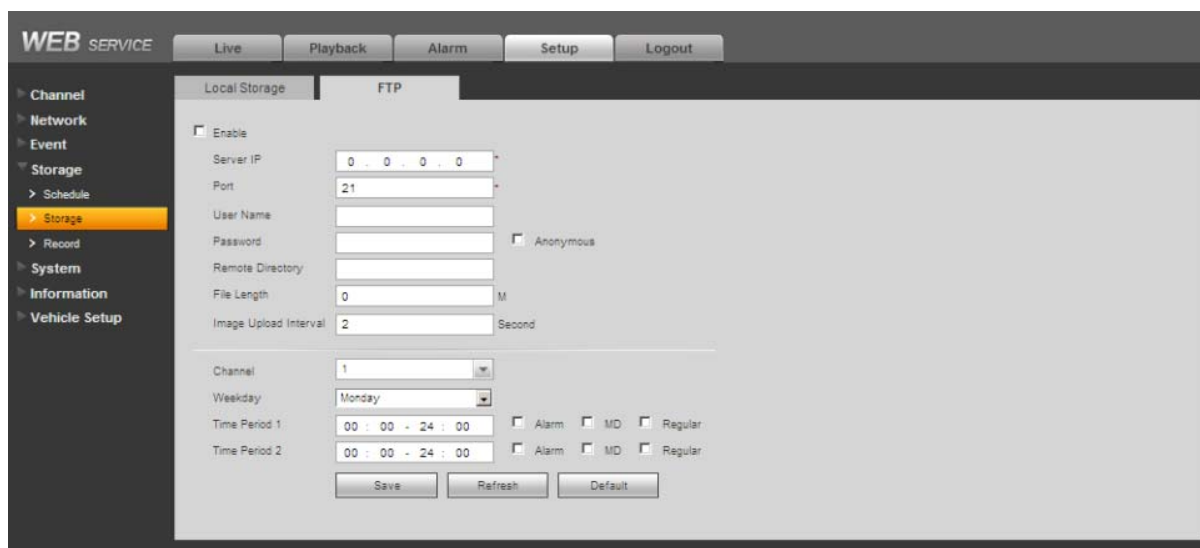

Figure 5-55

#### 5.8.4.3 Record control

The record control interface is shown as in Figure 5-56.



Figure 5-56

Please refer to the following sheet for detailed information.

| Parameter | Function  |
|-----------|---|
| Channel   | Here you can view channel number.<br>The number displayed here is the max channel amount of your device.    |
| Status    | There are three statuses: schedule, manual and stop.  |
| Schedule  | System enables auto record function as you set in record schedule setup (general, motion detect and alarm). |

|                    |   |
|--------------------|---|
| Manual             | It has the highest priority.<br>Enable corresponding channel to record no matter what period applied in the record setup. |
| Stop               | Stop current channel record no matter what period applied in the record setup.  |
| Start all/stop all | Check the corresponding All button, you can enable or disable all channels record.  |

## 5.8.5 System

### 5.8.5.1 General

The general interface includes General, date/time and holiday setup.

#### 5.8.5.1.1 General

The general interface is shown as in Figure 5-57.

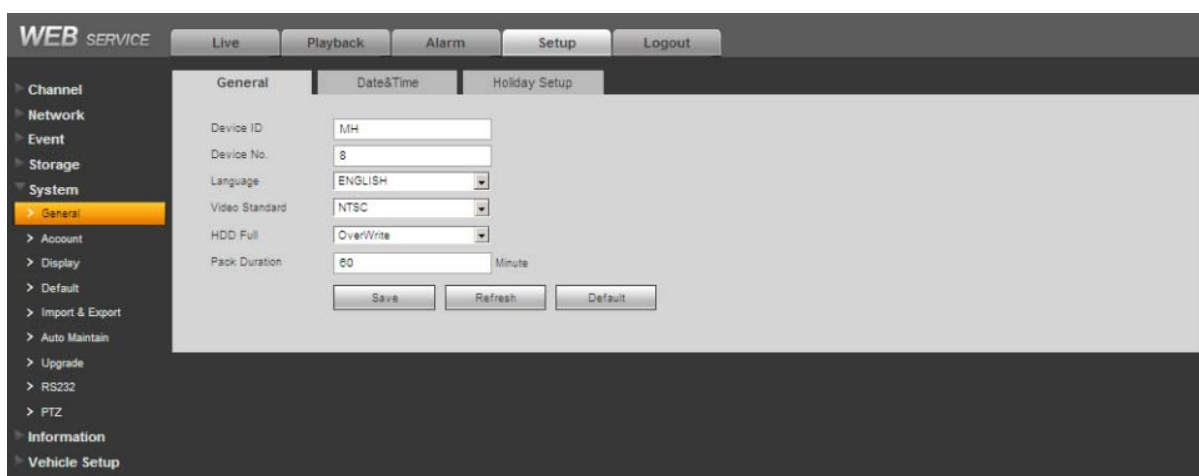

Figure 5-57

Please refer to the following sheet for detailed information.

| Parameter      | Function   |
|----------------|--|
| Device ID      | It is to set device name.  |
| Device No.     | It is device channel number.   |
| Language       | You can select the language from the dropdown list.<br><b>Please note the device needs to reboot to get the modification activated.</b>  |
| Video Standard | This is to display video standard such as PAL.   |
| HDD full       | Here is for you to select working mode when hard disk is full. There are two options: stop recording or rewrite. If current working HDD is overwritten or the current HDD is full while the next HDD is no empty, then system stops recording, If the current HDD is full and then next HDD is not empty, then system overwrites the previous files. |
| Pack duration  | Here is for you to specify record duration. The value ranges from 1 to 120 minutes. Default value is 60 minutes.   |

#### 5.8.5.1.2 Date and time

The date and time interface is shown as in Figure 5-58

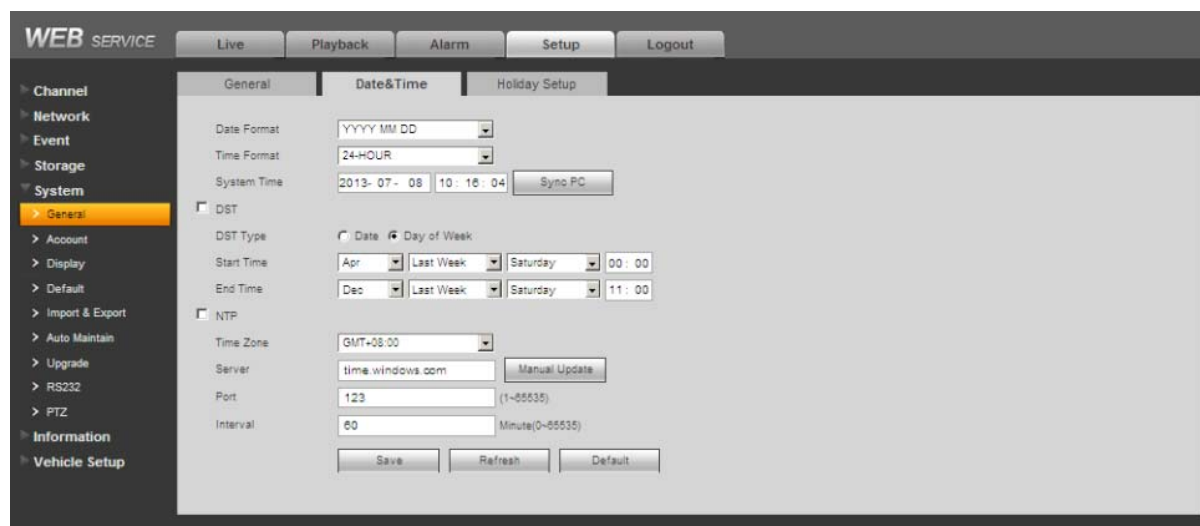

Figure 5-58

Please refer to the following sheet for detailed information.

| Parameter   | Function  |
|-------------|---|
| Date format | Here you can select date format from the dropdown list.   |
| Time Format | There are two options: 24-H and 12-H.   |
| Time zone   | The time zone of the device.  |
| System time | It is to set system time. It becomes valid after you set.   |
| Sync PC     | You can click this button to save the system time as your PC current time.  |
| DST         | Here you can set day night save time begin time and end time. You can set according to the date format or according to the week format. |
| NTP         | You can check the box to enable NTP function.   |
| NTP server  | You can set the time server address.  |
| Port        | It is to set the time server port.  |
| Interval    | It is to set the sync periods between the device and the time server.   |

#### 5.8.5.1.3 Holiday Setup

Holiday setup interface is shown as in Figure 5-59.

Here you can check the box here to enable this function and then set.

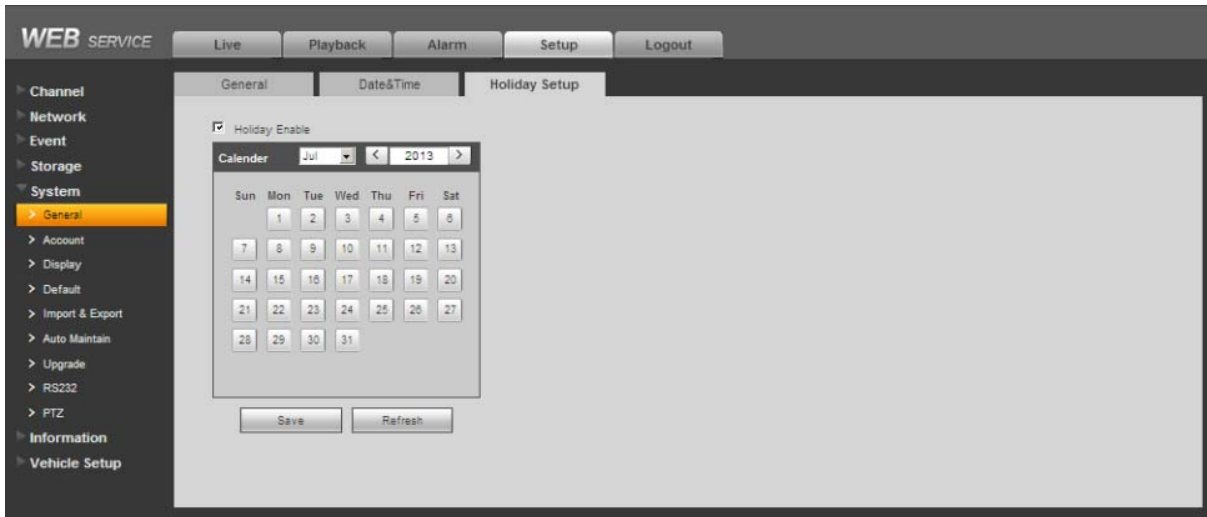

Figure 5-59

### 5.8.5.2 Account

#### Note:

- For the character in the following user name or the user group name, system max supports 6-digits. The space in the front or at the end of the string is null. The valid string includes: character, number, and underline.
- The user amount is 20 and the group amount is 8 when the device is shipped out of the factory. The factory default setup includes two levels: user and admin. You can set the corresponding group and then set the rights for the respective user in the specified groups.
- User management adopts group/user modes. The user name and the group name shall be unique. One user shall be included in only one group.

#### 5.8.5.2.1 User name

In this interface you can add/remove user and modify user name. See Figure 5-60.

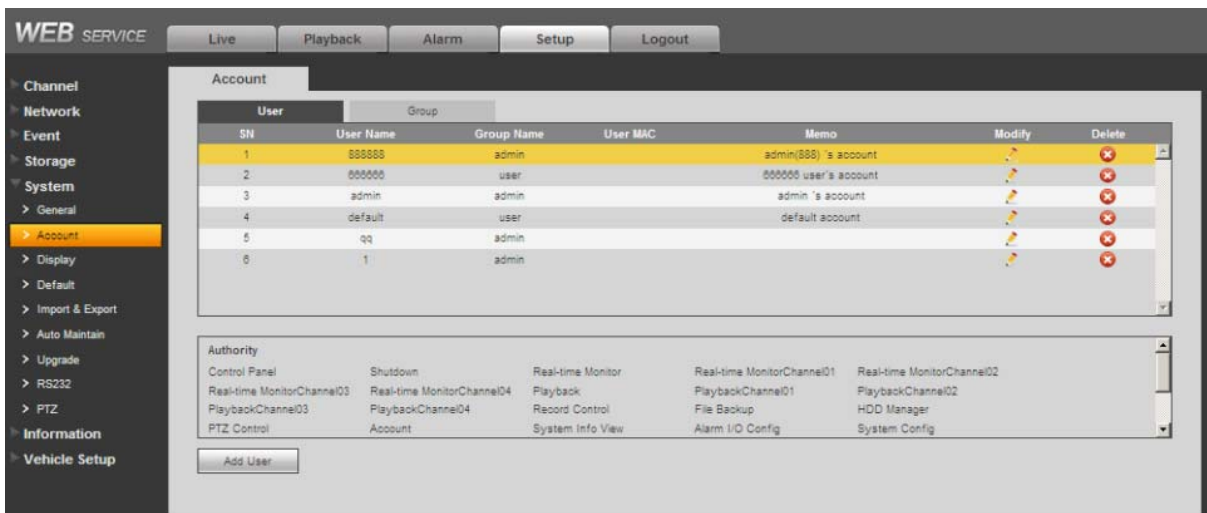

Figure 5-60

**Add user:** It is to add a name to group and set the user rights. See Figure 5-61.

There are four default users: admin/888888/666666 and hidden user “default”. Except user 6666, other users have administrator right. The user 666666 can only have the monitor rights,. Hidden user “default” is for system interior use only and can not be deleted. When there is no

login user, hidden user “default” automatically login. You can set some rights such as monitor for this user so that you can view some channel view without login.

Here you can input the user name and password and then select one group for current user.

Please note the user rights shall not exceed the group right setup.

For convenient setup, please make sure the general user has the lower rights setup than the admin.

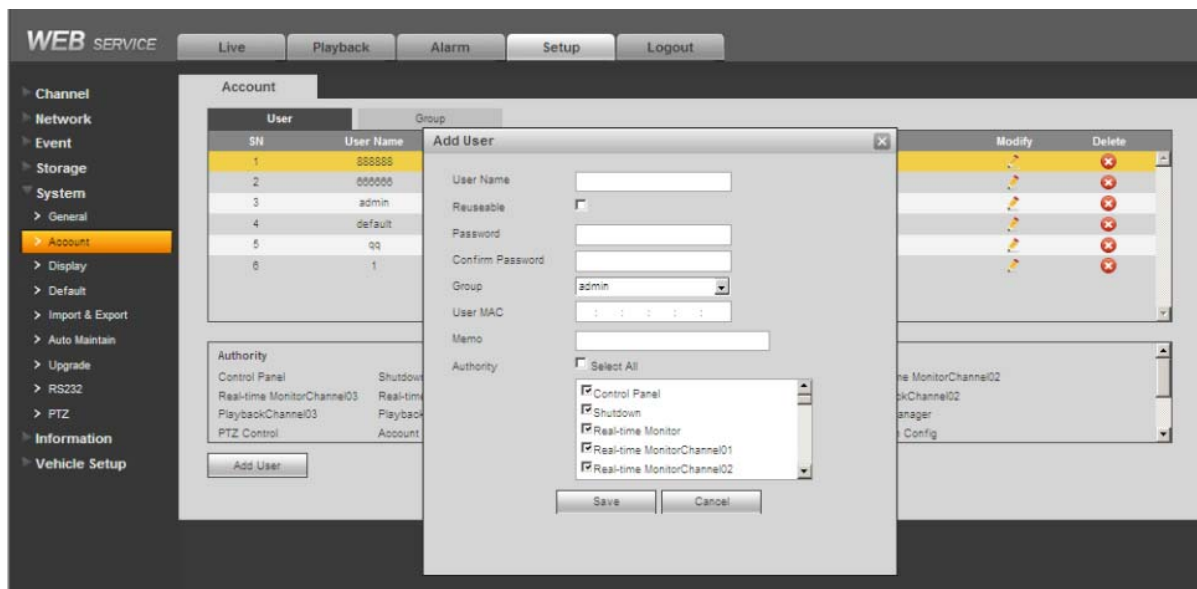

Figure 5-61

### Modify user

It is to modify the user property, belonging group, password and rights. See Figure 5-62.

### Modify password

It is to modify the user password. You need to input the old password and then input the new password twice to confirm the new setup. Please click the OK button to save.

Please note, the password ranges from 1-digit to 6-digit. It shall include the number only. For the user of the account rights, he can modify the password of other users.

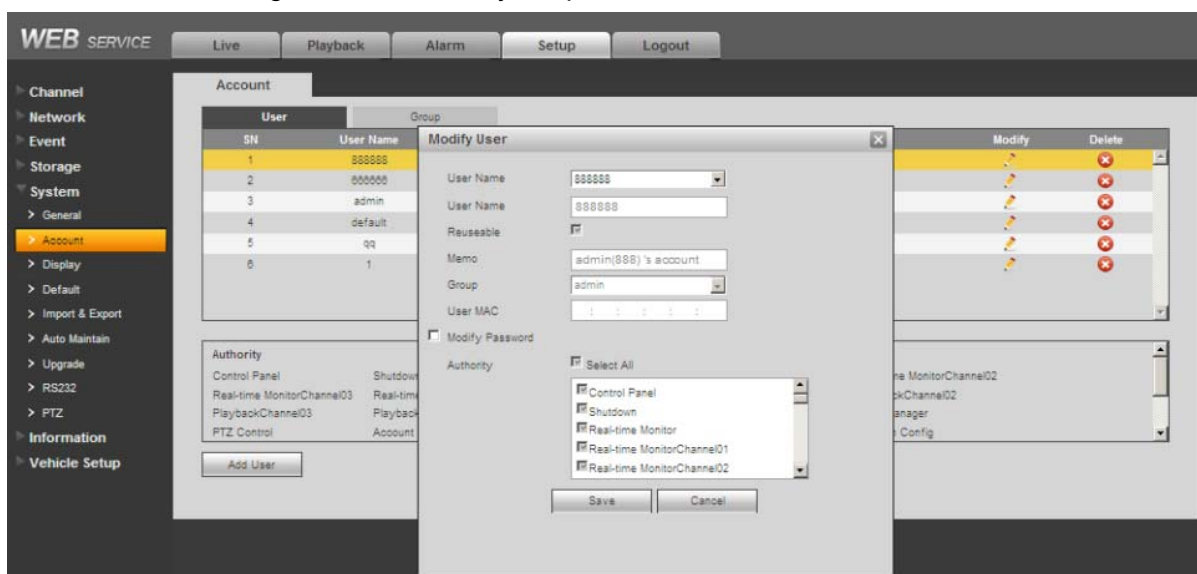

Figure 5-62

### 5.8.5.2.2 Group

The group management interface can add/remove group, modify group password and etc. The interface is shown as in Figure 5-63.

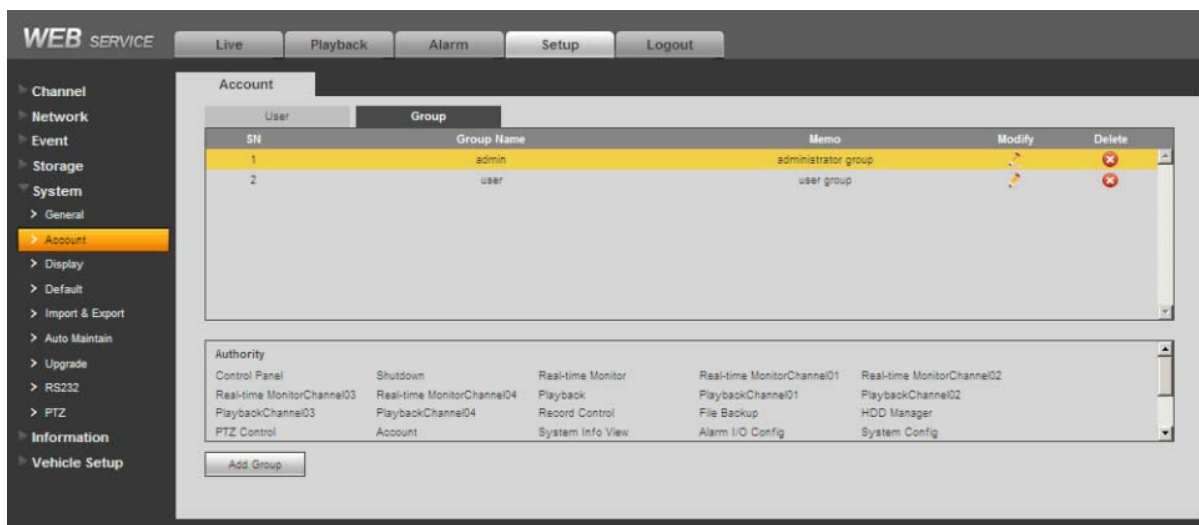

Figure 5-63

**Add group:** It is to add group and set its corresponding rights. See Figure 5-64.

Please input the group name and then check the box to select the corresponding rights. It includes: shutdown/reboot device, live view, record control, PTZ control and etc.

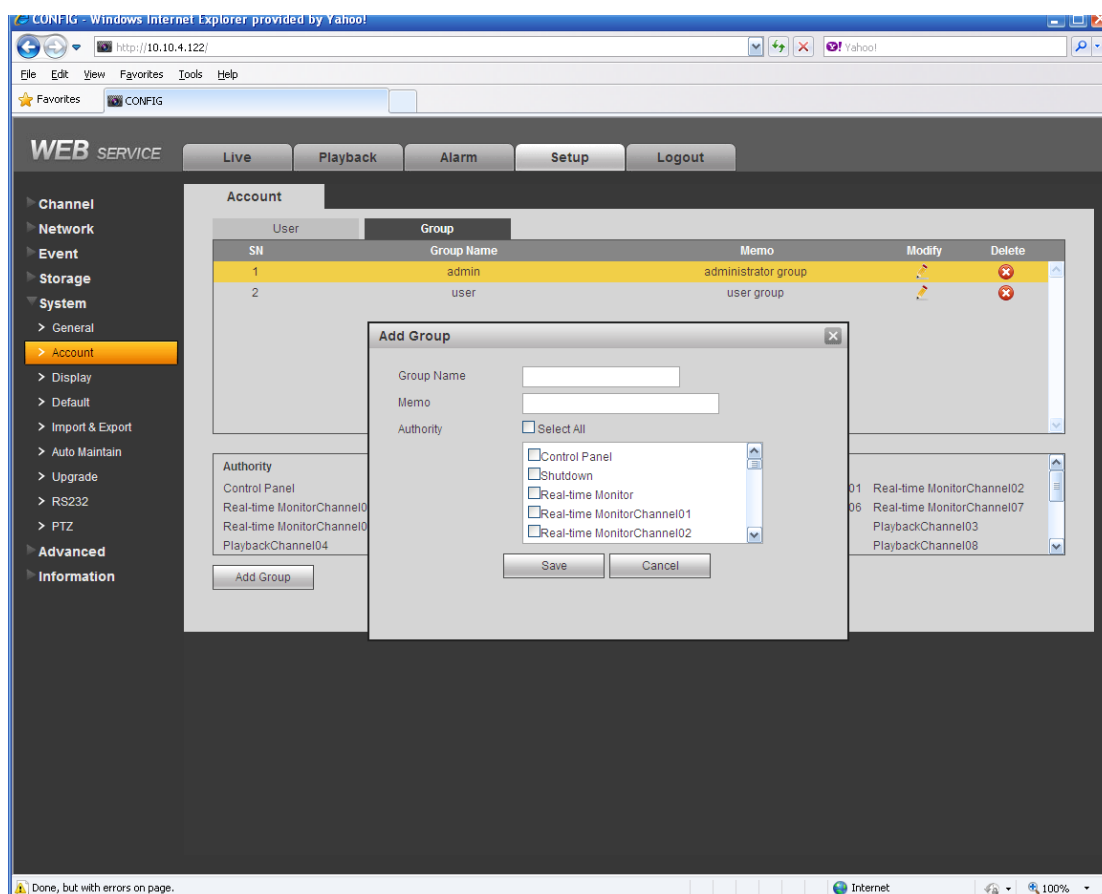

Figure 5-64

### Modify group

Click the modify group button, you can see an interface is shown as in Figure 5-65. Here you can modify group information such as remarks and rights.

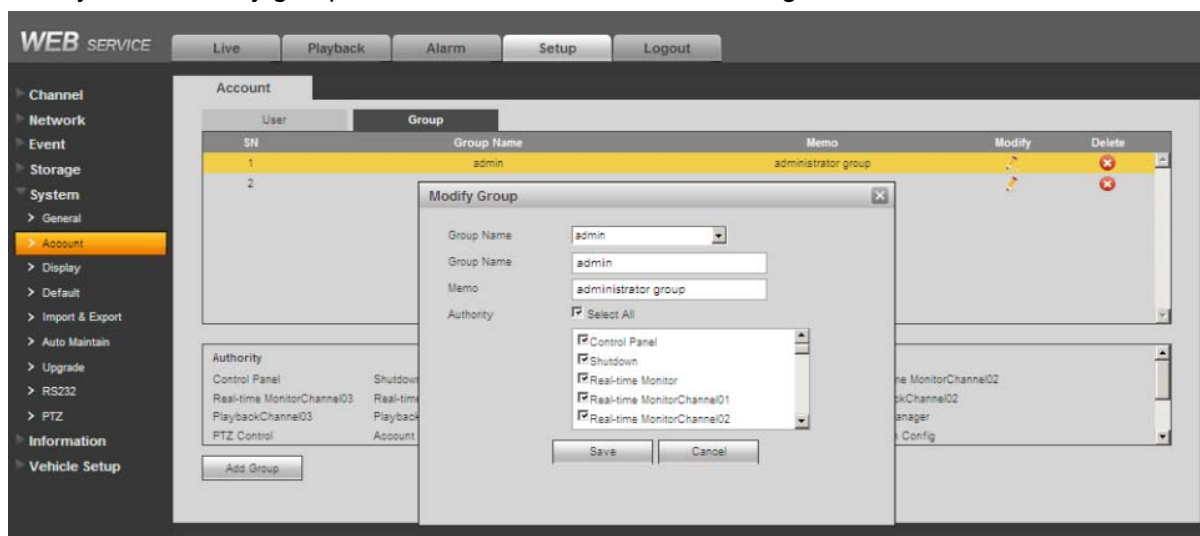

Figure 5-65

### 5.8.5.3 Display

Display interface includes GUI, TV adjust, and Tour.

#### 5.8.5.3.1 GUI

Here you can set background color and transparency level. See Figure 5-66.

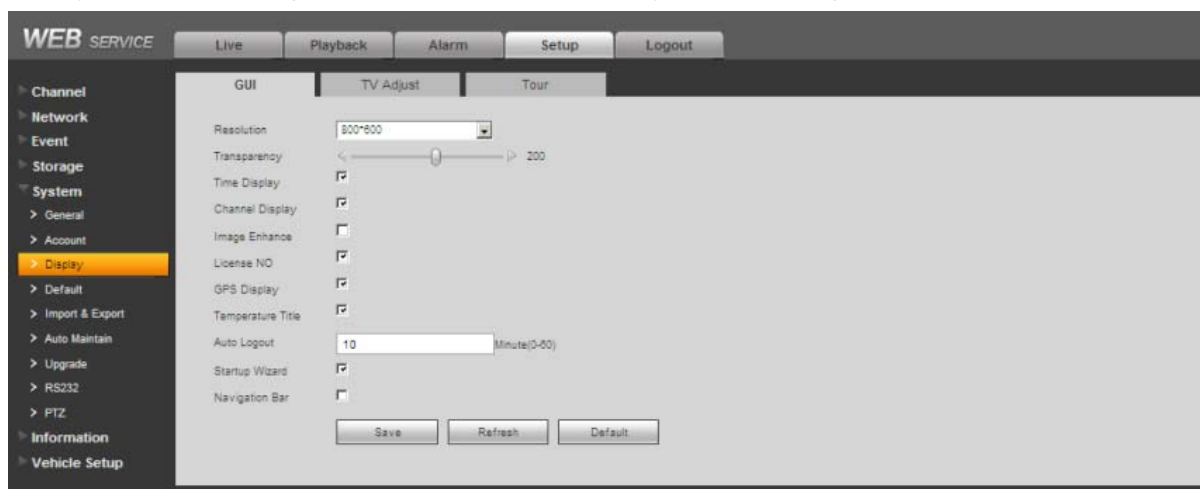

Figure 5-66

Please refer to the following sheet for detailed information.

| Parameter                | Function  |
|--------------------------|---|
| Resolution               | There are five options: 1920 × 1080, 1280 × 1024, 1280 × 720, 1024 × 768, 800 × 600(Default). Please note the system needs to reboot to activate current setup. |
| Transparency             | Here is for you to adjust transparency. The value ranges from 128 to 255.   |
| Time title/channel title | Check the box here, you can view system time and channel number on the monitor video.   |
| Image                    | Check the box; you can optimize the margin of the preview video.  |

|                |  |
|----------------|--|
| enhance        |  |
| Auto logout    | Here is for you to set auto logout interval once login user remains inactive for a specified time.   |
| Startup wizard | Check the box here, system goes to the startup wizard when the device boots up the next time. Otherwise, it goes to the system login interface directly. |
| Navigation bar | Check the box here, system displays the navigation bar on the interface.   |

### 5.8.5.3.2 TV Adjust

It is to set TV output region. See Figure 5-67.

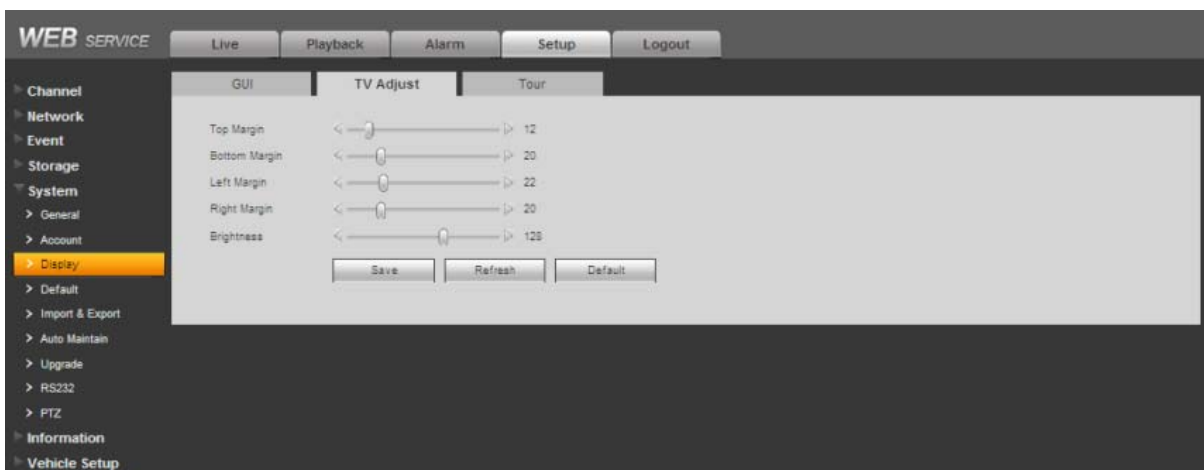

Figure 5-67

### 5.8.5.3.3 Tour

The tour interface is shown as in Figure 5-68. Here you can set tour interval, split mode, motion detect tour and alarm tour mode.

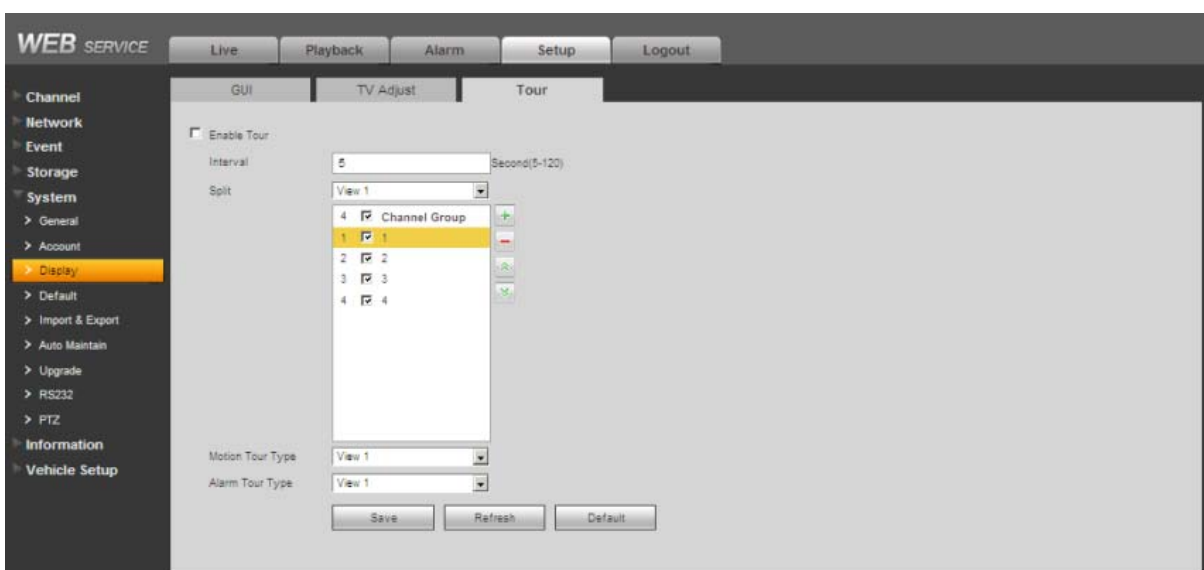

Figure 5-68

Please refer to the following sheet for detailed information.

| Parameter              | Function  |
|------------------------|---|
| Enable tour            | Check the box here to enable tour function.   |
| Interval               | Here is for you to adjust transparency. The value ranges from 5 to 120s. The default setup is 5s. |
| Split                  | Here you can set window mode and channel group.   |
| Motion tour/Alarm tour | Here you can set motion detect tour/alarm tour window mode. System supports 1-window.             |

#### 5.8.5.4 Default

The default setup interface is shown as in Figure 5-69.

Here you can select Channel/Network/Event/Storage/System. Or you can check the All box to select all items.

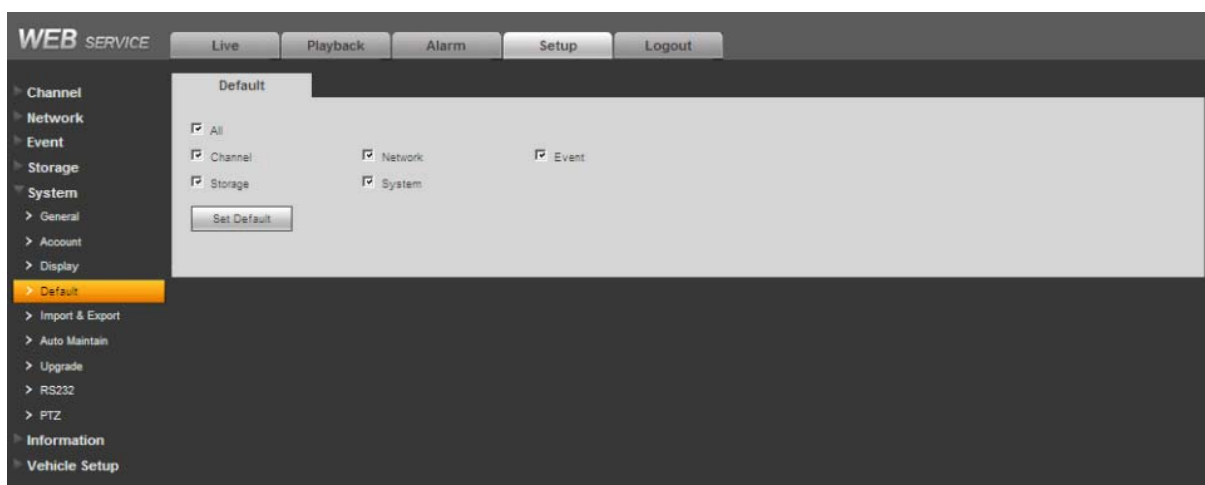

Figure 5-69

#### 5.8.5.5 Import/Export

The interface is shown as in Figure 5-70.

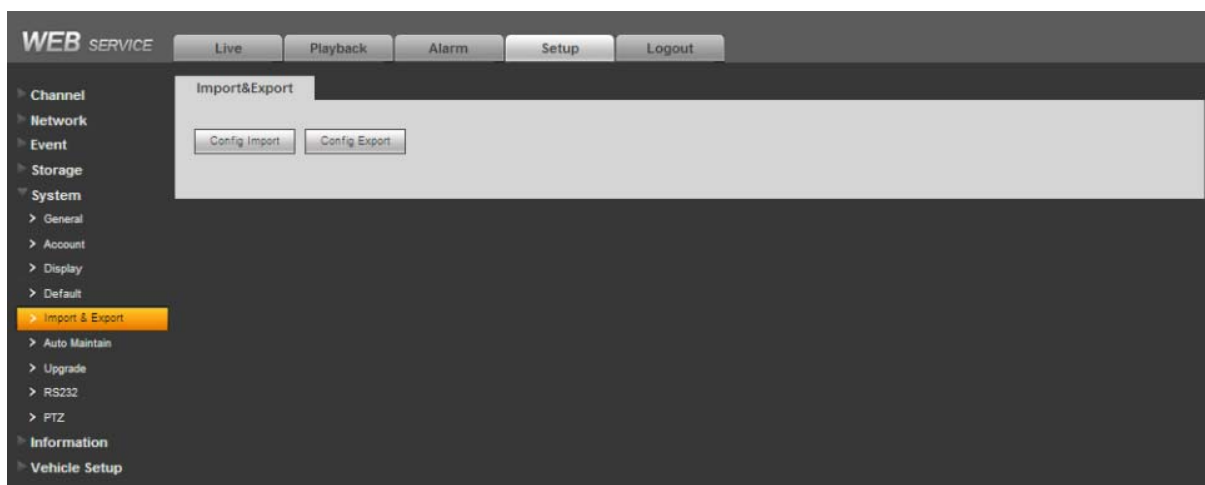

Figure 5-70

Please refer to the following sheet for detailed information.

| Parameter | Function  |
|-----------|---|
| Import    | It is to import the local setup files to the system.          |
| Export    | It is to export the corresponding WEB setup to your local PC. |

### 5.8.5.6 Auto Maintenance

The auto maintenance interface is shown as in Figure 5-71.

Here you can select auto reboot and auto delete old files interval from the dropdown list.

If you want to use the auto delete old files function, you need to set the file period.

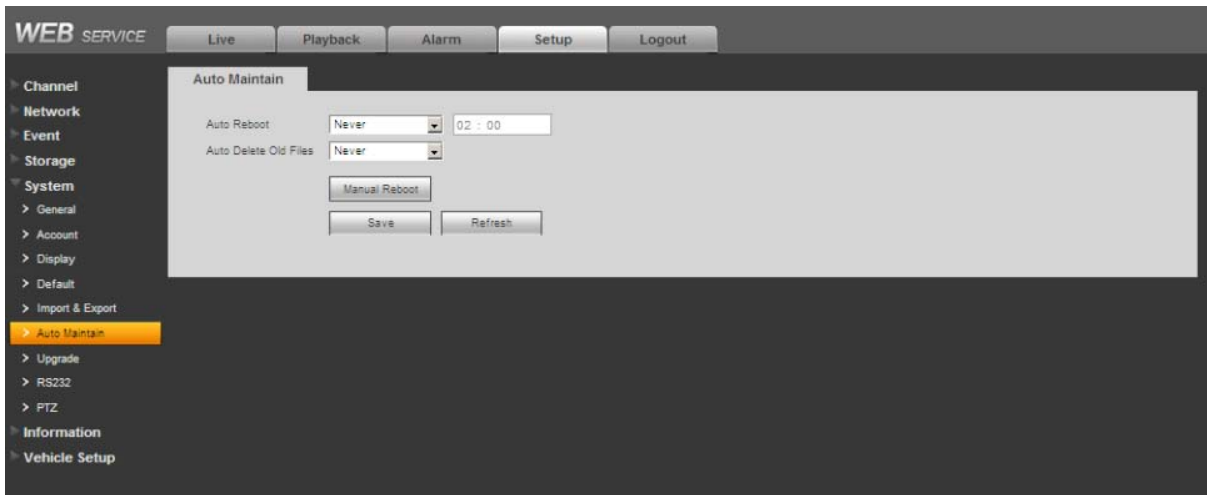

Figure 5-71

### 5.8.5.7 Upgrade

The upgrade interface is shown as in Figure 5-72.

Please select the upgrade file and then click the update button to begin update. Please note the file name shall be as \*.bin. During the upgrade process, do not unplug the power cable, network cable, or shutdown the device.

#### **Important**

**Improper upgrade program may result in device malfunction!**



Figure 5-72

### 5.8.5.8 RS232

The RS232 interface is shown as in Figure 5-73.

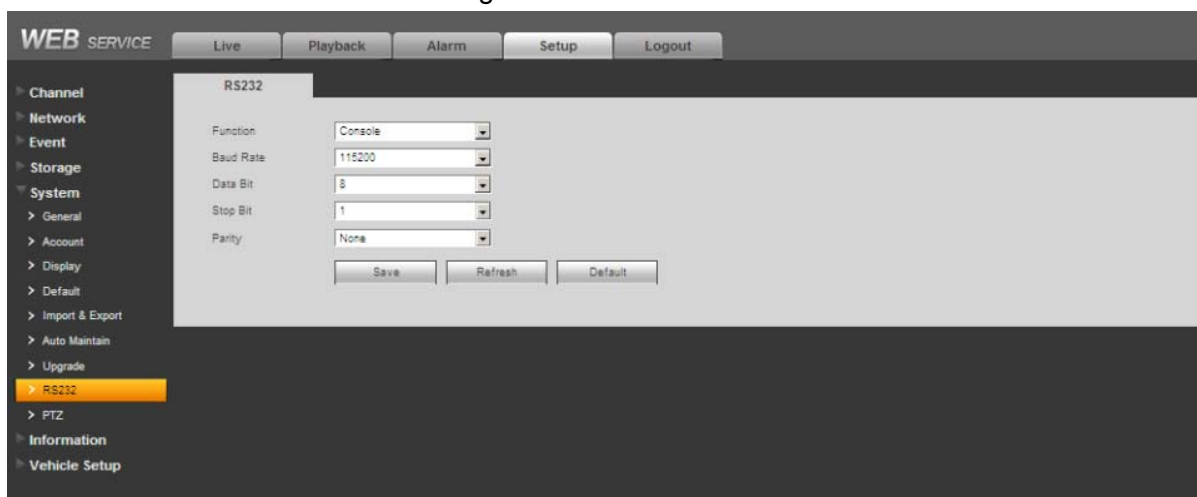

Figure 5-73

Please refer to the following sheet for detailed information.

| Parameter | Function  |
|-----------|---|
| Function  | Select the corresponding COM control protocol.<br>Default setup is console. |
| Baud Rate | Select the baud rate.<br>Default setup is 115200.                           |
| Data Bit  | The value ranges from 5 to 8.<br>Default setup is 8.                        |
| Stop bit  | There are two options: 1/2.<br>Default setup is 1.                          |
| Parity    | There are five options: none/odd/even/space/mark.<br>Default setup is none. |

### 5.8.5.9 PTZ

The PTZ interface is shown as in Figure 5-74.

Before setup, please check the following connections are right:

- PTZ and decoder connection is right. Decoder address setup is right.
- Decoder A (B) line connects with DVR A (B) line.

Click Save button after you complete setup, you can go back to the monitor interface to control speed dome.

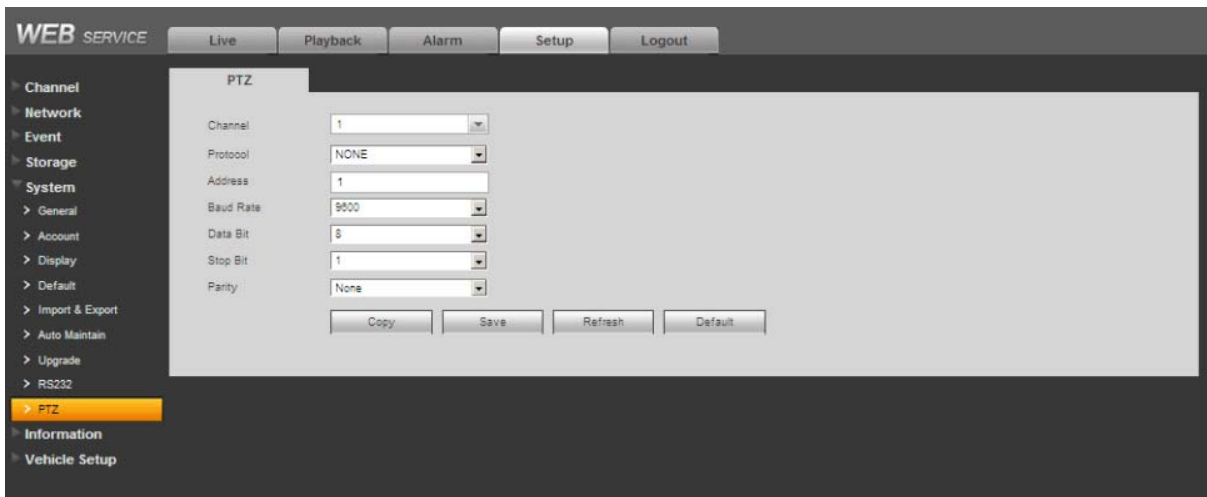

Figure 5-74

Please refer to the following sheet for detailed information.

| Parameter | Function  |
|-----------|---|
| Channel   | Select speed dome connected channel.  |
| Protocol  | Select the corresponding dome protocol such as PELCOD.  |
| Address   | Set corresponding dome address. Default value is 1. <b>Please note your setup here shall comply with your dome address; otherwise you can not control the speed dome.</b> |
| Baud Rate | Select the dome baud rate. Default setup is 9600.   |
| Data Bit  | Default setup is 8. Please set according to the speed dome dial switch setup.   |
| Stop bit  | Default setup is 1. Please set according to the speed dome dial switch setup.   |
| Parity    | Default setup is none. Please set according to the speed dome dial switch setup.  |

## 5.8.6 Information

### 5.8.6.1 Version

The version interface is shown as in Figure 5-75.

Here you can view system hardware features, software version, release date and etc. Please note the following information is for reference only.

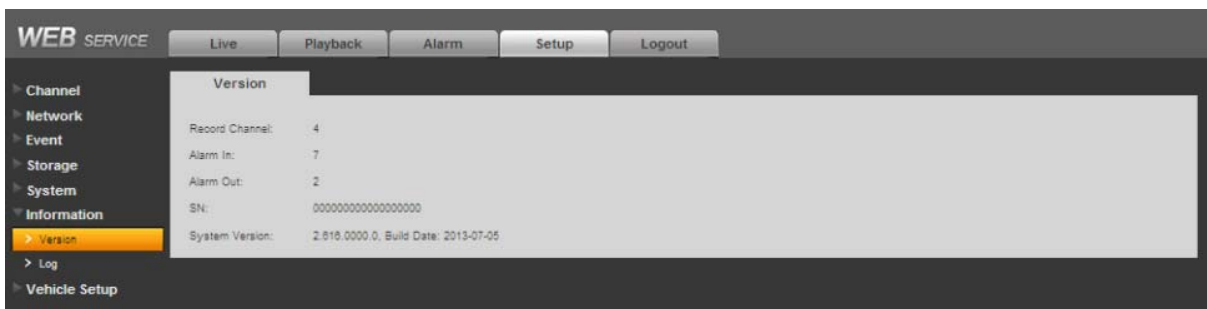

Figure 5-75

### 5.8.6.2 Log

Here you can view system log. See Figure 5-76.

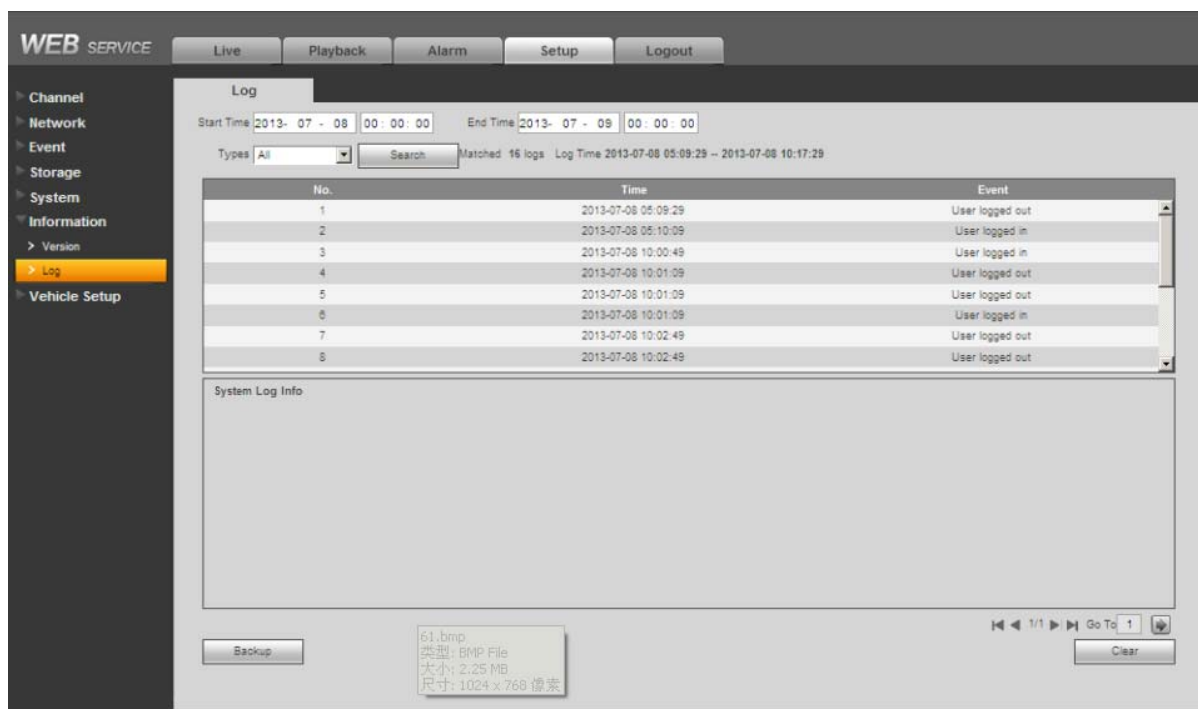

Figure 5-76

Please refer to the following sheet for log parameter information.

| Parameter            | Function   |
|----------------------|--|
| Type                 | Log types include: system operation, configuration operation, data operation, event operation, record operation, user management, log clear.                           |
| Start time           | Set the start time of the requested log.   |
| End time             | Set the end time of the requested log.   |
| Search               | You can select log type from the drop down list and then click search button to view the list.<br>You can click the stop button to terminate current search operation. |
| Detailed information | You can select one item to view the detailed information.  |
| Clear                | You can click this button to delete all displayed log files. Please note system does not support clear by type.  |
| Backup               | You can click this button to backup log files to current PC.   |

### 5.8.7 Vehicle

The vehicle setup interface is shown as in Figure 5-77. Here you can set device auto start and shut down time and plate information.

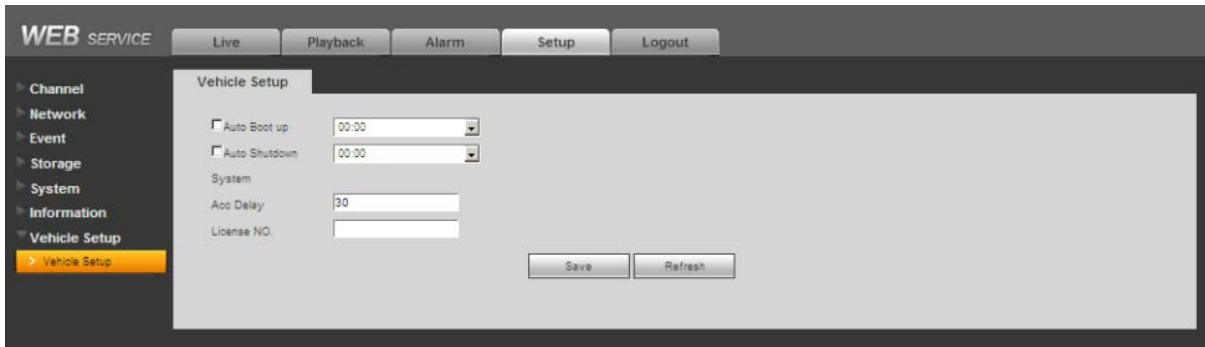

Figure 5-77

## 5.9 Search

Click search button, you can see an interface is shown as in Figure 5-78.

Please set record type, record date, window display mode and channel name.

You can click the date on the right pane to select the date. The green highlighted date is system current date and the blue highlighted date means it has record files.

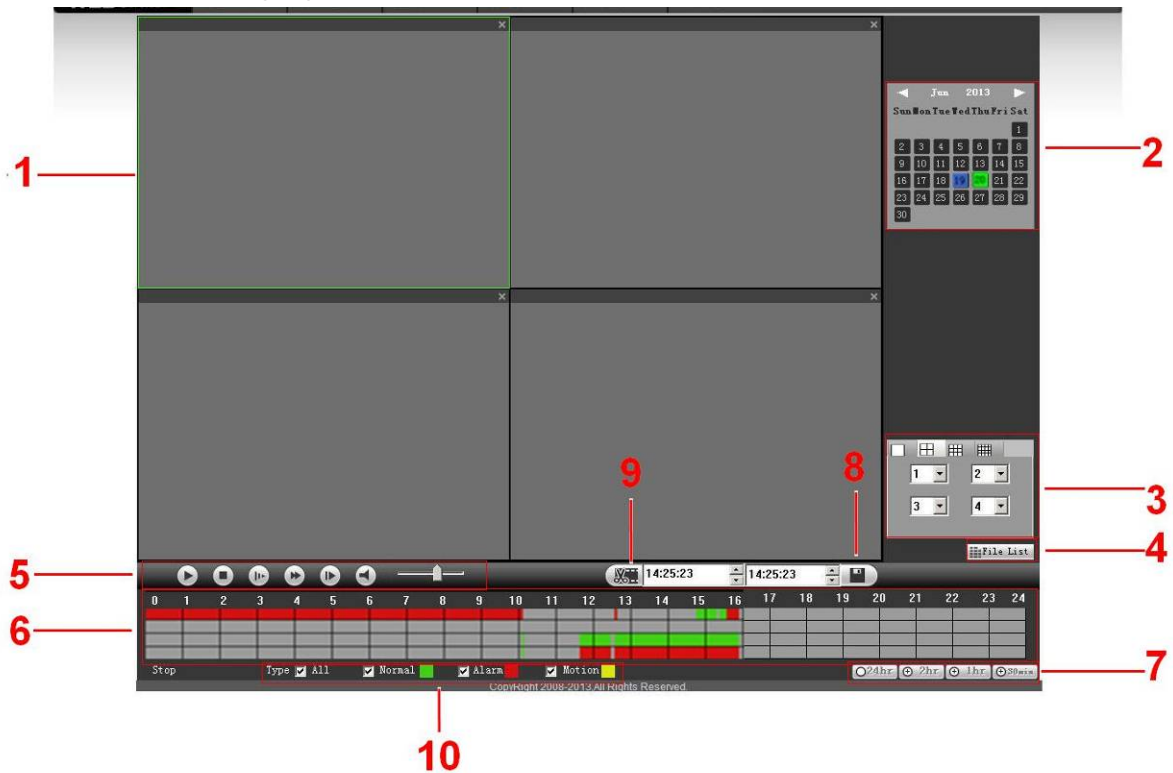













Figure 5-78

Please refer to the following sheet for detailed information.

| SN | Function       | Description   |
|----|----------------|---|
| 1  | Display window | Click  to switch window amount. During the playback process, double click a window to zoom in. |
| 2  | Calendar       | The blue highlighted date means there is picture or file. Otherwise, there is no picture or file.   |

|   |   |  |
|---|---|--|
|   |   | In any play mode, click the date you want to see, you can see the corresponding record file trace in the time bar.   |
| 3 | Playback mode and channel selection pane. | Playback mode: 1/4/9/16-channel.<br>The time bar will change once you modify the playback mode or the channel option.  |
| 4 | File list switch button                   | <ul style="list-style-type: none"> <li>✧ Click it to view record list of current date.</li> <li>✧ Input a time at the top of the interface, you can search record of accurate time. </li> <li>✧ You can view all record files after current search date. Use the ▲/▼ or the mouse to view the file. Select one item, and then double click the mouse or click the ENTER button to playback.</li> <li>✧ File type: R—regular record; A—external alarm record; M—Motion detect record.</li> <li>✧ Download: Save file to current PC.</li> <li>✧ Download more: Set download file(s).</li> </ul> <p>Watermark: It is to check the file has been tampered with or not via the watermark verification.</p>  |
| 5 | Playback control pane.                    | <div style="border: 1px solid black; padding: 5px; margin-bottom: 5px;">  Play/Pause         <p>There are three ways for you to begin playback.</p> <ul style="list-style-type: none"> <li>● The play button</li> <li>● Double click the valid period of the time bar.</li> <li>● Double click the item in the file list.</li> </ul> <p>In slow play mode, click it to switch between play/pause.</p> </div> <div style="border: 1px solid black; padding: 5px; margin-bottom: 5px;">  Stop         </div> <div style="border: 1px solid black; padding: 5px; margin-bottom: 5px;">  <p>In playback mode, click it to play the next or the previous section. You can click continuously when you are watching the files from the same channel.</p> <p>In normal play mode, when you pause current play, you can click ◀  and  ▶ to begin frame by frame playback.</p> <p>In frame by frame playback mode, click ▶/   to restore normal playback. (if you click pause button during normal playback process, you can click ▶  to begin frame by frame playback. )</p> </div> <div style="border: 1px solid black; padding: 5px; margin-bottom: 5px;">  Slow play         <p>In playback mode, click it to realize various slow play modes such as slow play 1, slow play 2, and etc.</p> </div> <div style="border: 1px solid black; padding: 5px;">  Fast forward         <p>In playback mode, click to realize various fast play modes such as fast play 1, fast play 2 and etc.</p> </div> |

|    |               |  |
|----|---------------|--|
|    |               |  <p>Support playback volume. Support mute function.</p>   |
| 6  | Time bar      | <ul style="list-style-type: none"> <li>● It is to display the record type and its period in current search criteria.</li> <li>● In 4-window playback mode, there are corresponding four time bars. In other playback mode, there is only one time bar.</li> <li>● Use the mouse to click one point of the color zone in the time bar, system begins playback.</li> <li>● The time bar is beginning with 0 o'clock when you are setting the configuration. The time bar zooms in the period of the current playback time when you are playing the file.</li> <li>● The green color stands for the regular record file. The red color stands for the external alarm record file. The yellow stands for the motion detect record file.</li> </ul> |
| 7  | Time bar unit | <ul style="list-style-type: none"> <li>● ●The option includes: 24H, 12H, 1H and 30M. The smaller the unit, the larger the zoom rate. You can accurately set the time in the time bar to playback the record.</li> <li>● The time bar is beginning with 0 o'clock when you are setting the configuration. The time bar zooms in the period of the current playback time when you are playing the file.</li> </ul>   |
| 8  | Backup        |  <p>Select the file(s) you want to backup from the file list. System max supports files from four channels. Then click the backup button, now you can see the backup menu. Click the start button to begin the backup operation.<br/>Check the file again you can cancel current selection.<br/>System max supports to display 32 files from one channel.</p>   |
| 9  | Clip          |  <p>It is to edit the file.<br/>Please play the file you want to edit and then click this button when you want to edit. You can see the corresponding slide bar in<br/>the time bar of the corresponding channel such as  and . You can adjust the slide bar or input the accurate time to set the file end time. Click this button again and then save current contents in a new file.</p>   |
| 10 | Record type   | <p>In any play mode, the time bar will change once you modify the search type.<br/>Right now system supports general, alarm, and motion detect.</p>  |

Then please click file list button (Button 4 in Figure 5-78 ), you can see the corresponding files in the list. See Figure 5-79.

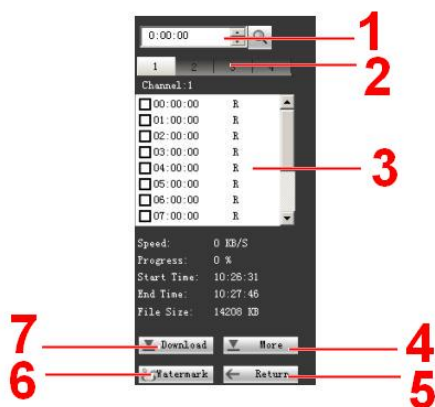

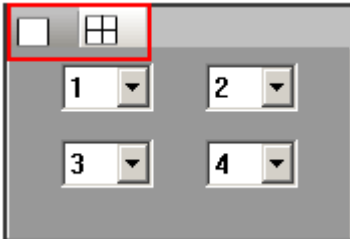



Figure 5-79

| SN | Description  |
|----|--|
| 1  | <p>Please select a date on the calendar pane and then input time here to search records of the specified time.</p>    |
| 2  | <p>Then you can select window mode and channel.</p>   |
| 3  | <p>System displays all records of current date by default. Click Enter button or double a record file you can begin playback.<br/>The record type includes: normal, alarm and motion detect.</p>    |
| 4  | <p>Click More button, you can search record files or picture. You can download by setting record channel, record type and record time.</p> <p>Click start back button on the remote backup interface, it allows you to backup the record or picture to your local USB storage media via the Web remotely. Click the search button; you can view the available storage device. Please select file(s) from the list and then Click Start backup button.</p> <p>You can go to chapter 5.8.1.2.6 to set download path.</p> |
| 5  | Return   |
| 6  | User watermark function to check the record has been tampered with or not.   |
| 7  | <p>Check the file(s) you want to backup ( <input checked="" type="checkbox"/> ) and then click Download to save on your local PC.</p>  |

| SN | Description   |
|----|---|
|    | <b>Important</b><br><b>System max supports select download files from 4-channels.</b> |

## 5.10 Alarm

Click alarm function, you can see an interface is shown as Figure 5-80.  
Here you can set device alarm type and alarm sound setup.

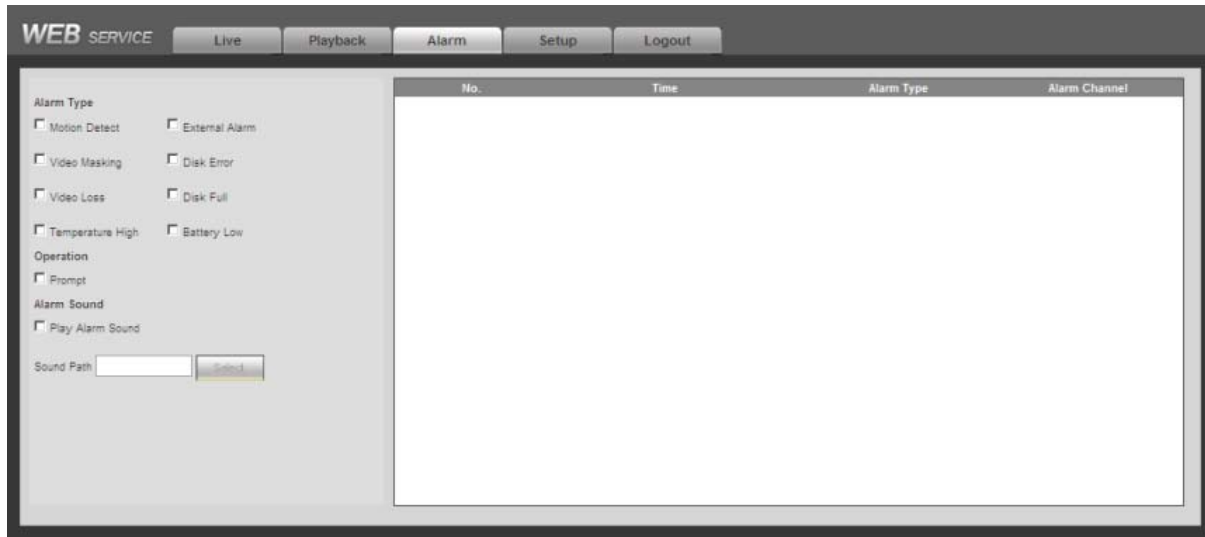

Figure 5-80

Please refer to the following sheet for detailed information.  
Please make sure current device can upload the alarm.

| Type        | Parameter        | Function   |
|-------------|------------------|--|
| Alarm Type  | Video loss       | System alarms when video loss occurs.  |
|             | Motion detection | System alarms when motion detection alarm occurs.  |
|             | Camera masking   | System alarms when camera is viciously masking.  |
|             | Disk full        | System alarms when disk is full.   |
|             | Disk error       | System alarms when disk error occurs.  |
|             | External alarm   | Alarm input device sends out alarm.  |
|             | Temperature high | System alarms when temperature is high.  |
| Operation   | Battery low      | System alarms when battery voltage is low  |
|             | Prompt           | Check the box here, system can automatically pops up an alarm icon on the Alarm button in the main interface when there is an alarm. |
| Alarm Sound | Play alarm sound | System sends out alarm sound when an alarm occurs. You can specify as you wish.  |
|             | Sound path       | Here you can specify alarm sound file.   |

## 5.11 Log out

Click log out button, system goes back to log in interface. See Figure 5-81.  
You need to input user name and password to login again.

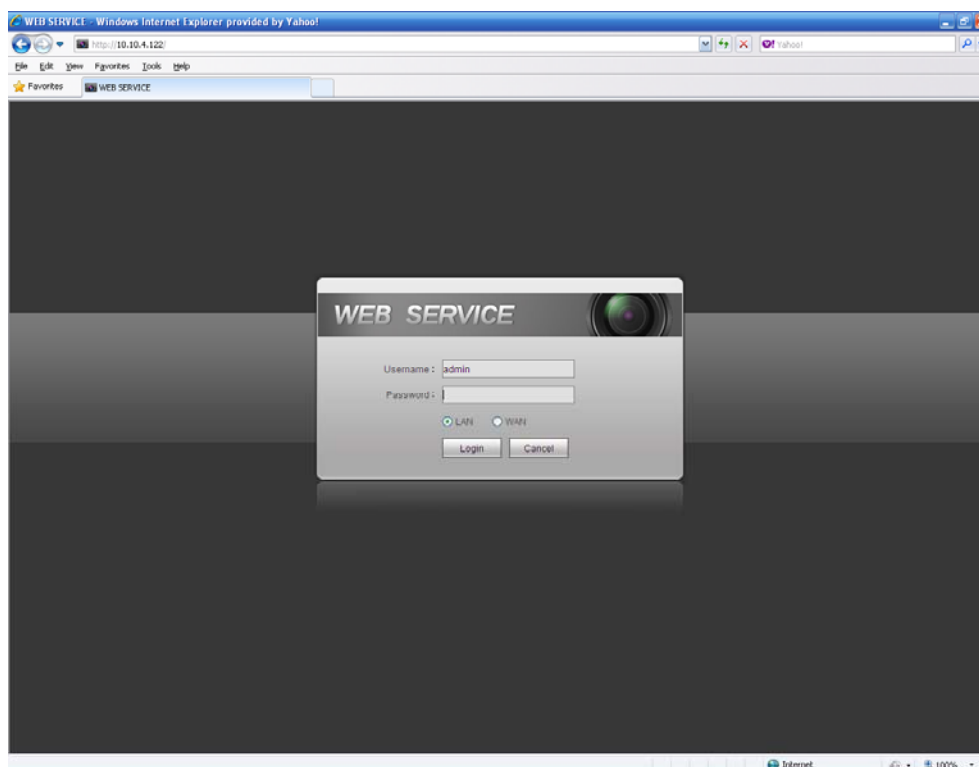

Figure 5-81

## 5.12 Un-install Web Control

You can use web un-install tool “uninstall web.bat” to un-install web control.

**Please note, before you un-installation, please close all web pages, otherwise the un-installation might result in error.**

## 6 Digital Surveillance System

Besides Web, you can use our Digital Surveillance Software (DSS) to login the device.  
For detailed information, please refer to *DSS user's manual*.

## 7 FAQ

### 1. After the vehicle started, the DVR can not boot up properly.

There are following possibilities:

- Input power is not correct. It is too high or too low.
- Power connection is not correct.
- Power switch button is damaged.
- Program upgrade is wrong.
- HDD malfunction or something wrong with HDD ribbon.
- Seagate DB35.1, DB35.2, SV35 or Maxtor 17-g has compatibility problem. Please upgrade to the latest version to solve this problem.
- Front panel error.
- Main board is damaged.

### 2. DVR often automatically shuts down or stops running.

There are following possibilities:

- Input voltage is not stable or it is too low.
- HDD malfunction or something wrong with the ribbon.
- Button power is not enough.
- Front video signal is not stable.
- Working environment is too harsh, too much dust.
- Hardware malfunction.

### 3. System can not detect hard disk.

There are following possibilities:

- HDD is broken.
- HDD ribbon is damaged.
- HDD cable connection is loose.
- Main board SATA port is broken.

### 4. There is no video output whether it is one-channel, multiple-channel or all-channel output.

There are following possibilities:

- Program is not compatible. Please upgrade to the latest version.
- Brightness is 0. Please restore factory default setup.
- There is no video input signal or it is too weak.
- Check privacy mask setup or your screen saver.
- DVR hardware malfunctions.

### 5. Real-time video color is distorted.

There are following possibilities:

- When using BNC output, NTSC and PAL setup is not correct. The real-time video becomes black and white.
- DVR and monitor resistance is not compatible.

- Video transmission is too long or degrading is too huge.
- DVR color or brightness setup is not correct.

#### **6. Can not search local records.**

There are following possibilities:

- HDD ribbon is damaged.
- HDD is broken.
- Upgraded program is not compatible.
- The recorded file has been overwritten.
- Record function has been disabled.

#### **7. Video is distorted when searching local records.**

There are following possibilities:

- Video quality setup is too low.
- Program read error, bit data is too small. There is mosaic in the full screen. Please restart the DVR to solve this problem.
- HDD data ribbon error.
- HDD malfunction.
- DVR hardware malfunctions.

#### **8. There is no audio when monitor.**

There are following possibilities:

- It is not a power picker.
- It is not a power acoustics.
- Audio cable is damaged.
- DVR hardware malfunctions.

#### **9. There is audio when monitor but there is no audio when system playback.**

There are following possibilities:

- Setup is not correct. Please enable audio function
- Corresponding channel has no video input. Playback is not continuous when the screen is blue.

#### **10. Time display is not correct.**

There are following possibilities:

- Setup is not correct
- Battery contact is not correct or voltage is too low.
- Crystal is broken.

#### **11. DVR can not control PTZ.**

There are following possibilities:

- Front panel PTZ error
- PTZ decoder setup, connection or installation is not correct.
- Cable connection is not correct.
- PTZ setup is not correct.

- PTZ decoder and DVR protocol is not compatible.
- PTZ decoder and DVR address is not compatible.
- When there are several decoders, please add 120 Ohm between the PTZ decoder A/B cables furthest end to delete the reverberation or impedance matching. Otherwise the PTZ control is not stable.
- The distance is too far.

## **12. Motion detection function does not work.**

There are following possibilities:

- Period setup is not correct.
- Motion detection zone setup is not correct.
- Sensitivity is too low.
- For some versions, there is hardware limit.

## **13. Can not log in client-end or web.**

There are following possibilities:

- For Windows 98 or Windows ME user, please update your system to Windows 2000 sp4. Or you can install client-end software of lower version. Please note right now, our DVR is not compatible with Windows VISTA control.
- ActiveX control has been disabled.
- No dx8.1 or higher. Please upgrade display card driver.
- Network connection error.
- Network setup error.
- Password or user name is invalid.
- Client-end is not compatible with DVR program.

## **14. There is only mosaic no video when preview or playback video file remotely.**

There are following possibilities:

- Network fluency is not good.
- Client-end resources are limit.
- There is multiple-cast group setup in DVR. This mode can result in mosaic. Usually we do not recommend this mode.
- There is privacy mask or channel protection setup.
- Current user has no right to monitor.
- DVR local video output quality is not good.

## **15. Network connection is not stable.**

There are following possibilities:

- Network is not stable.
- IP address conflict.
- MAC address conflict.
- PC or DVR network card is not good.

## **16. USB backup error.**

There are following possibilities:

- Burner and DVR are in the same data cable.
- System uses too much CPU resources. Please stop record first and then begin backup.
- Data amount exceeds backup device capacity. It may result in burner error.
- Backup device is not compatible.
- Backup device is damaged.

#### **17. Alarm signal can not be disarmed.**

There are following possibilities:

- Alarm setup is not correct.
- Alarm output has been open manually.
- Input device error or connection is not correct.
- Some program versions may have this problem. Please upgrade your system.

#### **18. Alarm function is null.**

There are following possibilities:

- Alarm setup is not correct.
- Alarm cable connection is not correct.
- Alarm input signal is not correct.
- There are two loops connect to one alarm device.

#### **19. Remote control does not work.**

There are following possibilities:

- Remote control address is not correct.
- Distance is too far or control angle is too small.
- Remote control battery power is low.
- Remote control is damaged or DVR front panel is damaged.

#### **20. Record storage period is not enough.**

There are following possibilities:

- Camera quality is too low. Lens is dirty. Camera is installed against the light. Camera aperture setup is not correct.
- HDD capacity is not enough.
- HDD is damaged.

#### **21. Can not playback the downloaded file.**

There are following possibilities:

- There is no media player.
- No DXB8.1 or higher graphic acceleration software.
- There is no DivX503Bundle.exe control when you play the file transformed to AVI via media player.
- No DivX503Bundle.exe or ffdshow-2004 1012 .exe in Windows XP OS.

#### **22. My cell phone 3G dial failed.**

There are following possibilities:

- You have not installed the dial module or your installation is not right.

- Please make sure you have inserted the card.
- You have not installed the antenna or the connection is not sound.
- The centre platform configuration is not right or the registration is not effective.
- The cell phone remaining sum is not sufficient.
- Signal is too weak.
- SIM card does not support corresponding service.

## **Daily Maintenance**

- Do not allow other objects falling into the DVR (such as water), it may result in device malfunction.
- Always follow the transportation instructions. Do not transport the DVR upside down.
- Please pay attention to the cable connection. The improper connection steps may result in device malfunction or damage.
- Please make sure all the external cables have soundly earthed.
- Before you connect the power cable, please make sure other cables have properly connected.
- Use the cable strap in case there is short circuit, electric shock.
- Please keep the power cable neat in case it obstacles the driver or the passenger.
- Please remove the negative end (-) of the connection terminal before you configure the cable.
- Please unlock the key before you draw out the HDD box. Otherwise it may result in device damage.
- When washing the vehicle, please keep the DVR away from the water. Otherwise it may result in short circuit, fire or device malfunctions.
- Please make sure the DVR is away from the direct sunlight or other heating sources. Please keep the sound ventilation.
- Please use the brush to clean the board, socket connector and the chassis regularly.
- The DVR shall be soundly earthed in case there is audio/video disturbance. Keep the DVR away from the static voltage or induced voltage.
- Please unplug the power cable when you remove the audio/video signal cable, RS232 or RS485 cable.
- Please check the DVR is secured firmly and horizontally. Please make sure the anti-vibration component can work properly.
- Please check and maintain the DVR regularly.

## 8 Appendix A HDD Capacity Calculation

Calculate total capacity needed by each device according to video recording (video recording type and video file storage time).

Step 1: According to Formula (1) to calculate storage capacity  $q_i$  that is the capacity of each channel needed for each hour, unit Mbyte.

$$q_i = d_i \div 8 \times 3600 \div 1024 \quad (1)$$

In the formula:  $d_i$  means the bit rate, unit Kbit/s

Step 2: After video time requirement is confirmed, according to Formula (2) to calculate the storage capacity  $m_i$ , which is storage of each channel needed unit Mbyte.

$$m_i = q_i \times h_i \times D_i \quad (2)$$

In the formula:

$h_i$  means the recording time for each day (hour)

$D_i$  means number of days for which the video shall be kept

Step 3: According to Formula (3) to calculate total capacity (accumulation)  $q_T$  that is needed for all channels in the device during **scheduled video recording**.

$$q_T = \sum_{i=1}^c m_i \quad (3)$$

In the formula:  $c$  means total number of channels in one device

Step 4: According to Formula (4) to calculate total capacity (accumulation)  $q_T$  that is needed for all channels in device during **alarm video recording (including motion detection)**.

$$q_T = \sum_{i=1}^c m_i \times a\% \quad (4)$$

In the formula:  $a\%$  means alarm occurrence rate

## 9 Appendix B Compatible SATA HDD

| Manufacturer | Series                           | Model           | Capacity | Port Mode |
|--------------|----------------------------------|-----------------|----------|-----------|
| Hitachi      | CINEMASTAR series for DVR use    | HCC545025B9A300 | 250GB    | SATA      |
| Hitachi      | CINEMASTAR series for DVR use    | HCC545016B9A300 | 160GB    | SATA      |
|              | Recommend HCC series for DVR use |                 |          |           |
| Hitachi      | 5K500.B laptop series            | HTS545025B9A300 | 250GB    | SATA      |
| Hitachi      | 5K500.B laptop series            | HTS545016B9A300 | 160GB    | SATA      |
| Hitachi      | 5K500.B laptop series            | HTS545012B9A300 | 120GB    | SATA      |

## Appendix C Glossary

- **DHCP:** Dynamic Host Configuration Protocol (DHCP) is a network protocol. It is one of the TCP/IP protocol cluster. It is principally used to assign temporary IP addresses to computers on a network.
- **NTP:** Network Time Protocol (NTP) is a protocol built on top of TCP/IP that assures accurate local timekeeping with reference to radio, atomic or other clocks located on the Internet. This protocol is capable of synchronizing distributed clocks within milliseconds over long time periods. It can avoid malicious attack via the encryption verification.
- **GPS:** Global Positioning System (GPS) is a satellite system, protected by the US military, safely orbiting thousands of kilometers above the earth.
- **WIFI:** Wi-Fi is the name of a popular wireless networking technology that uses radio waves to provide wireless high-speed Internet and network connections. The standard is for wireless local area networks (WLANs). It is like a common language that all the devices use to communicate to each other. It is actually IEEE802.11, a family of standard The IEEE (Institute of Electrical and Electronics Engineers Inc.)
- **3G:** 3G is the wireless network standard. It is called 3G because it is the third generation of cellular telecom standards. 3G is a faster network for phone and data transmission and speed is over several hundreds kbps. Now there are four standards: CDMA2000, WCDMA, TD-SCDMA and WiMAX.
- **Dual-stream:** The dual-stream technology adopts high-rate bit stream for local HD storage such as QCIF/CIF/2CIF/DCIF/4CIF encode and one low-rate bit stream for network transmission such as QCIF/CIF encode. It can balance the local storage and remote network transmission. The dual-stream can meet the difference band width requirements of the local transmission and the remote transmission. In this way, the local transmission using high-bit stream can achieve HD storage and the network transmission adopting low bit stream suitable for the fluency requirements of the 3G network such as WCDMA, EVDO, TD-SCDMA..
- **On-off value:** It is the non-consecutive signal sampling and output. It includes remote sampling and remote output. It has two statuses: 1/0.

## Appendix D Toxic or Hazardous Materials or Elements

| Component Name            | Toxic or Hazardous Materials or Elements |    |    |       |     |      |
|---------------------------|--|----|----|-------|-----|------|
|                           | Pb                                       | Hg | Cd | Cr VI | PBB | PBDE |
| Sheet Metal(Case)         | ○  | ○  | ○  | ○     | ○   | ○    |
| Plastic Parts (Panel)     | ○  | ○  | ○  | ○     | ○   | ○    |
| Circuit Board             | ○  | ○  | ○  | ○     | ○   | ○    |
| Fastener                  | ○  | ○  | ○  | ○     | ○   | ○    |
| Wire and Cable/Ac Adapter | ○  | ○  | ○  | ○     | ○   | ○    |
| Packing Material          | ○  | ○  | ○  | ○     | ○   | ○    |
| Accessories               | ○  | ○  | ○  | ○     | ○   | ○    |

**Note**

O: Indicates that the concentration of the hazardous substance in all homogeneous materials in the parts is below the relevant threshold of the SJ/T11363-2006 standard.

X: Indicates that the concentration of the hazardous substance of at least one of all homogeneous materials in the parts is above the relevant threshold of the SJ/T11363-2006 standard. During the environmental-friendly use period (EFUP) period, the toxic or hazardous substance or elements contained in products will not leak or mutate so that the use of these (substances or elements) will not result in any severe environmental pollution, any bodily injury or damage to any assets. The consumer is not authorized to process such kind of substances or elements, please return to the corresponding local authorities to process according to your local government statutes.

**Note**

- **This manual is for reference only. Slight difference may be found in the user interface.**
- **All the designs and software here are subject to change without prior written notice.**
- **All trademarks and registered trademarks are the properties of their respective owners.**
- **If there is any uncertainty or controversy, please refer to the final explanation of us.**
- **Please visit our website or contact your local service engineer for more information.**