

Megapixel Indoor Network Camera Quick Start Guide

Version 3.1.0

Welcome

Thank you for purchasing our network camera!

This quick start guide is designed to be a reference tool for your system.

Please keep this start guide well for future reference.

1 . Electrical safety

All installation and operation here should conform to your local electrical safety codes.

The power shall conform to the requirement in the SELV (Safety Extra Low Voltage) and the Limited power source is rated 12V DC or 24V AC in the IEC60950-1. (Refer to general introduction) **Please note: Do not connect two power supplying sources to the device at the same time; it may result in device damage!**

We assume no liability or responsibility for all the fires or electrical shock caused by improper handling or installation.

We are not liable for any problems caused by unauthorized modification or attempted repair.

2 . Transportation security

Heavy stress, violent vibration or water splash are not allowed during transportation, storage and installation.

3 . Installation

Do not apply power to the camera before completing installation.

Please install the proper power cut-off device during the installation connection.

Always follow the instruction guide the manufacturer recommended.

4 . Qualified engineers needed

All the examination and repair work should be done by the qualified service engineers.

We are not liable for any problems caused by unauthorized modifications or attempted repair.

5 . Environment

This series network camera should be installed in a cool, dry place away from direct sunlight, inflammable, explosive substances and etc.

Please keep it away from the electromagnetic radiation object and environment.

Please make sure the CCD (CMOS) component is out of the radiation of the laser beam device.

Otherwise it may result in CCD (CMOS) optical component damage.

Please keep the sound ventilation.

Do not allow the water and other liquid falling into the camera.

Thunder-proof device is recommended to be adopted to better prevent thunder.

The grounding studs of the product are recommended to be grounded to further enhance the reliability of the camera.

6. Daily Maintenance

Please shut down the device and then unplug the power cable before you begin daily maintenance work.

Do not touch the CCD (CMOS) optic component. You can use the blower to clean the dust on the lens surface.

Always use the dry soft cloth to clean the device. If there is too much dust, please use the water to dilute the mild detergent first and then use it to clean the device. Finally use the dry cloth to clean the device.

Please put the dustproof cap to protect the CCD (CMOS) component when you do not use the camera. Dome enclosure is the optical component, do not touch the enclosure when you are installing the device or clean the enclosure when you are doing maintenance work. Please use professional optical clean method to clean the enclosure. Improper enclosure clean method (such as use cloth) may result in poor IR effect of camera with IR function.

7. Accessories

Be sure to use all the accessories recommended by manufacturer.

Before installation, please open the package and check all the components are included.

Contact your local retailer ASAP if something is broken in your package.

Accessory Name	Amount
Network Camera Unit	1
C/CS Adapter ring	1
Quick Start Guide	1
CD	1

Table of Contents

1	Framework.....	1
1.1	Rear Panel.....	1
1.2	Side Panel	8
1.3	Front Panel.....	8
1.4	Bidirectional talk.....	9
1.4.1	Device-end to PC-end	9
1.4.2	PC-end to the Device-end.....	9
1.5	Alarm Setup.....	9
1.5.1	Alarm Input and Output Connection	10
1.5.2	IR Light Connection.....	11
2	Installation.....	12
2.1	Lens Installation.....	12
2.1.1	Auto Aperture Lens	12
2.1.2	Manual Lens.....	12
2.1.3	Remove Lens.....	13
2.2	SD Card	13
2.2.1	Installation.....	13
2.2.2	Remove.....	14
2.3	3G Card.....	15
2.3.1	Installation.....	15
2.3.2	Remove.....	15
2.4	3G/WIFI Antenna.....	16
2.4.1	Installation.....	16
2.4.2	Remove.....	17
2.5	I/O Port.....	18
2.5.1	Install and Remove Cable.....	18
3	Quick Configuration Tool.....	19
3.1	Overview	19

3.2	Operation	19
4	Web Operation.....	21
4.1	Network Connection.....	21
4.2	Login and Main Interface.....	21
	Appendix Toxic or Hazardous Materials or Elements	24

1 Framework

1.1 Rear Panel

This series network camera rear panel is shown as below. See Figure 1-1.

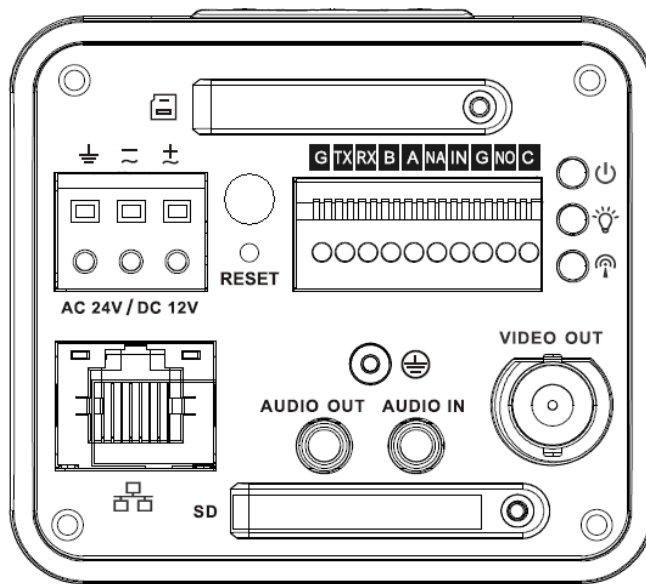

The rear panel with the network port

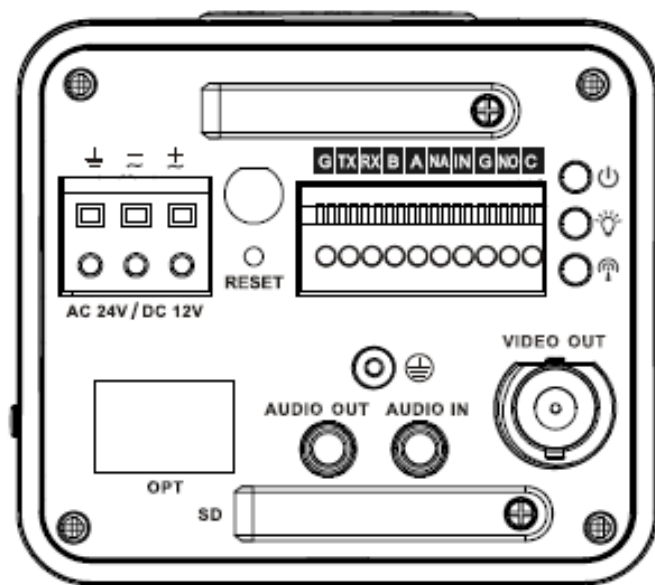





The rear panel with the 100M fiber port

Figure 1-1 Rear panel





Please refer to the following sheet for detail information.

Interface Name		Connector	Function
VIDEO OUT	Video output port	BNC	Output analog video signal. Can connect to

			TV monitor to view video.
AC 24V/ DC 12V	Power port		<ul style="list-style-type: none"> ● Power port. ● Input 12V DC or AC 24V
STATUS Indication Light	Red light 		<ul style="list-style-type: none"> ● System boot up- red light is on ● System upgrades- red light flashes ● System resets- red light flashes.
	Green light 		<ul style="list-style-type: none"> ● Normal working status- green light is on. ● Display record status: Record- green light flashes.
	Yellow light 		<ul style="list-style-type: none"> ● Detect the wireless device- yellow light is on.
	3G		Connect to 3G card. Please note it is for 3G series product only.
WIFI	Antenna port		Connect to 3G/WIFI antenna to receive the wireless signal. Please note this function is for some series products only.
IN	Alarm input port	I/O port	Alarm input port 1. To receive the signal from

			the external alarm device.
NO	Alarm output port		Alarm output port. To output alarm signal to the alarm device. <ul style="list-style-type: none"> ● NO: Normal open alarm output end. ● C: Alarm output public end.
C			
G	GND		Alarm input ground end.
A	RS485 port		RS485_A port, control external PTZ
B			RS485_B port, control external PTZ
RX	RS232 port		RS232_RX, RS232 receive end.
TX			RS232_TX, RS232 COM send out end.
G	GND		RS232 ground end
NA	IR light port		External IR light signal control port.
RESET	RESET button		Restore factory default setup. When system is running normally, press the RESET button for at least 5 seconds, system can restore factory default setup.
AUDIO OUT	Audio output port	Audio output 3.5mm JACK port.	Output audio signal to the passive device such as earphone.
AUDIO IN	Audio input port	Audio input 3.5mm	Input audio signal

		JACK port.	from devices such as pick-up.
LAN 	Network port	Ethernet port	<ul style="list-style-type: none"> ● Connect to standard Ethernet cable. ● Support PoE function.
OPT	100M fiber port	155M single fiber dual-direction SFP fiber module	Transmit 100M Ethernet data.
SD	SD card port		<p>Connect to SD card.</p> <p>Note</p> <ul style="list-style-type: none"> ● When you install the SD card, please make sure current card is not in write mode and then you can install it to the camera. ● When you remove the SD card, please make sure current card is not in write mode. Otherwise it may result in data loss or card damage. ● Before hot swap, please stop record operation.

	GND		Please make sure the device is securely earthed to prevent the thunderstorm strike.
Interface Name		Connector	Function
VIDEO OUT	Video output port	BNC	Output analog video signal. Can connect to TV monitor to view video.
AC 24V/ DC 12V	Power port		<ul style="list-style-type: none"> ● Power port. ● Input 12V DC or AC 24V
STATUS Indication Light	Red light 		<ul style="list-style-type: none"> ● System boot up- red light is on ● System upgrades-red light flashes ● System resets- red light flashes.
	Green light 		<ul style="list-style-type: none"> ● Normal working status-green light is on. ● Display record status:Record-green light flashes.
	Yellow light 		<ul style="list-style-type: none"> ● Detect the wireless device- yellow light is on.
	3G		Connect to 3G card. Please note it is for 3G series product only.

WIFI	Antenna port		Connect to 3G/WIFI antenna to receive the wireless signal. Please note this function is for some series products only.
IN	Alarm input port	I/O port	Alarm input port 1. To receive the signal from the external alarm device.
NO	Alarm output port		Alarm output port. To output alarm signal to the alarm device. <ul style="list-style-type: none"> ● NO: Normal open alarm output end. ● C: Alarm output public end.
C			
G	GND		Alarm input ground end.
A	RS485 port		RS485_A port, control external PTZ
B			RS485_B port, control external PTZ
RX	RS232 port		RS232_RX, RS232 receive end.
TX			RS232_TX, RS232 COM send out end.
G	GND	RS232 ground end	
NA	IR light port		External IR light signal control port.
RESET	RESET button		Restore factory default setup. When system is running normally, press the RESET

			button for at least 5 seconds, system can restore factory default setup.
AUDIO OUT	Audio output port	Audio output 3.5mm JACK port.	Output audio signal to the passive device such as earphone.
AUDIO IN	Audio input port	Audio input 3.5mm JACK port.	Input audio signal from devices such as pick-up.
LAN 	Network port	Ethernet port	<ul style="list-style-type: none"> ● Connect to standard Ethernet cable. ● Support PoE function.
OPT	100M fiber port	155M single fiber dual-direction SFP fiber module	Transmit 100M Ethernet data.
SD	SD card port		<p>Connect to SD card.</p> <p>Note</p> <ul style="list-style-type: none"> ● When you install the SD card, please make sure current card is not in write mode and then you can install it to the camera. ● When you remove the SD card, please make sure current card is not in write mode. Otherwise it may result in

			<p>data loss or card damage.</p> <ul style="list-style-type: none"> ● Before hot swap, please stop record operation.
	GND		<p>Please make sure the device is securely earthed to prevent the thunderstorm strike.</p>

1.2 Side Panel

Please refer to the following interface for side panel dimension information. The unit is mm. See Figure 1-2.

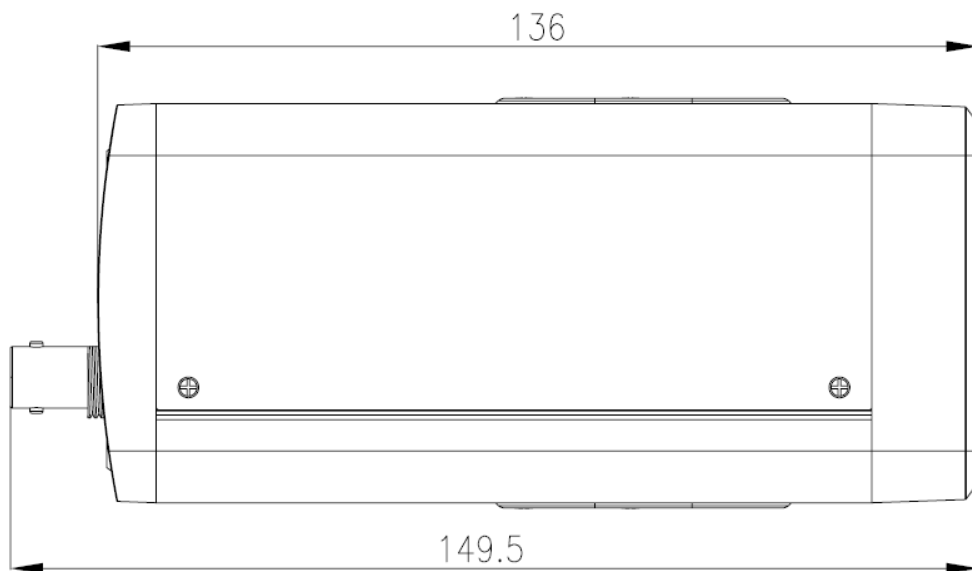

Figure 1-2 Side panel

1.3 Front Panel

Please refer to the following interface for the front panel information. The unit is mm. See Figure 1-3.

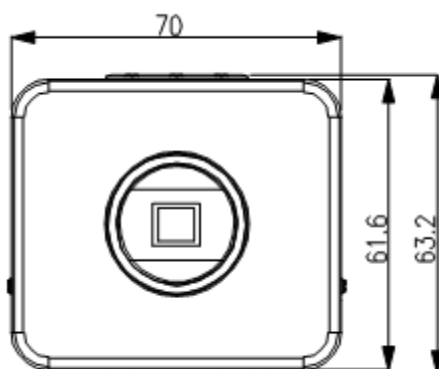

Figure 1-3 Front panel

1.4 Bidirectional talk

1.4.1 Device-end to PC-end

Device Connection

Please connect the speaker or the MIC to the audio input port in the device rear panel. Then connect the earphone to the audio output port in the PC.

Login the Web and then click the Audio button to enable the bidirectional talk function.

You can see the button becomes orange after you enabled the audio talk function.

Click Audio button again to stop the bidirectional talk function.

Listening Operation

At the device end, speak via the speaker or the pickup, and then you can get the audio from the earphone or sound box at the pc-end.

1.4.2 PC-end to the Device-end

Device Connection

Connect the speaker or the MIC to the audio input port in the PC and then connect the earphone to the audio output port in the device rear panel.

Login the Web and then click the Audio button to enable the bidirectional talk function.

You can see the button becomes orange after you enabled the audio talk function.

Click Audio button again to stop the bidirectional talk function.

Please note the listening operation is null during the bidirectional talk process.

Listening Operation

At the PC-end, speak via the speaker or the pickup, and then you can get the audio from the earphone or sound box at the device-end.

1.5 Alarm Setup

The alarm interface is shown as in Figure 1-4.

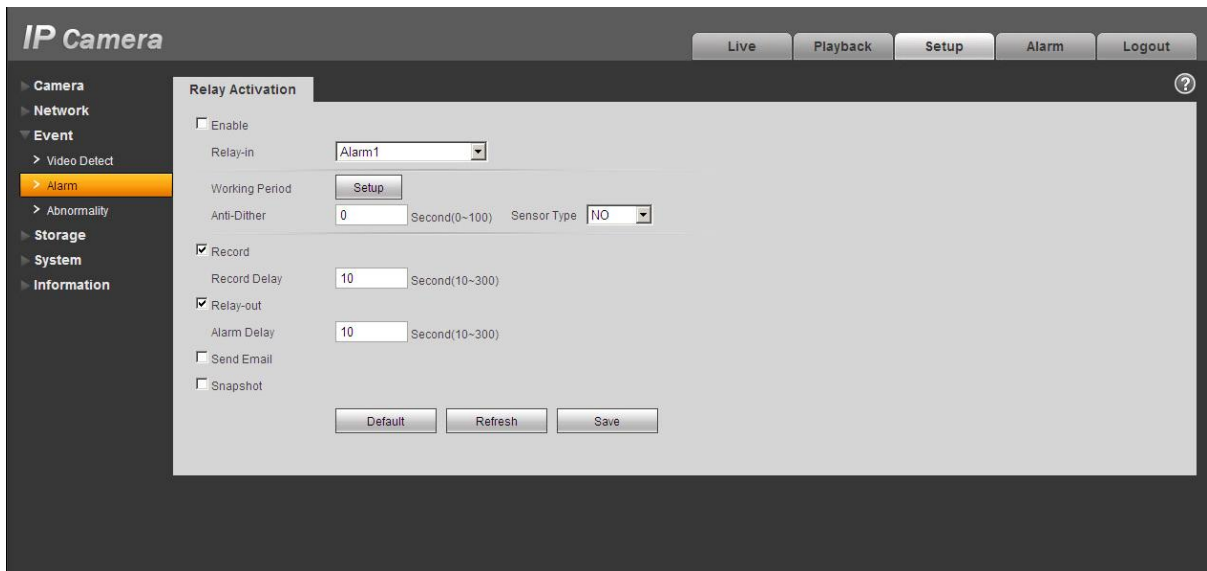

Figure 1-4 Alarm

The alarm setup interface is shown as below.

- Step 1. Connect the alarm input device to the IN alarm input port on the rear panel.
- Step 2. Connect the alarm output device to the NO alarm output port and C alarm output public port on the rear panel. The alarm output port supports NO (normal open) alarm device only.
- Step 3. Open the Web, go to the Figure 1-4. Here you can set the alarm input setup and alarm output setup. Here the alarm input is the alarm input on the rear panel (as IN port). Then you can select the corresponding type (NO/NC) according to the high/low level type when an alarm occurs.
- Step 4. Set the WEB alarm output. The alarm output 01 is the alarm output port of the device rear panel (as the NO port).

1.5.1 Alarm Input and Output Connection

Please refer to the following figure for alarm input information. See 错误! 未找到引用源。 .
 Alarm input: When the input signal is idle or grounded, the device can collect the different statuses of the alarm input port. When the input signal is connected to the 5V or is idle, the device collects the logic “1”. When the input signal is grounded, the device collects the logic “0”.

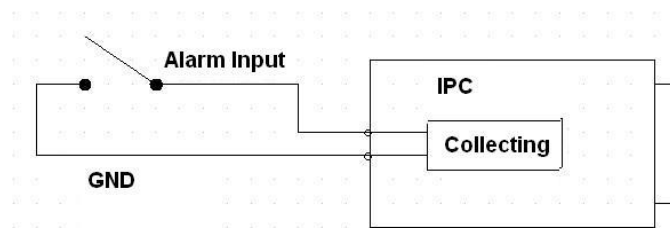

Figure 1-5 Alarm input

Please refer to the following figure for alarm output information. See 错误! 未找到引用源。 .
 Port NO and Port C composes an on-off button to provide the alarm output.
 If the type is NO, this button is normal open. The button becomes on when there is an alarm output.

If the type is NC, this button is normal off. The button becomes off when there is an alarm output.

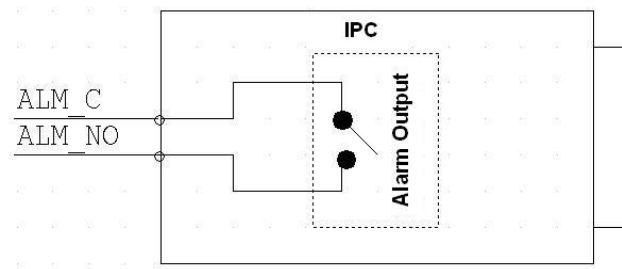

Figure 1-6 Alarm output

1.5.2 IR Light Connection

Please refer to the following figure for external IR light information. See 错误! 未找到引用源。 . IR synchronization input signal. When the external IR light is on, the signal cable from the board outputs the 3.3V/1mA. It outputs the 0V when the IR light is off.

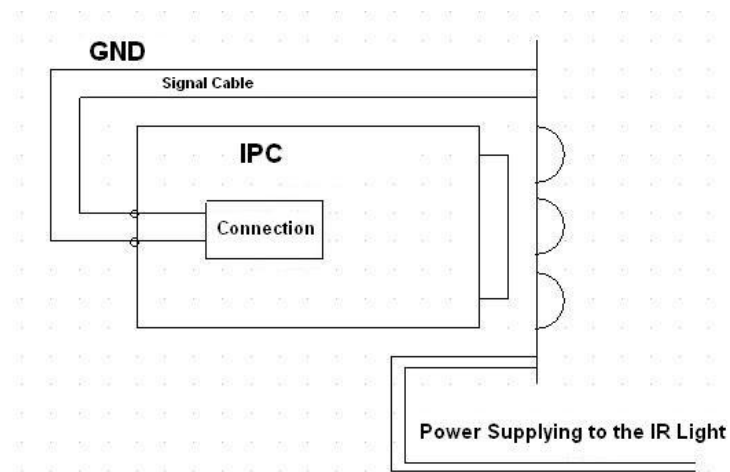

Figure 1-7 IR light connection

2 Installation

2.1 Lens Installation

2.1.1 Auto Aperture Lens

Please follow the steps listed below for auto aperture lens installation. The interface is shown as in Figure 2-1.

- Remove the CCD protection cap of the device, and then line up the lens to the proper installation position. Turn clockwise until the lens is fixed firmly.
- Insert the lens cable socket to the auto lens connector in the side panel.

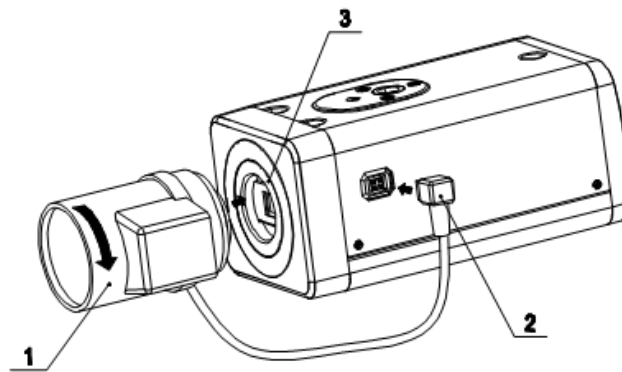

Figure 2-1 Auto aperture lens

2.1.2 Manual Lens

Install C type lens

- Remove the CCD protection cap from the device.
- Install the C/CS adapter to the camera. Turn clockwise to secure against the focusing ring firmly.
- Line up the C lens to the installation position of the C/CS adapter. Turn clockwise to fix the lens.
- Use slotted screwdriver to fasten the screw near the focusing ring and then turn counter clockwise to move the focusing ring out for several millimeters. Now you can focus manually and check the video is clear or not. If you can not see the clear video, you can adjust via the flange-back.
- After you completed the focus setup, use the slotted screwdriver to fix the screw firmly. Fasten the focusing ring. Now the installation completed.

Install CS type lens

- Remove the CCD protection cap from the device.
- Line up the CS lens to the lens installation position of camera focusing ring. Turn clockwise to fix the lens.
- Use slotted screwdriver to fasten the screw near the focusing ring and then turn counter clockwise to move the focusing ring out for several millimeters. Now you can focus manually and check the video is clear or not. If you can not see the clear video, you can adjust via the flange-back.

- After you completed the focus setup, use the slotted screwdriver to fix the screw firmly. Fasten the focusing ring. Now the installation completed.

See Figure 2-2.

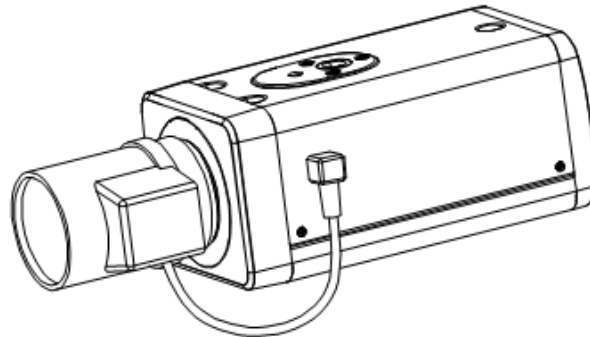

Figure 2-2 Manual lens

2.1.3 Remove Lens

Please follow the steps listed below to remove lens. The interface is shown as in Figure 2-3.

- Turn the lens counter clockwise and then remove it from the camera.
- Unplug the auto lens cable socket from the auto lens connector. If you are using the manual aperture lens, please skip to the following step.
- If there is no lens, please put the CCD protection cap back to protect the CCD.

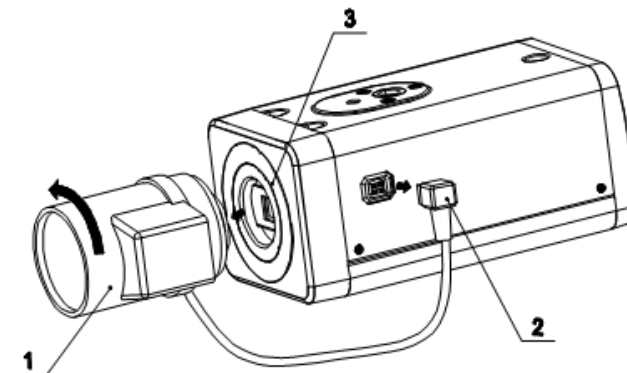

Figure 2-3 Remove lens

2.2 SD Card

2.2.1 Installation

Please follow the steps listed below to install SD card. The interface is shown as in Figure 2-4 and Figure 2-5.

- Use the screwdriver to loosen the SD card protection screw in the rear panel, and then remove the SD card protection cap from the camera.

- Install the SD card to the camera according to the proper installation position.
- Put the SD card protection cap back.
- Use the screwdriver to fix the SD card protection cap screw firmly to secure the SD card protection cap in the camera.

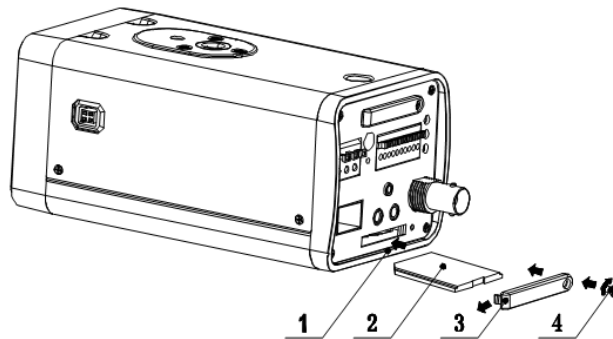

Figure 2-4 SD card installation 1

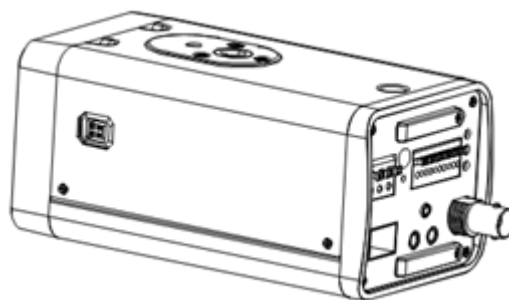

Figure 2-5 SD card installation 2

2.2.2 Remove

Please follow the steps listed below to remove SD card. The interface is shown as Figure 2-6.

- Use the screwdriver to loosen the screw of SD card protection cap in the rear panel. Remove the cap from the camera.
- Follow the SD card direction to remove the SD card.
- Insert the SD card protection cap.
- Use the screwdriver to fix the screw to secure the protection cap.

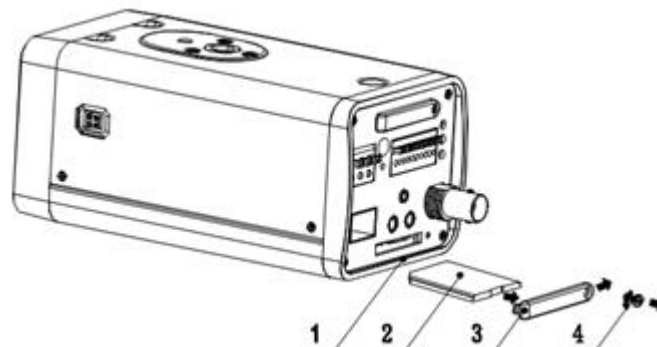

Figure 2-6 Remove SD card

2.3 3G Card

2.3.1 Installation

The 3G card installation is the same with the SD card.

Please follow the steps listed below to install 3G card. The interfaces are shown as Figure 2-7 and Figure 2-8.

- Use the screwdriver to loosen the 3G card protection cap screw in the side panel, and then remove the 3G card protection cap from the camera.
- Install the 3G card to the camera according to the proper installation position.
- Put the 3G card protection cap back.
- Use the screwdriver to fix the 3G card protection cap screw firmly to secure the 3G card protection cap.

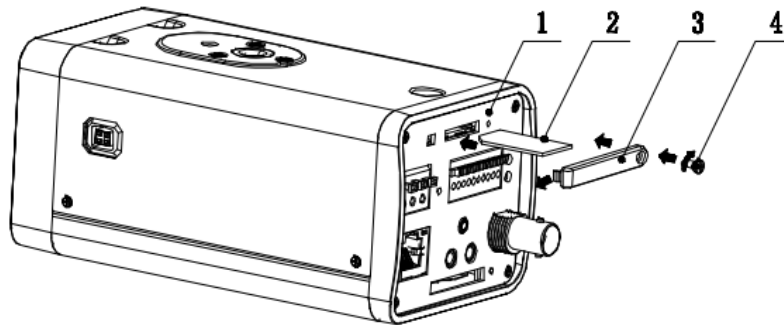

Figure 2-7 3G card installation 1

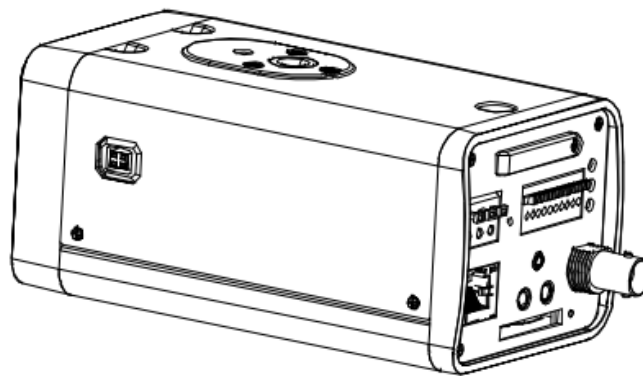

Figure 2-8 3G card installation 2

2.3.2 Remove

Please follow the steps listed below to remove 3G card. The interface is shown as Figure 2-9.

- Use the screwdriver to loosen the screw of 3G card protection cap in the rear panel. Remove the cap from the camera.
- Follow the 3G card direction to remove the 3G card.
- Insert the 3G card protection cap.
- Use the screwdriver to fix the screw to secure the protection cap.

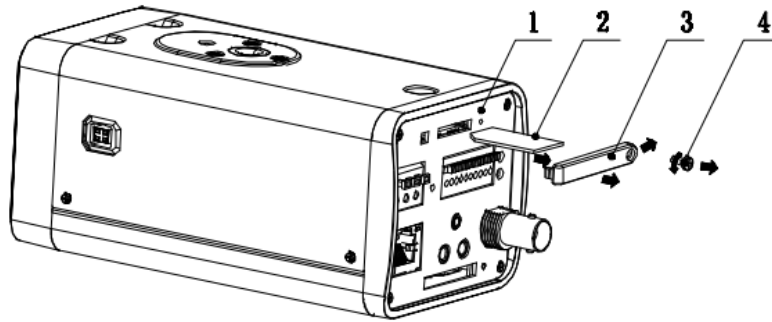

Figure 2-9 Remove 3G card

2.4 3G/WIFI Antenna

2.4.1 Installation

Line up the thread of the screw of the 3G/WIFI antenna to the thread of the rear panel. See Figure 2-10.

Please turn according to the direction in the following figure until antenna is secure firmly. See Figure 2-11.

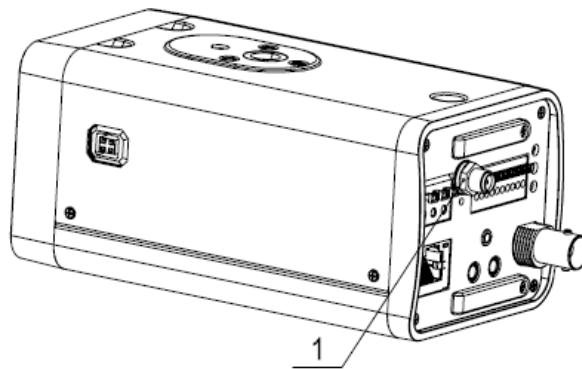

Figure 2-10 3G/Wifi antenna installation 1

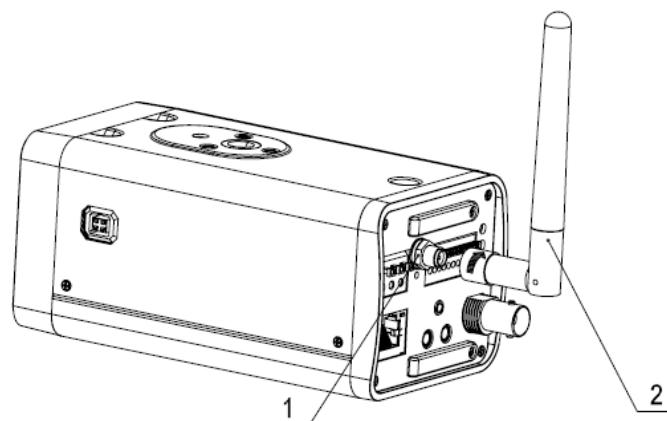

Figure 2-11 3G/Wifi antenna installation 2

After you fix the 3G/WIFI antenna to the WIFI port of the rear panel, you can adjust the antenna direction. See Figure 2-12.

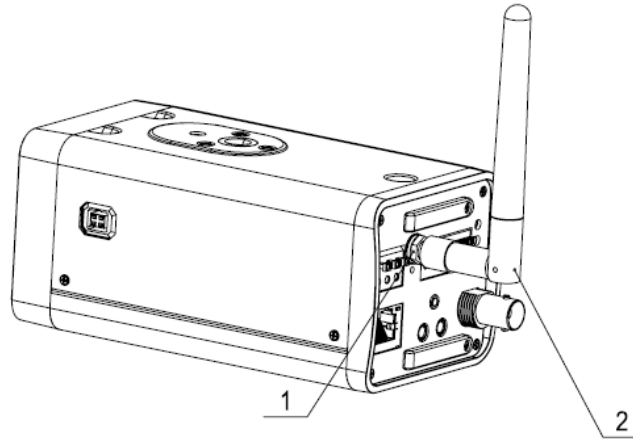

Figure 2-12 3G/Wifi antenna installation 3

2.4.2 Remove

Use your hands to hold the 3G/WIFI thread end and then turn according to the following figure. See Figure 2-13.

Now you can see the antenna is away from the thread. See Figure 2-14.

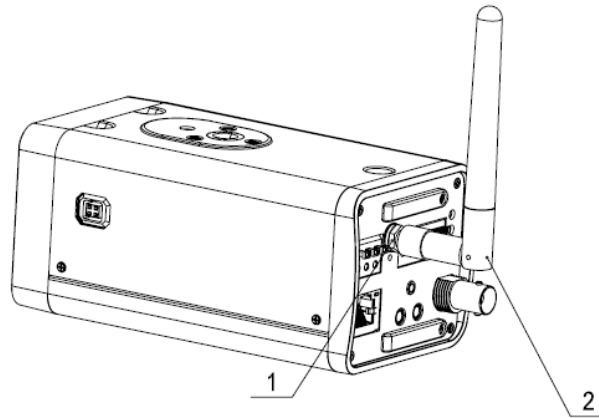

Figure 2-13 Remove 3G/Wifi antenna 1

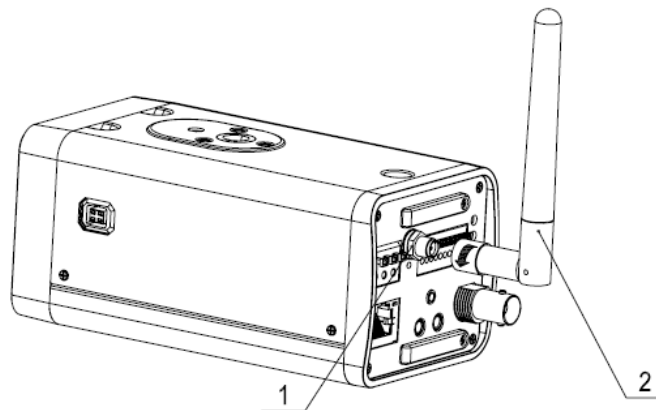

Figure 2-14 Remove 3G/Wifi antenna 2

Remove the 3G/WIFI antenna from the port of the rear panel. See Figure 2-15.

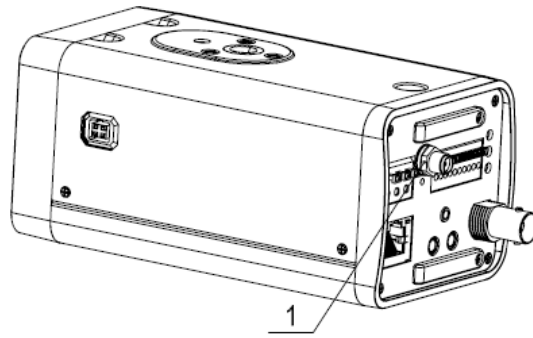

Figure 2-15 Remove 3G/Wifi antenna 3

2.5 I/O Port

2.5.1 Install and Remove Cable

Install Cable

Please follow the steps listed below to install the cable. See Figure 2-16.

Use the small slotted screwdriver to press the corresponding button of cable groove. Insert the cable into the groove and then release the screwdriver.

Remove Cable

Please follow the steps listed below to remove the cable.

Use the small slotted screwdriver to press the corresponding button of cable groove. Remove the cable out of the groove and then release the screwdriver.

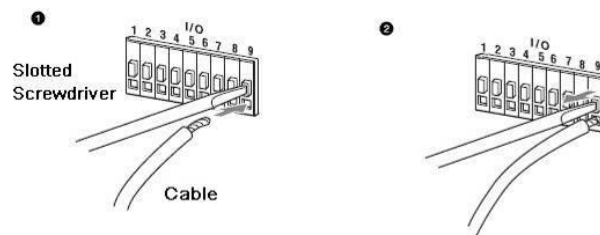

Figure 2-16 I/O port

If you want to modify the device IP address without logging in the device web interface, you can go to the configuration tool main interface to set.

In the configuration tool search interface (Figure 3-1), please select a device IP address and then double click it to open the login interface. Or you can select an IP address and then click the Login button to go to the login interface. See Figure 3-3.

In Figure 3-3, you can view device IP address, user name, password and port. Please modify the corresponding information to login.

Please note the port information here shall be identical with the port value you set in TCP port in Web Network interface. Otherwise, you cannot login the device.

If you are using device background upgrade port 3800 to login, other setups are all invalid.

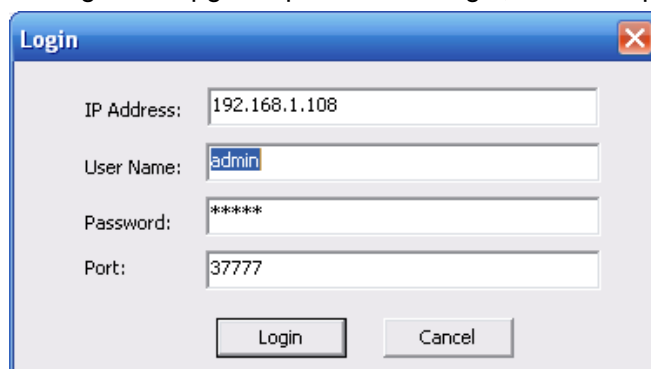

Figure 3-3 Login prompt

After you logged in, the configuration tool main interface is shown as below. See Figure 3-4.

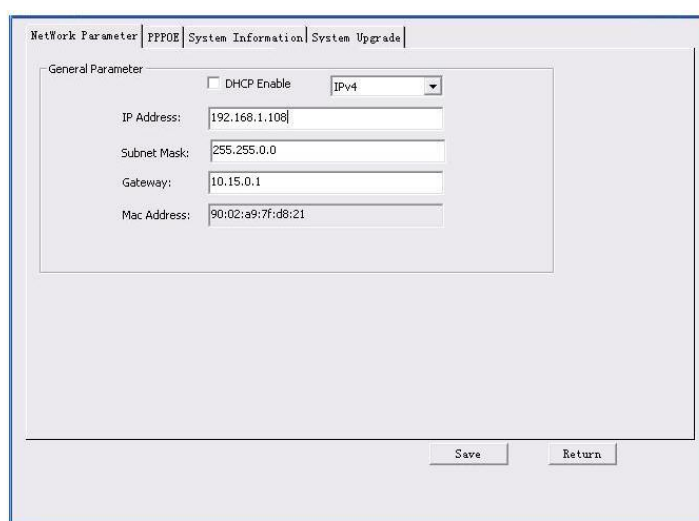

Figure 3-4 Main interface

For detailed information and operation instruction of the quick configuration tool, please refer to the *Quick Configuration Tool User's Manual* included in the resources CD.

4 Web Operation

This series network camera products support the Web access and management via PC. Web includes several modules: Monitor channel preview, system configuration, alarm and etc.

4.1 Network Connection

Please follow the steps listed below for network connection.

- Make sure the network camera has connected to the network properly.
- Please set the IP address, subnet mask and gateway of the PC and the network camera respectively. Network camera default IP address is 192.168.1.108. Subnet mask is 255.255.255.0. Gateway is 192.168.1.1
- Use order ping `***.***.***.***`(* network camera address) to check connection is OK or not.

4.2 Login and Main Interface

Open IE and input network camera address in the address bar. See Figure 4- 1.

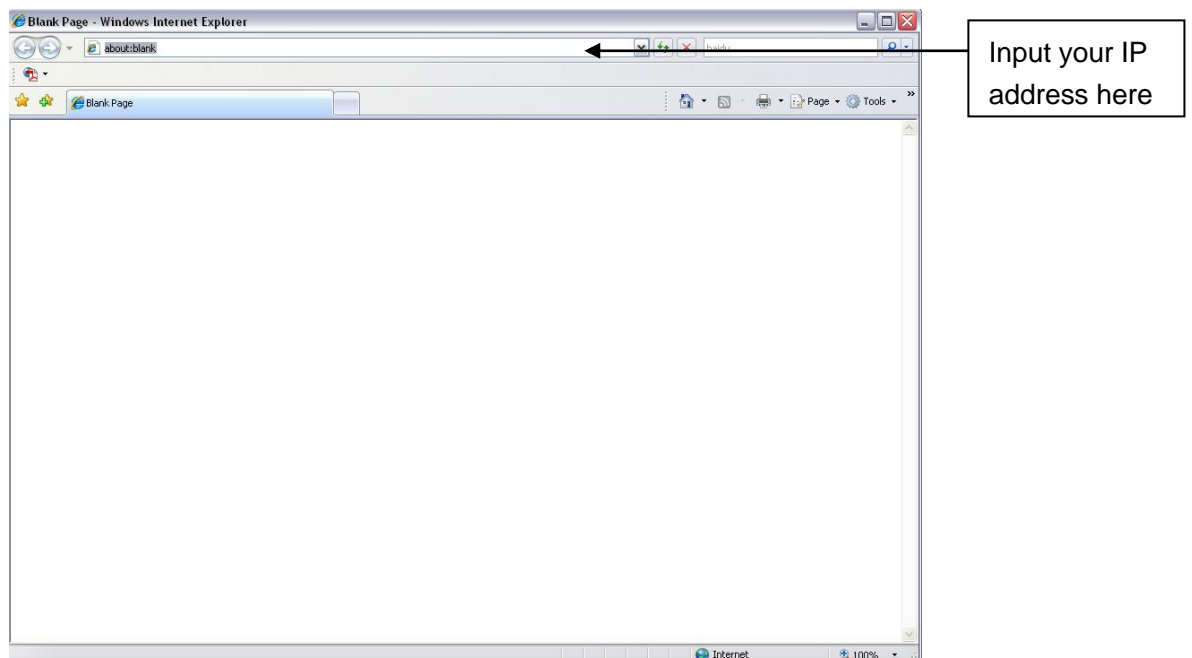

Figure 4- 1 IP address

The login interface is shown as below. See Figure 4- 2.

Please input your user name and password.

Default factory name is admin and password is admin.

Note: For security reasons, please modify your password after you first login.



Figure 4- 2 Web login

If it is your first time to login in, system pops up warning information to ask you whether install web plug-in or not after you logged in for one minute. For detailed plug-in installation, please refer to the Web Operation Manual included in the resource CD.

After you logged in, you can see the main window. See Figure 4- 3.

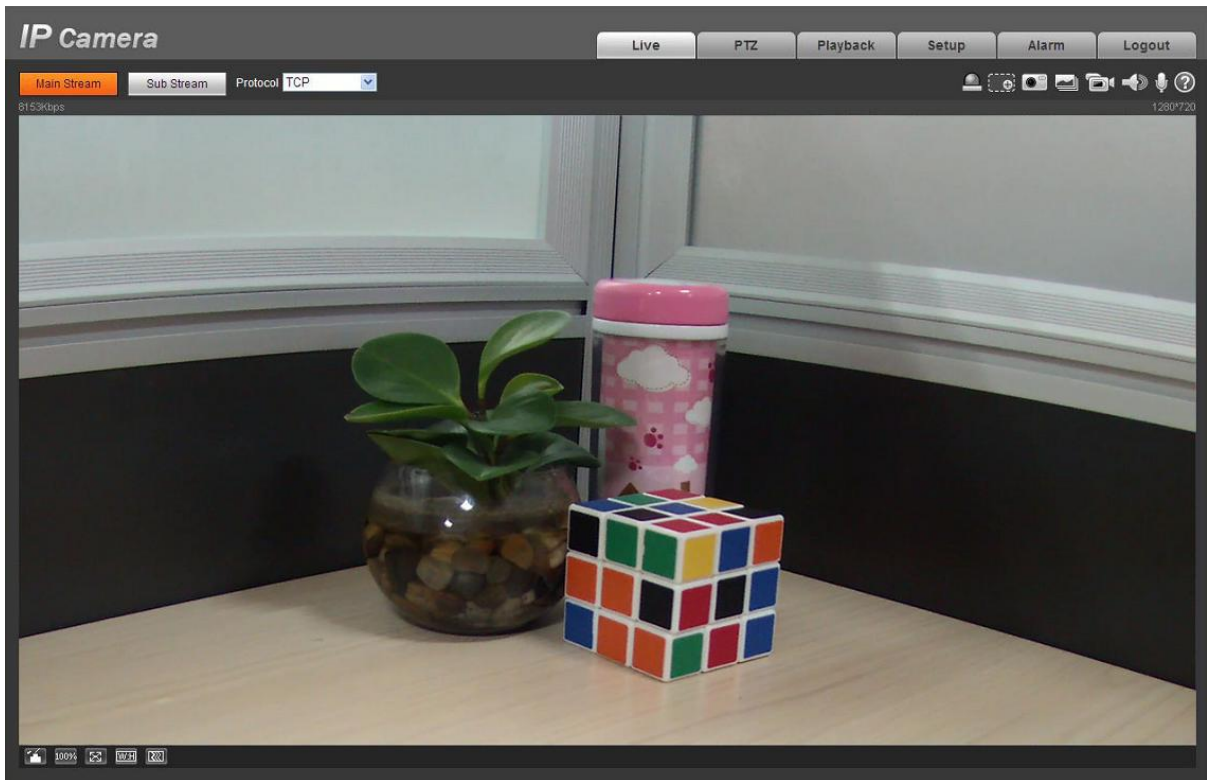

Figure 4- 3 Web monitoring window

Please refer to the Web Operation Manual included in the resource CD for detailed operation instruction.

Appendix Toxic or Hazardous Materials or Elements

Component Name	Toxic or Hazardous Materials or Elements					
	Pb	Hg	Cd	Cr VI	PBB	PBDE
Circuit Board Component	○	○	○	○	○	○
Case	○	○	○	○	○	○
Wire and Cable	○	○	○	○	○	○
Packing Components	○	○	○	○	○	○
Accessories	○	○	○	○	○	○

O: Indicates that the concentration of the hazardous substance in all homogeneous materials in the parts is below the relevant threshold of the SJ/T11363-2006 standard.

X: Indicates that the concentration of the hazardous substance of at least one of all homogeneous materials in the parts is above the relevant threshold of the SJ/T11363-2006 standard. During the environmental-friendly use period (EFUP) period, the toxic or hazardous substance or elements contained in products will not leak or mutate so that the use of these (substances or elements) will not result in any severe environmental pollution, any bodily injury or damage to any assets. The consumer is not authorized to process such kind of substances or elements, please return to the corresponding local authorities to process according to your local government statutes.

Note:

- **This quick start guide is for reference only.**
- **Slight difference may be found in user interface.**
- **All the designs and software here are subject to change without prior written notice.**
- **If there is any uncertainty or controversy, please refer to the final explanation of us.**
- **Please visit our website or contact your local service engineer for more information.**