

Pre-sale -- Choose a good LPR camera

A. How about the monitored vehicle speed?

The same algorithm running on the different platform will lead to different recognition efficiency. Such as : **low than 80 KMH, ITC237** can be optional. **Higher than 80KMH, ITC206/302/602** can be choice.

B. How many lanes to be monitor (Resolution)

Due to the pixel demand of lib for EU and CIS's plate, camera resolution should be chosen for different lane quantity. The width pixels of the plate must be at a required range, referred to table as below:

Plate Type	Region	Example	Width, pixels(Min)
Single-row	Russia and Kazakhstan, Armenia, Uzbekistan, Serbia		150
Double-row	Russia and Kazakhstan, Armenia, Uzbekistan, Serbia		100

			
Single-row	All other		130
Double-row	All other		70

For EU and CIS country, according to road width, physic plate size and plate pixel requirement,

1080P → 2 Lanes

4MP → 3 lanes

Right now Dahua offer the 2MP (ITC237, ITC206), 3MP(ITC302), 6.8MP (ITC602).

C. Monitor distance (Lens and IR)

How long the distance you want to monitor? (4~6 meters? 10~15 meters? 20~30 meters?...)

Different lens or IR distance required is up to the different of installation environment.

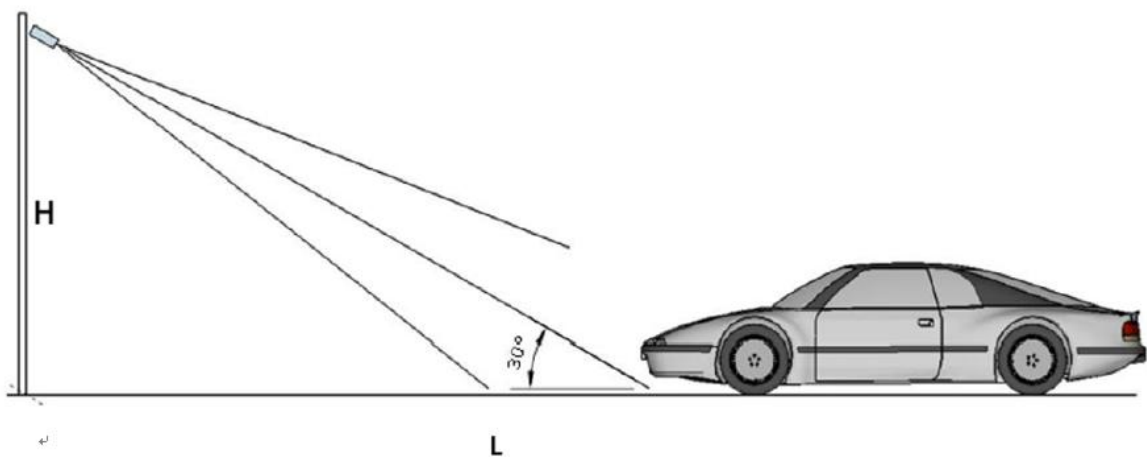

Collect the data on site:

1: What is the monitor range or capture distance for the vehicle?

After that, check the lens and IR range is enough or not ?

4~8 m, 1~2 lane, less than 80kmh: ITC237-PW1A, 4~8mm, built-in IR

8~35m, 1~2 lane, less than 80kmh : ITC237-PU1A, 5~50mm(Developing), built-in IR

20~30m, 1~2 lane, higher than 80kmh: ITC302, built-in IR

20~30m, 3 lane, higher than 80kmh: ITC602, built-in IR

After Sale –Get the best performance.

A. Installation

1. Monitor Distance 4~8m, 1 lane

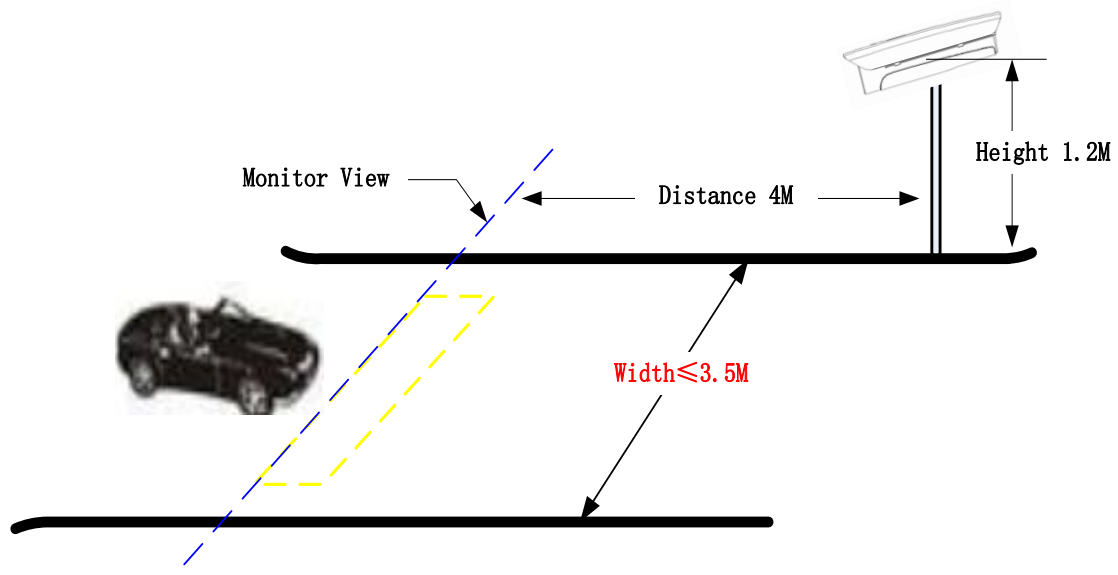

If just monitor 4~8 meters, the installation height of camera can be 1~2meter, (detection position means the distance from camera to the vehicle detected site)



2016-03-26 15:50:18.034 星期六 40度4mbian 车道1
车道1 浙AF236U





2. Monitor Distance 6~8m, 2 lane

If the monitor distance is too closed like 4 meter, if we want to see the vehicle plate number in second lane, will find the plate angle is too big, it's difficult for camera reading the plate.

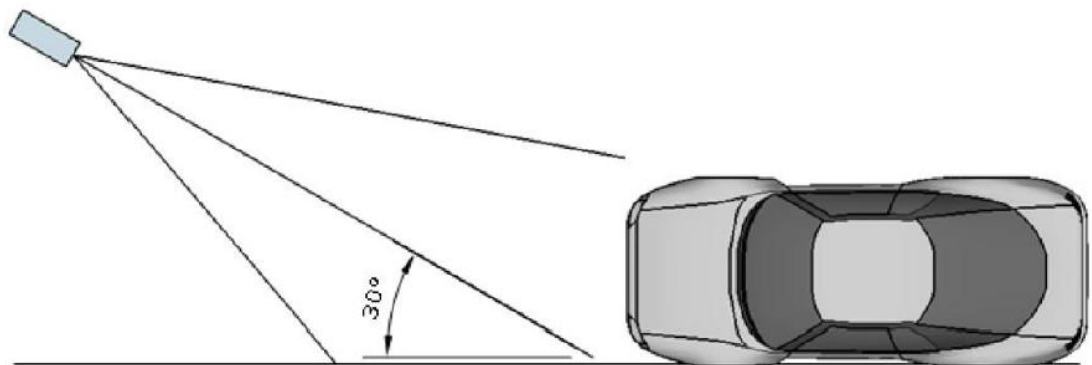

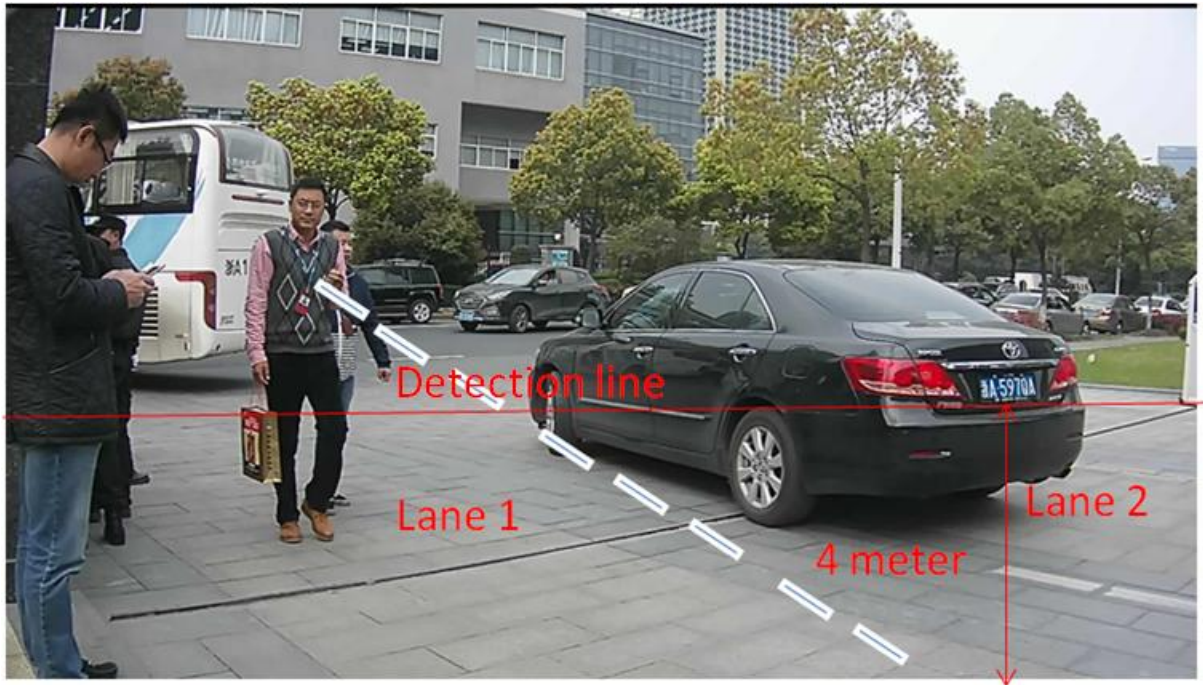

So right now the $H=5\text{m}$ due to the position of plate is on the second lane. if we make the monitor distance (L) longer like 8 meter, the plate angle will be smaller, but for pixels of plate maybe smaller, because the longer monitor distance, the view of camera will be bigger, so that the pixels of plate reduce.

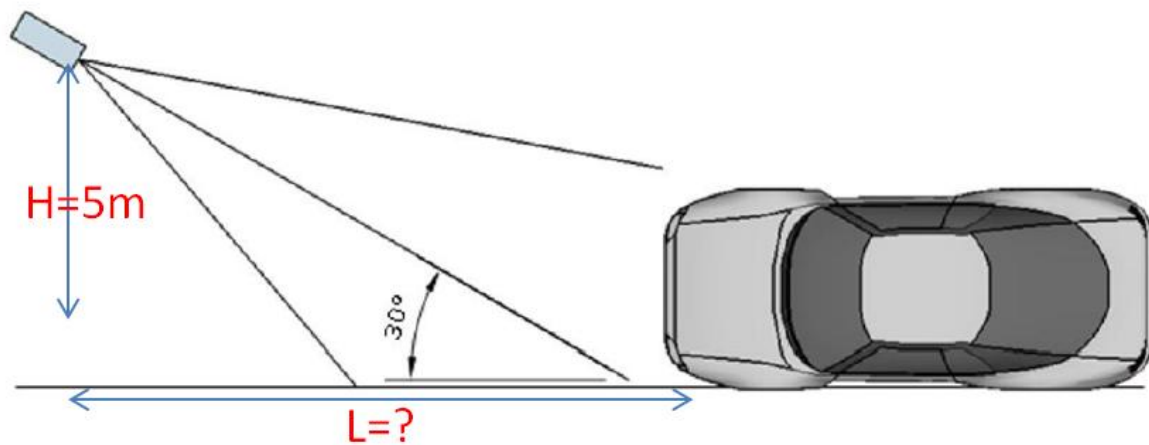

In this case, you can adjust the lens focus longer and make a longer detection area.

3. Monitor Distance 10~30m, 1~2 lane

Normally, if you want monitor the view 10~30 meter, the camera will be installed in height like 4~6 meter, the camera view need to be focused to traffic road you want see, otherwise, will be too huge view for software reading the plate pixel.

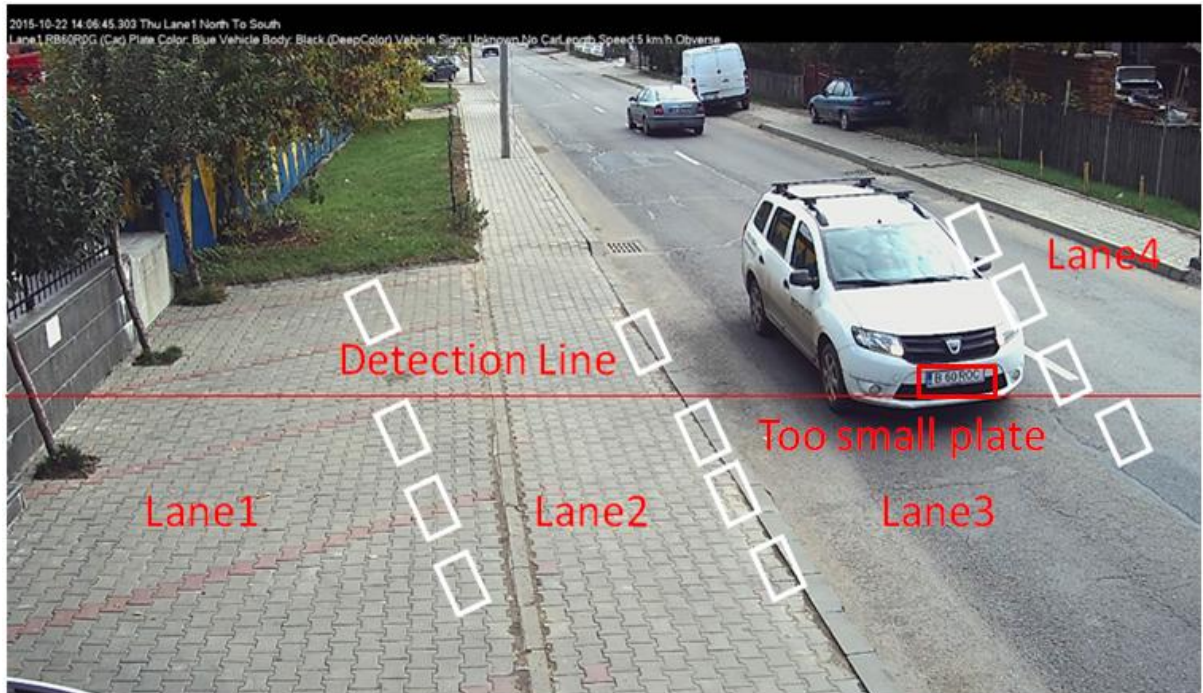

Adjust the angle of camera to shooting the road, and make the focus longer to see the plate clearly. Normally, keep the camera view as 2 lanes view is OK (If only need to monitor 1 lane, the camera focus can be adjusted to 1 lane- camera view)



The same notification, plate should be kept as horizontal line. You can turn the camera left / right side a litter upper or down according to the plate status.



4. Other notification:

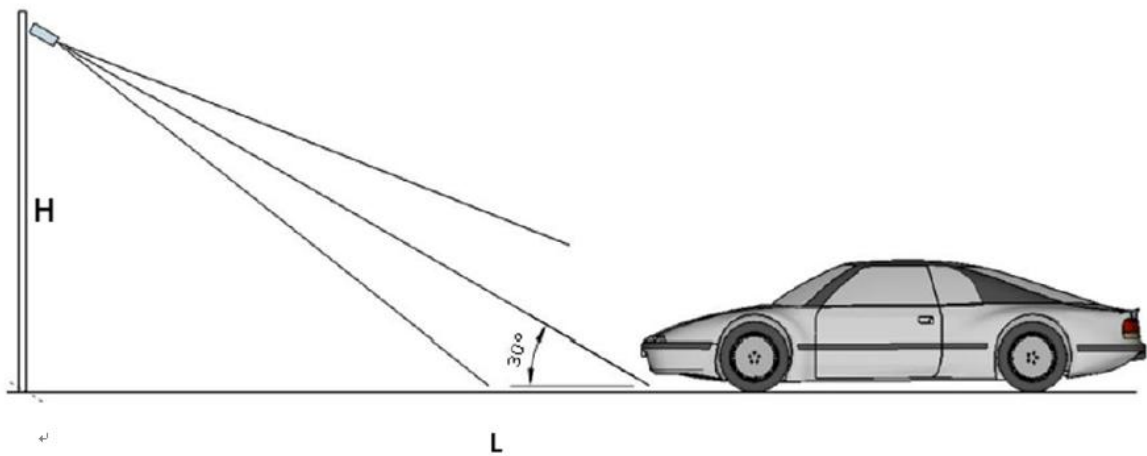

Vertical angle should not exceed 30 degree

L can not be too long, more sunlight will be involved in the camera view, influenced with the image of camera as below: (Also if the L too long, pixel of vehicle plate will be too smaller when the car drives into the detection area)

At the same time, L can not be too short, lead to the plate angle will be too big and the frame for the car passing into the detection area is not enough.

5. If you are two lanes solution, better way is that use a crossbar like below:

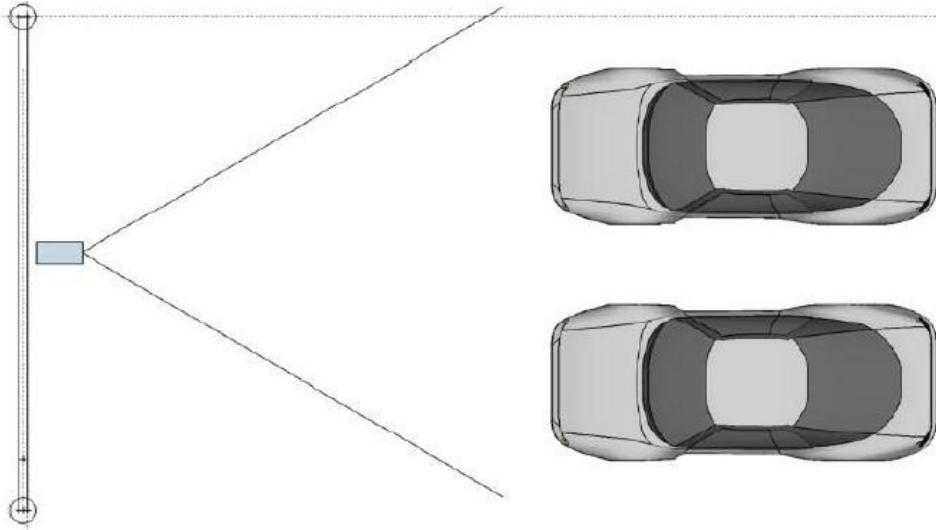

B. Easy configuration

After the installation, the view of camera should be confirmed, including the width of camera view, the position of camera shooting, level angle of camera, then adjust the parameter of image and focus the camera view.

1. Focus

The plate in this area should be clear enough for software to read. If the camera is motorized lens, choose the regional focus to make this area clear.

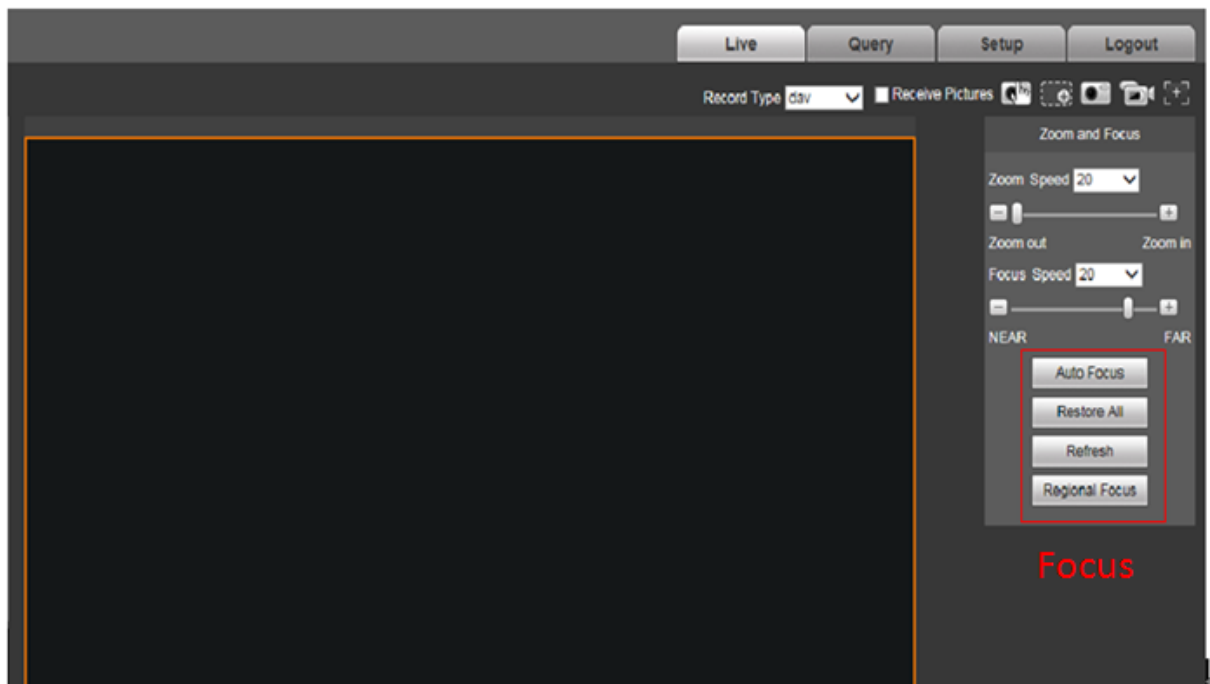



If the camera is focus manually, you can put a real plate on the camera view or focus according to the lane line of image quality at first step. Try to zoom in, focus the area you want, the result of focus will be best.

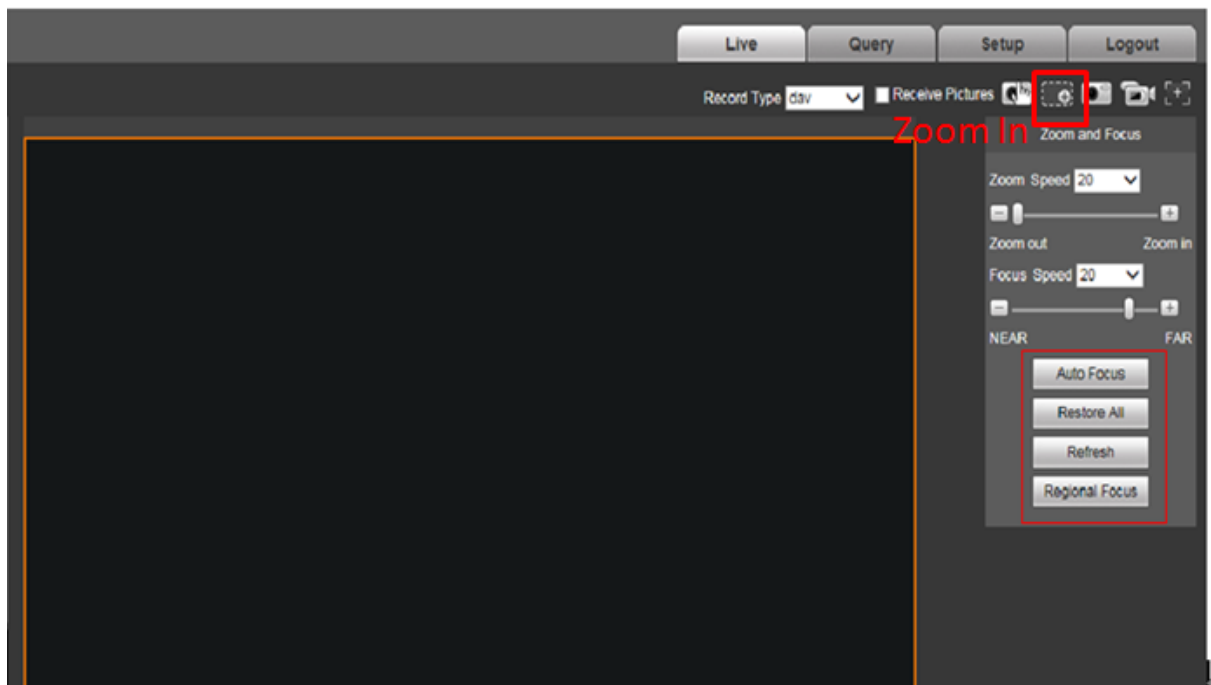

Remember click on the option "Receive Pictures", which means if the vehicle pictures has been took automatically, it will be freshly popup on the the square windows and been stored into the local pc.

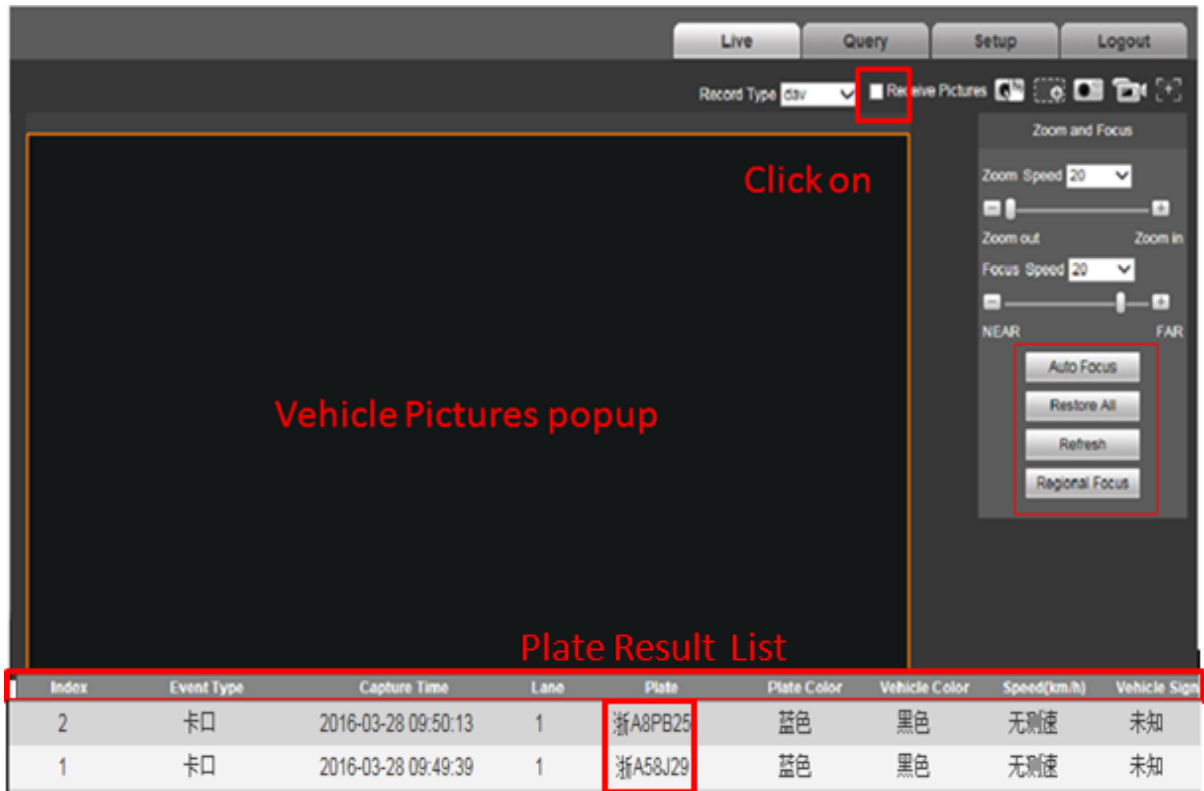

The result will be showed in the blank list under the picture windows.

2. Setup the image parameter

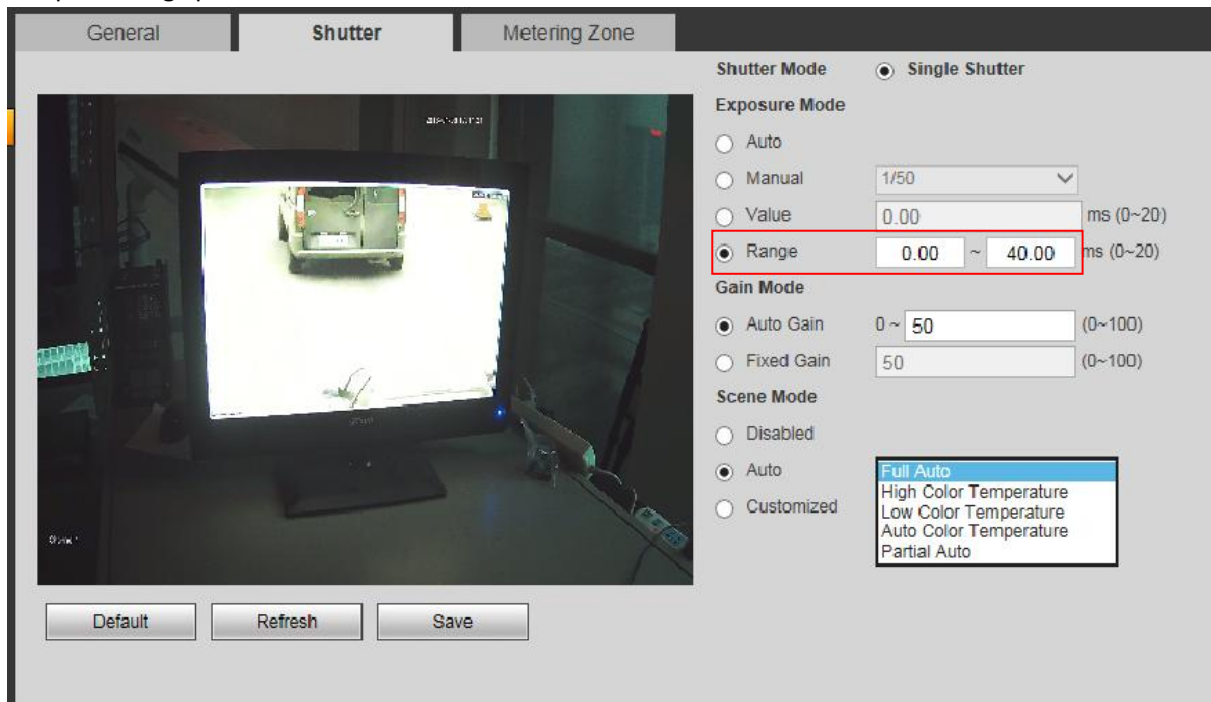

Exposure mode "Range: 0~5ms" for low speed.

ANPR Setting

1. Enable Event Type "ANPR", select the "Snap Direction"

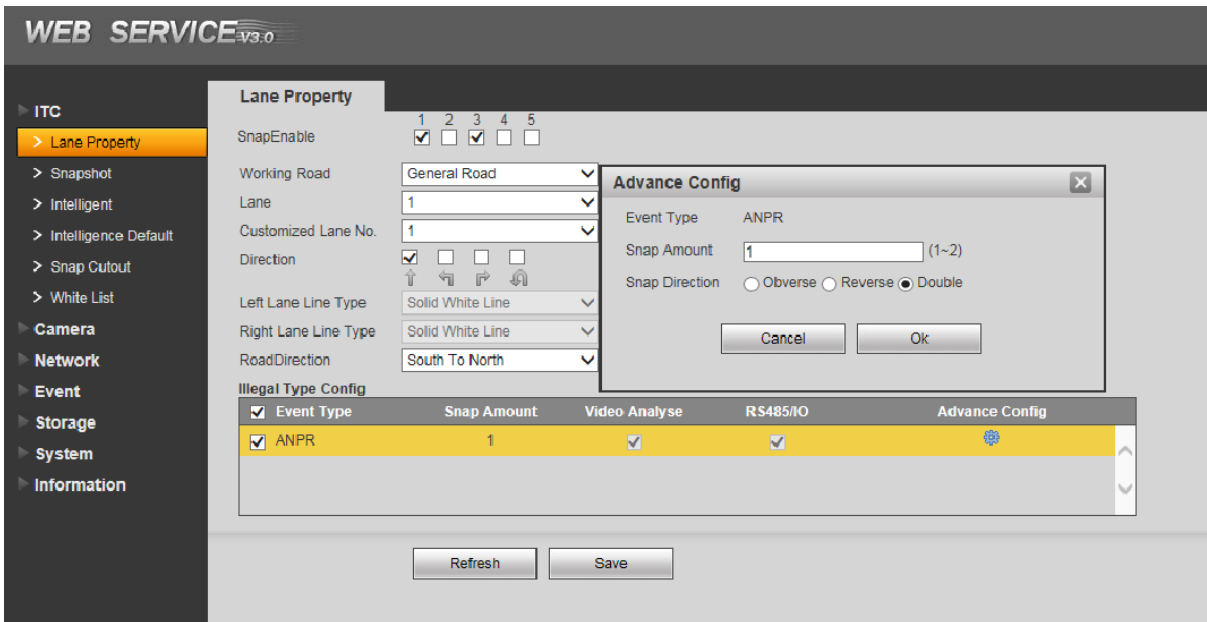

2. Draw a green square area(Occupy the half of view screen, which is 1MP based on 2MP image),make sure the plate enough pixels in the most of green square area. (such as: the minimum plate width pixel in the green square should be followed to recognition demand)

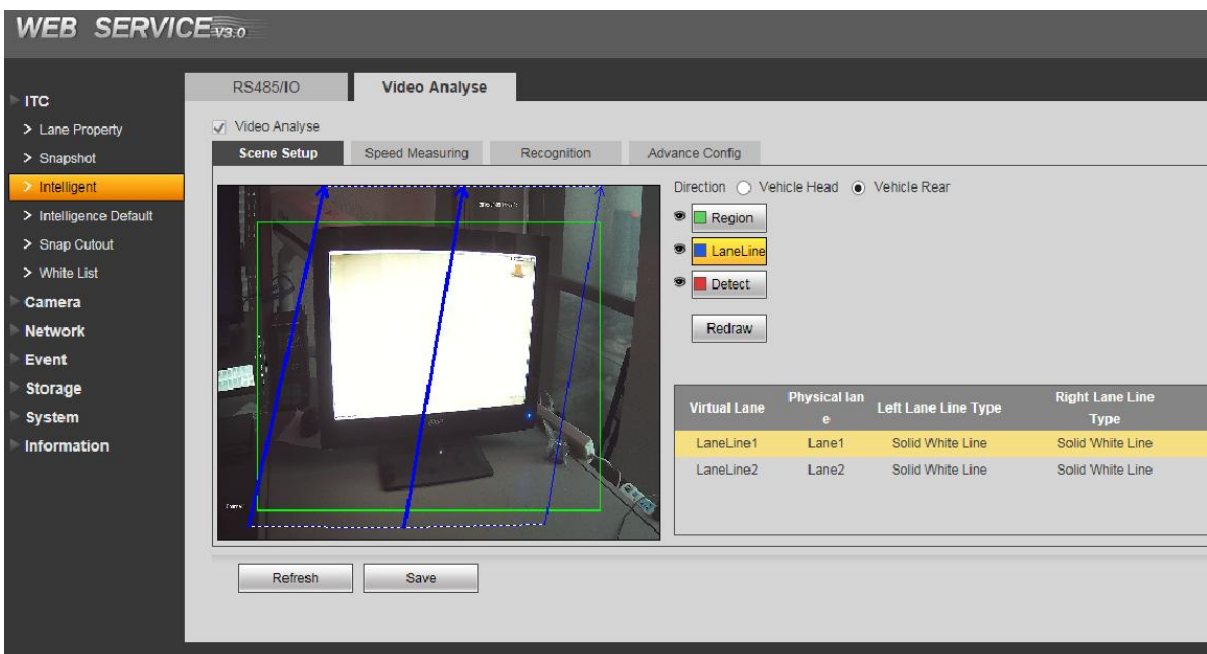

Blue line means the lane, you can draw it according to the real lane, 1 lane means drawing 2 lines, 2 lanes mean drawing 4 lines.

Red line means the snapshot position of detected vehicle(The distance between the real snapshot position to camera is for capture distance), if the car is driving approach, the red line can be as below:

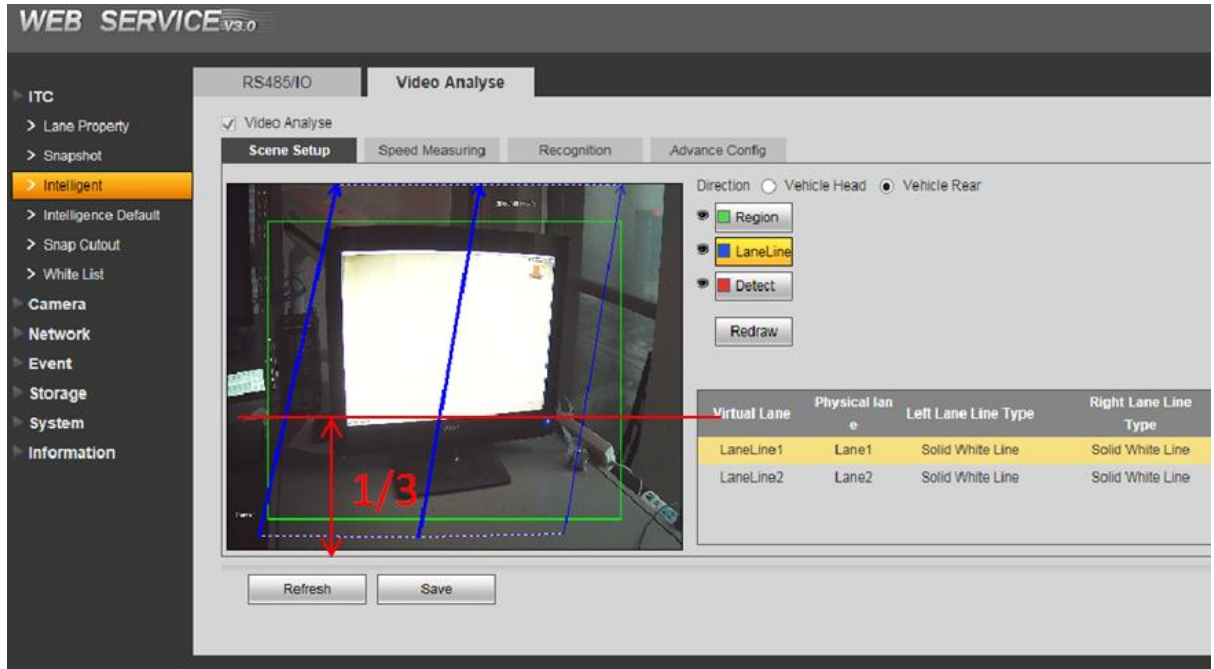

If the car is driving departure, red line can be:

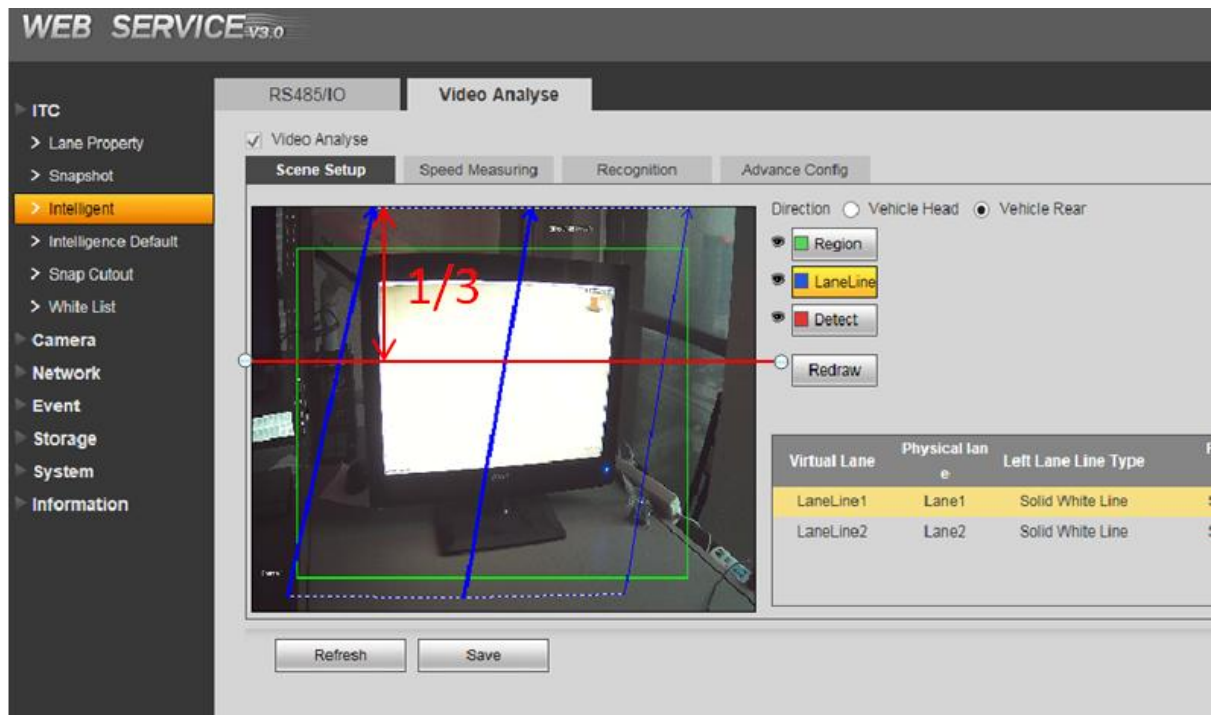

Mark: Vehicle Head, Vehicle Rear only means the direction of road lane.

C. Check the plate picture quality.

Every time if you find the camera recognition rate isn't good or don't work, pls give us the proof of plate picture no matter it's from the camera automatic snapshot or take it by manual hand.

1. Click on the option "Receive Picture", then black window will popup fresh picture of vehicle within

automatic video detection or manual snapshot. The reading plate result will be showed in the list.

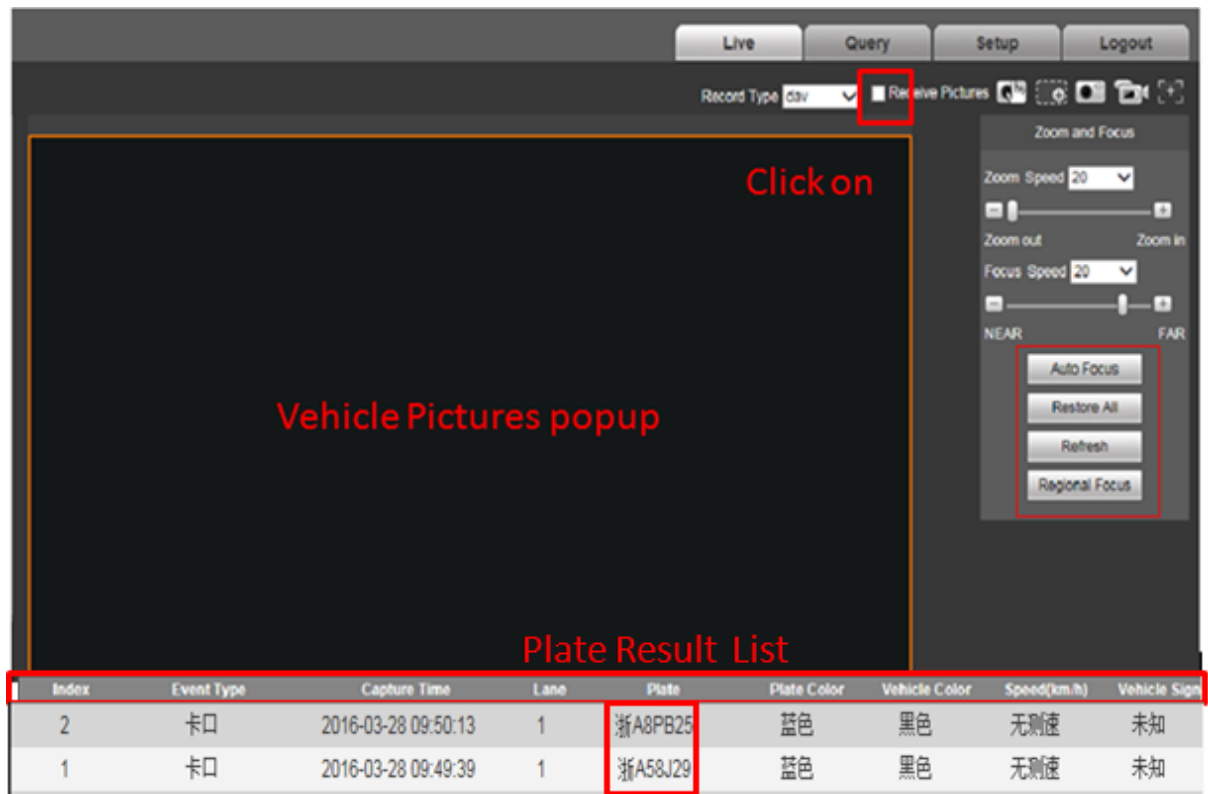

2. Or sometimes the camera view, firmware, vehicle speed is too difficult for reading the plate, the square window will not popup new pictures, in that case, you can click the button to take a picture by manual when the car coming into the detection area.

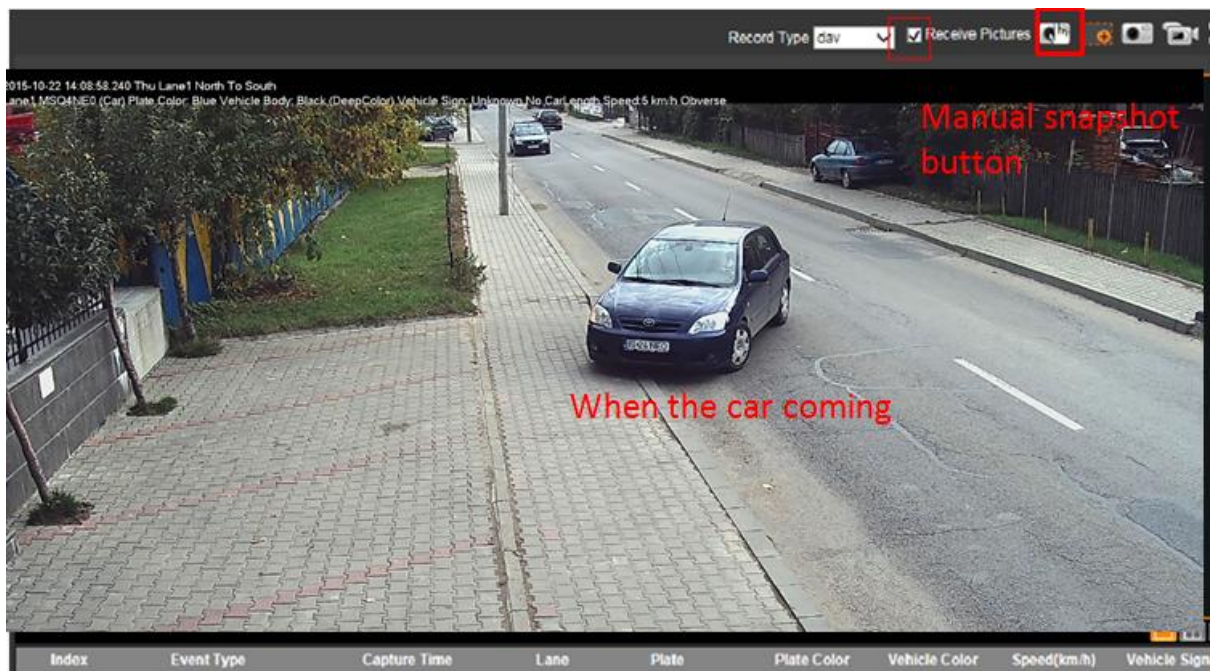

3. After get the picture from automatic video detection or manual snapshot, we can find the picture save as the path below, then you take out these pictures to check it yourself or by ours.

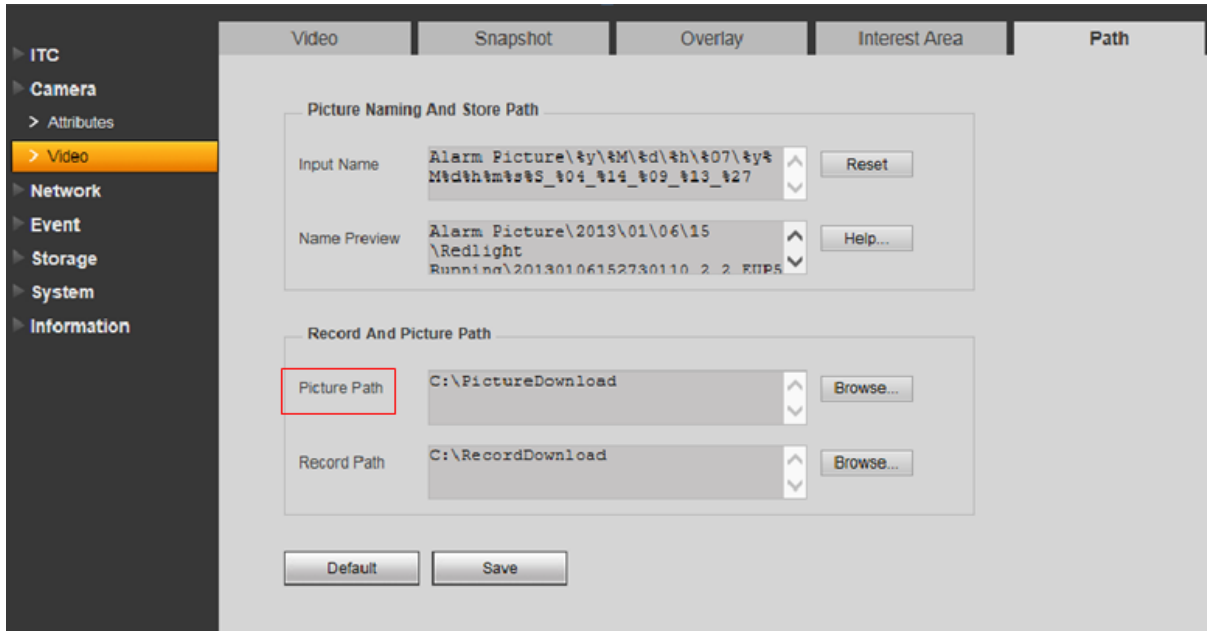

4. Check the clarity of plate image
Problem: not so clear like below



Answer: Focus again with electric zoom once again, or check the shutter value, adjust it less like 2.5 ~3 ms if the car speed is too fast.

5. Check the plate width pixel? --- **Open the paint software for the picture as above to check**

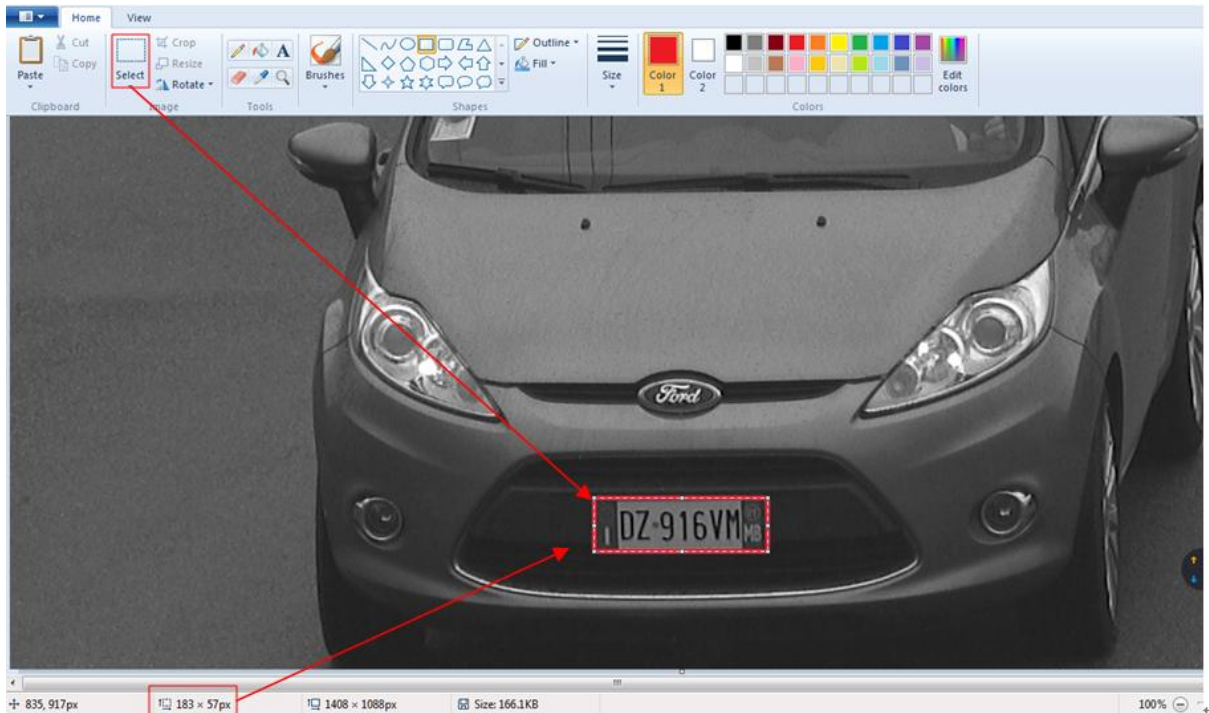

Mark: The width pixel should be followed as Part A of pre-sale

Problem: If the plate is smaller than the requirement, how to do it?

Answer: Please change the lens to longer one (Zoom in)

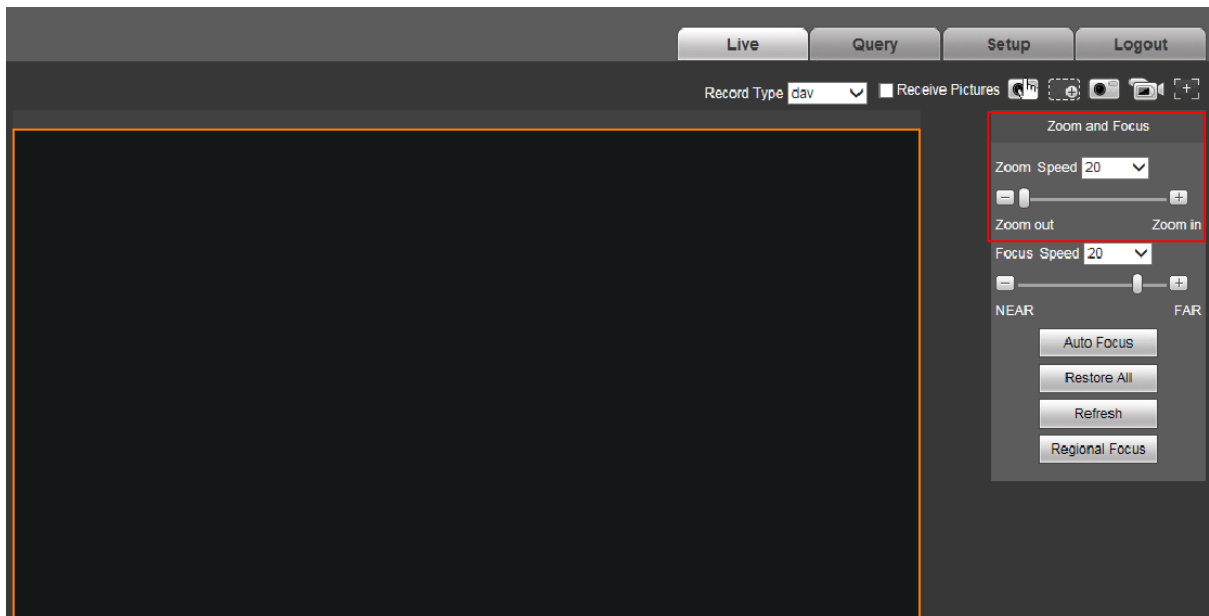

or if already get the limitation of lens, try to make the camera shooting distance shorter with the same focal length. (which means you can put the camera view a litter down, don't exceed the 30 degree)

5 Allowed Tilt

Should not exceed ± 5 Degree



Problem: If the plate angle is too big, how to do it?

Answer: Please make the camera left-side or right-side a little up to fix this angle. (With adjustable bracket of camera)

Horizontal angle should not exceed 30 degree (The camera view to the direction of vehicle movement)

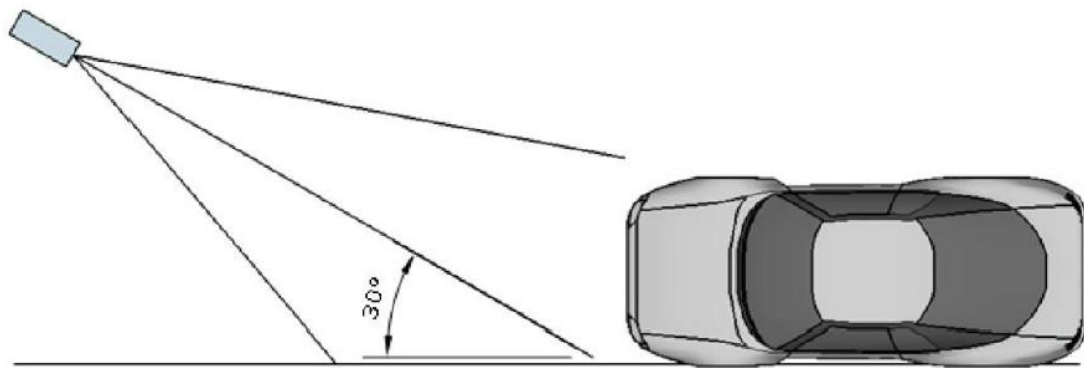

6 IR lighting

Not enough light



Answer: check the camera already configured to IR night mode. Or confirm the IR light if it is enough, maybe need a separate IR lamp because of the long distance.

Overexposed



Reduce the IR lamp power or shutter.

7. Depth of focus



Problem: If there is only a little part clear in the whole picture for plate, how to do it?

Answer:

- a. It's the reason for depth of focus. First, keep the lens, check if the plate in the detect area you want is clear enough, if you only use a part of the whole view to recognition, the other part is not your concern.
- b. Still meet the problem, try to focus in the different area point to balance the whole picture quality.
- c. If you use the adjustable lens, try to change to a fixed lens, which will be good at depth of focus.

8. Sunshine influence

Don't put the camera where sunshine maybe directly shooting, it will make the performance very bad during that time.

After confirm every plate pictures are good enough, the capture and recognition rate will be good enough.

D. Suggestion

1. Observe the picture quality and camera performance from daytime to night time, sometimes even you are good at night time or daytime, still will meet the problem at another time.
2. The installation foundation should be reliable, for example, if the pole is too weak, camera will be shaking all the time so that the performance is not good.

E. Good Picture Case

