



FHSST Authors

**The Free High School Science Texts:
Textbooks for High School Students
Studying the Sciences
Physics
Grades 10 - 12**

**Version 0
November 9, 2008**

Copyright 2007 "Free High School Science Texts"

Permission **is** granted to copy, distribute and/or modify this document under the terms of the GNU Free Documentation License, Version 1.2 or any later version published by the Free Software Foundation; with no Invariant Sections, no Front-Cover Texts, and no Back-Cover Texts. A copy of the license is included in the section entitled "GNU Free Documentation License".



STOP!!!!

Did you notice the **FREEDOMS** we've granted you?

Our copyright license is **different!** It grants freedoms rather than just imposing restrictions like all those other textbooks you probably own or use.

- We know people copy textbooks illegally but we would LOVE it if you copied our's - go ahead copy to your hearts content, **legally!**
- Publishers' revenue is generated by controlling the market, we don't want any money, go ahead, distribute our books far and wide - we DARE you!
- Ever wanted to change your textbook? Of course you have! Go ahead, change ours, make your own version, get your friends together, rip it apart and put it back together the way you like it. That's what we really want!
- Copy, modify, adapt, enhance, share, critique, adore, and contextualise. Do it all, do it with your colleagues, your friends, or alone but get involved! Together we can overcome the challenges our complex and diverse country presents.
- So what is the catch? The only thing you can't do is take this book, make a few changes and then tell others that they can't do the same with your changes. It's share and share-alike and we know you'll agree that is only fair.
- These books were written by volunteers who want to help support education, who want the facts to be freely available for teachers to copy, adapt and re-use. Thousands of hours went into making them and they are a gift to everyone in the education community.

FHSST Core Team

Mark Horner ; Samuel Halliday ; Sarah Blyth ; Rory Adams ; Spencer Wheaton

FHSST Editors

Jaynie Padayachee ; Joanne Boule ; Diana Mulcahy ; Annette Nell ; René Toerien ; Donovan
Whitfield

FHSST Contributors

Rory Adams ; Prashant Arora ; Richard Baxter ; Dr. Sarah Blyth ; Sebastian Bodenstein ;
Graeme Broster ; Richard Case ; Brett Cocks ; Tim Crombie ; Dr. Anne Dabrowski ; Laura
Daniels ; Sean Dobbs ; Fernando Durrell ; Dr. Dan Dwyer ; Frans van Eeden ; Giovanni
Franzoni ; Ingrid von Glehn ; Tamara von Glehn ; Lindsay Glesener ; Dr. Vanessa Godfrey ; Dr.
Johan Gonzalez ; Hemant Gopal ; Umeshree Govender ; Heather Gray ; Lynn Greeff ; Dr. Tom
Gutierrez ; Brooke Haag ; Kate Hadley ; Dr. Sam Halliday ; Asheena Hanuman ; Neil Hart ;
Nicholas Hatcher ; Dr. Mark Horner ; Robert Hovden ; Mfandaidza Hove ; Jennifer Hsieh ;
Clare Johnson ; Luke Jordan ; Tana Joseph ; Dr. Jennifer Klay ; Lara Kruger ; Sihle Kubheka ;
Andrew Kubik ; Dr. Marco van Leeuwen ; Dr. Anton Machacek ; Dr. Komal Maheshwari ;
Kosma von Maltitz ; Nicole Masureik ; John Mathew ; JoEllen McBride ; Nikolai Meures ;
Riana Meyer ; Jenny Miller ; Abdul Mirza ; Asogan Moodaly ; Jothi Moodley ; Nolene Naidu ;
Tyrone Negus ; Thomas O'Donnell ; Dr. Markus Oldenburg ; Dr. Jaynie Padayachee ;
Nicolette Pekeur ; Sirika Pillay ; Jacques Plaut ; Andrea Prinsloo ; Joseph Raimondo ; Sanya
Rajani ; Prof. Sergey Rakityansky ; Alastair Ramlakan ; Razvan Remsing ; Max Richter ; Sean
Riddle ; Evan Robinson ; Dr. Andrew Rose ; Bianca Ruddy ; Katie Russell ; Duncan Scott ;
Helen Seals ; Ian Sherratt ; Roger Sieloff ; Bradley Smith ; Greg Solomon ; Mike Stringer ;
Shen Tian ; Robert Torregrosa ; Jimmy Tseng ; Helen Waugh ; Dr. Dawn Webber ; Michelle
Wen ; Dr. Alexander Wetzler ; Dr. Spencer Wheaton ; Vivian White ; Dr. Gerald Wigger ;
Harry Wiggins ; Wendy Williams ; Julie Wilson ; Andrew Wood ; Emma Wormauld ; Sahal
Yacoob ; Jean Youssef

Contributors and editors have made a sincere effort to produce an accurate and useful resource.
Should you have suggestions, find mistakes or be prepared to donate material for inclusion,
please don't hesitate to contact us. We intend to work with all who are willing to help make
this a continuously evolving resource!

www.fhsst.org

Contents

I	Introduction	1
1	What is Physics?	3
II	Grade 10 - Physics	5
2	Units	9
2.1	Introduction	9
2.2	Unit Systems	9
2.2.1	SI Units	9
2.2.2	The Other Systems of Units	10
2.3	Writing Units as Words or Symbols	10
2.4	Combinations of SI Base Units	12
2.5	Rounding, Scientific Notation and Significant Figures	12
2.5.1	Rounding Off	12
2.5.2	Error Margins	13
2.5.3	Scientific Notation	13
2.5.4	Significant Figures	15
2.6	Prefixes of Base Units	15
2.7	The Importance of Units	17
2.8	How to Change Units	17
2.8.1	Two other useful conversions	19
2.9	A sanity test	19
2.10	Summary	19
2.11	End of Chapter Exercises	21
3	Motion in One Dimension - Grade 10	23
3.1	Introduction	23
3.2	Reference Point, Frame of Reference and Position	23
3.2.1	Frames of Reference	23
3.2.2	Position	25
3.3	Displacement and Distance	28
3.3.1	Interpreting Direction	29
3.3.2	Differences between Distance and Displacement	29
3.4	Speed, Average Velocity and Instantaneous Velocity	31

3.4.1	Differences between Speed and Velocity	35
3.5	Acceleration	38
3.6	Description of Motion	39
3.6.1	Stationary Object	40
3.6.2	Motion at Constant Velocity	41
3.6.3	Motion at Constant Acceleration	46
3.7	Summary of Graphs	48
3.8	Worked Examples	49
3.9	Equations of Motion	54
3.9.1	Finding the Equations of Motion	54
3.10	Applications in the Real-World	59
3.11	Summary	61
3.12	End of Chapter Exercises: Motion in One Dimension	62
4	Gravity and Mechanical Energy - Grade 10	67
4.1	Weight	67
4.1.1	Differences between Mass and Weight	68
4.2	Acceleration due to Gravity	69
4.2.1	Gravitational Fields	69
4.2.2	Free fall	69
4.3	Potential Energy	73
4.4	Kinetic Energy	75
4.4.1	Checking units	77
4.5	Mechanical Energy	78
4.5.1	Conservation of Mechanical Energy	78
4.5.2	Using the Law of Conservation of Energy	79
4.6	Energy graphs	82
4.7	Summary	83
4.8	End of Chapter Exercises: Gravity and Mechanical Energy	84
5	Transverse Pulses - Grade 10	87
5.1	Introduction	87
5.2	What is a <i>medium</i> ?	87
5.3	What is a <i>pulse</i> ?	87
5.3.1	Pulse Length and Amplitude	88
5.3.2	Pulse Speed	89
5.4	Graphs of Position and Velocity	90
5.4.1	Motion of a Particle of the Medium	90
5.4.2	Motion of the Pulse	92
5.5	Transmission and Reflection of a Pulse at a Boundary	96
5.6	Reflection of a Pulse from Fixed and Free Ends	97
5.6.1	Reflection of a Pulse from a Fixed End	97

5.6.2	Reflection of a Pulse from a Free End	98
5.7	Superposition of Pulses	99
5.8	Exercises - Transverse Pulses	102
6	Transverse Waves - Grade 10	105
6.1	Introduction	105
6.2	What is a <i>transverse wave</i> ?	105
6.2.1	Peaks and Troughs	106
6.2.2	Amplitude and Wavelength	107
6.2.3	Points in Phase	109
6.2.4	Period and Frequency	110
6.2.5	Speed of a Transverse Wave	111
6.3	Graphs of Particle Motion	115
6.4	Standing Waves and Boundary Conditions	118
6.4.1	Reflection of a Transverse Wave from a Fixed End	118
6.4.2	Reflection of a Transverse Wave from a Free End	118
6.4.3	Standing Waves	118
6.4.4	Nodes and anti-nodes	122
6.4.5	Wavelengths of Standing Waves with Fixed and Free Ends	122
6.4.6	Superposition and Interference	125
6.5	Summary	127
6.6	Exercises	127
7	Geometrical Optics - Grade 10	129
7.1	Introduction	129
7.2	Light Rays	129
7.2.1	Shadows	132
7.2.2	Ray Diagrams	132
7.3	Reflection	132
7.3.1	Terminology	133
7.3.2	Law of Reflection	133
7.3.3	Types of Reflection	135
7.4	Refraction	137
7.4.1	Refractive Index	139
7.4.2	Snell's Law	139
7.4.3	Apparent Depth	143
7.5	Mirrors	146
7.5.1	Image Formation	146
7.5.2	Plane Mirrors	147
7.5.3	Ray Diagrams	148
7.5.4	Spherical Mirrors	150
7.5.5	Concave Mirrors	150

7.5.6	Convex Mirrors	153
7.5.7	Summary of Properties of Mirrors	154
7.5.8	Magnification	154
7.6	Total Internal Reflection and Fibre Optics	156
7.6.1	Total Internal Reflection	156
7.6.2	Fibre Optics	161
7.7	Summary	163
7.8	Exercises	164
8	Magnetism - Grade 10	167
8.1	Introduction	167
8.2	Magnetic fields	167
8.3	Permanent magnets	169
8.3.1	The poles of permanent magnets	169
8.3.2	Magnetic attraction and repulsion	169
8.3.3	Representing magnetic fields	170
8.4	The compass and the earth's magnetic field	173
8.4.1	The earth's magnetic field	175
8.5	Summary	175
8.6	End of chapter exercises	176
9	Electrostatics - Grade 10	177
9.1	Introduction	177
9.2	Two kinds of charge	177
9.3	Unit of charge	177
9.4	Conservation of charge	177
9.5	Force between Charges	178
9.6	Conductors and insulators	181
9.6.1	The electroscope	182
9.7	Attraction between charged and uncharged objects	183
9.7.1	Polarisation of Insulators	183
9.8	Summary	184
9.9	End of chapter exercise	184
10	Electric Circuits - Grade 10	187
10.1	Electric Circuits	187
10.1.1	Closed circuits	187
10.1.2	Representing electric circuits	188
10.2	Potential Difference	192
10.2.1	Potential Difference	192
10.2.2	Potential Difference and Parallel Resistors	193
10.2.3	Potential Difference and Series Resistors	194
10.2.4	Ohm's Law	194

10.2.5 EMF	195
10.3 Current	198
10.3.1 Flow of Charge	198
10.3.2 Current	198
10.3.3 Series Circuits	199
10.3.4 Parallel Circuits	200
10.4 Resistance	202
10.4.1 What causes resistance?	202
10.4.2 Resistors in electric circuits	202
10.5 Instruments to Measure voltage, current and resistance	204
10.5.1 Voltmeter	204
10.5.2 Ammeter	204
10.5.3 Ohmmeter	204
10.5.4 Meters Impact on Circuit	205
10.6 Exercises - Electric circuits	205
III Grade 11 - Physics	209
11 Vectors	211
11.1 Introduction	211
11.2 Scalars and Vectors	211
11.3 Notation	211
11.3.1 Mathematical Representation	212
11.3.2 Graphical Representation	212
11.4 Directions	212
11.4.1 Relative Directions	212
11.4.2 Compass Directions	213
11.4.3 Bearing	213
11.5 Drawing Vectors	214
11.6 Mathematical Properties of Vectors	215
11.6.1 Adding Vectors	215
11.6.2 Subtracting Vectors	217
11.6.3 Scalar Multiplication	218
11.7 Techniques of Vector Addition	218
11.7.1 Graphical Techniques	218
11.7.2 Algebraic Addition and Subtraction of Vectors	223
11.8 Components of Vectors	228
11.8.1 Vector addition using components	231
11.8.2 Summary	235
11.8.3 End of chapter exercises: Vectors	236
11.8.4 End of chapter exercises: Vectors - Long questions	237

12 Force, Momentum and Impulse - Grade 11	239
12.1 Introduction	239
12.2 Force	239
12.2.1 What is a <i>force</i> ?	239
12.2.2 Examples of Forces in Physics	240
12.2.3 Systems and External Forces	241
12.2.4 Force Diagrams	242
12.2.5 Free Body Diagrams	243
12.2.6 Finding the Resultant Force	244
12.2.7 Exercise	246
12.3 Newton's Laws	246
12.3.1 Newton's First Law	247
12.3.2 Newton's Second Law of Motion	249
12.3.3 Exercise	261
12.3.4 Newton's Third Law of Motion	263
12.3.5 Exercise	267
12.3.6 Different types of forces	268
12.3.7 Exercise	275
12.3.8 Forces in equilibrium	276
12.3.9 Exercise	279
12.4 Forces between Masses	282
12.4.1 Newton's Law of Universal Gravitation	282
12.4.2 Comparative Problems	284
12.4.3 Exercise	286
12.5 Momentum and Impulse	287
12.5.1 Vector Nature of Momentum	290
12.5.2 Exercise	291
12.5.3 Change in Momentum	291
12.5.4 Exercise	293
12.5.5 Newton's Second Law revisited	293
12.5.6 Impulse	294
12.5.7 Exercise	296
12.5.8 Conservation of Momentum	297
12.5.9 Physics in Action: Impulse	300
12.5.10 Exercise	301
12.6 Torque and Levers	302
12.6.1 Torque	302
12.6.2 Mechanical Advantage and Levers	305
12.6.3 Classes of levers	307
12.6.4 Exercise	308
12.7 Summary	309
12.8 End of Chapter exercises	310

13 Geometrical Optics - Grade 11	327
13.1 Introduction	327
13.2 Lenses	327
13.2.1 Converging Lenses	329
13.2.2 Diverging Lenses	340
13.2.3 Summary of Image Properties	343
13.3 The Human Eye	344
13.3.1 Structure of the Eye	345
13.3.2 Defects of Vision	346
13.4 Gravitational Lenses	347
13.5 Telescopes	347
13.5.1 Refracting Telescopes	347
13.5.2 Reflecting Telescopes	348
13.5.3 Southern African Large Telescope	348
13.6 Microscopes	349
13.7 Summary	351
13.8 Exercises	352
14 Longitudinal Waves - Grade 11	355
14.1 Introduction	355
14.2 What is a <i>longitudinal wave</i> ?	355
14.3 Characteristics of Longitudinal Waves	356
14.3.1 Compression and Rarefaction	356
14.3.2 Wavelength and Amplitude	357
14.3.3 Period and Frequency	357
14.3.4 Speed of a Longitudinal Wave	358
14.4 Graphs of Particle Position, Displacement, Velocity and Acceleration	359
14.5 Sound Waves	360
14.6 Seismic Waves	361
14.7 Summary - Longitudinal Waves	361
14.8 Exercises - Longitudinal Waves	362
15 Sound - Grade 11	363
15.1 Introduction	363
15.2 Characteristics of a Sound Wave	363
15.2.1 Pitch	364
15.2.2 Loudness	364
15.2.3 Tone	364
15.3 Speed of Sound	365
15.4 Physics of the Ear and Hearing	365
15.4.1 Intensity of Sound	366
15.5 Ultrasound	367

15.6 SONAR	368
15.6.1 Echolocation	368
15.7 Summary	369
15.8 Exercises	369
16 The Physics of Music - Grade 11	373
16.1 Introduction	373
16.2 Standing Waves in String Instruments	373
16.3 Standing Waves in Wind Instruments	377
16.4 Resonance	382
16.5 Music and Sound Quality	384
16.6 Summary - The Physics of Music	385
16.7 End of Chapter Exercises	386
17 Electrostatics - Grade 11	387
17.1 Introduction	387
17.2 Forces between charges - Coulomb's Law	387
17.3 Electric field around charges	392
17.3.1 Electric field lines	393
17.3.2 Positive charge acting on a test charge	393
17.3.3 Combined charge distributions	394
17.3.4 Parallel plates	397
17.4 Electrical potential energy and potential	400
17.4.1 Electrical potential	400
17.4.2 Real-world application: lightning	402
17.5 Capacitance and the parallel plate capacitor	403
17.5.1 Capacitors and capacitance	403
17.5.2 Dielectrics	404
17.5.3 Physical properties of the capacitor and capacitance	404
17.5.4 Electric field in a capacitor	405
17.6 Capacitor as a circuit device	406
17.6.1 A capacitor in a circuit	406
17.6.2 Real-world applications: capacitors	407
17.7 Summary	407
17.8 Exercises - Electrostatics	407
18 Electromagnetism - Grade 11	413
18.1 Introduction	413
18.2 Magnetic field associated with a current	413
18.2.1 Real-world applications	418
18.3 Current induced by a changing magnetic field	420
18.3.1 Real-life applications	422
18.4 Transformers	423

18.4.1 Real-world applications	425
18.5 Motion of a charged particle in a magnetic field	425
18.5.1 Real-world applications	426
18.6 Summary	427
18.7 End of chapter exercises	427
19 Electric Circuits - Grade 11	429
19.1 Introduction	429
19.2 Ohm's Law	429
19.2.1 Definition of Ohm's Law	429
19.2.2 Ohmic and non-ohmic conductors	431
19.2.3 Using Ohm's Law	432
19.3 Resistance	433
19.3.1 Equivalent resistance	433
19.3.2 Use of Ohm's Law in series and parallel Circuits	438
19.3.3 Batteries and internal resistance	440
19.4 Series and parallel networks of resistors	442
19.5 Wheatstone bridge	445
19.6 Summary	447
19.7 End of chapter exercise	447
20 Electronic Properties of Matter - Grade 11	451
20.1 Introduction	451
20.2 Conduction	451
20.2.1 Metals	453
20.2.2 Insulator	453
20.2.3 Semi-conductors	454
20.3 Intrinsic Properties and Doping	454
20.3.1 Surplus	455
20.3.2 Deficiency	455
20.4 The p-n junction	457
20.4.1 Differences between p- and n-type semi-conductors	457
20.4.2 The p-n Junction	457
20.4.3 Unbiased	457
20.4.4 Forward biased	457
20.4.5 Reverse biased	458
20.4.6 Real-World Applications of Semiconductors	458
20.5 End of Chapter Exercises	459
IV Grade 12 - Physics	461
21 Motion in Two Dimensions - Grade 12	463
21.1 Introduction	463

21.2 Vertical Projectile Motion	463
21.2.1 Motion in a Gravitational Field	463
21.2.2 Equations of Motion	464
21.2.3 Graphs of Vertical Projectile Motion	467
21.3 Conservation of Momentum in Two Dimensions	475
21.4 Types of Collisions	480
21.4.1 Elastic Collisions	480
21.4.2 Inelastic Collisions	485
21.5 Frames of Reference	490
21.5.1 Introduction	490
21.5.2 What is a <i>frame of reference</i> ?	491
21.5.3 Why are frames of reference important?	491
21.5.4 Relative Velocity	491
21.6 Summary	494
21.7 End of chapter exercises	495
22 Mechanical Properties of Matter - Grade 12	503
22.1 Introduction	503
22.2 Deformation of materials	503
22.2.1 Hooke's Law	503
22.2.2 Deviation from Hooke's Law	506
22.3 Elasticity, plasticity, fracture, creep	508
22.3.1 Elasticity and plasticity	508
22.3.2 Fracture, creep and fatigue	508
22.4 Failure and strength of materials	509
22.4.1 The properties of matter	509
22.4.2 Structure and failure of materials	509
22.4.3 Controlling the properties of materials	509
22.4.4 Steps of Roman Swordsmithing	510
22.5 Summary	511
22.6 End of chapter exercise	511
23 Work, Energy and Power - Grade 12	513
23.1 Introduction	513
23.2 Work	513
23.3 Energy	519
23.3.1 External and Internal Forces	519
23.3.2 Capacity to do Work	520
23.4 Power	525
23.5 Important Equations and Quantities	529
23.6 End of Chapter Exercises	529

24 Doppler Effect - Grade 12	533
24.1 Introduction	533
24.2 The Doppler Effect with Sound and Ultrasound	533
24.2.1 Ultrasound and the Doppler Effect	537
24.3 The Doppler Effect with Light	537
24.3.1 The Expanding Universe	538
24.4 Summary	539
24.5 End of Chapter Exercises	539
25 Colour - Grade 12	541
25.1 Introduction	541
25.2 Colour and Light	541
25.2.1 Dispersion of white light	544
25.3 Addition and Subtraction of Light	544
25.3.1 Additive Primary Colours	544
25.3.2 Subtractive Primary Colours	545
25.3.3 Complementary Colours	546
25.3.4 Perception of Colour	546
25.3.5 Colours on a Television Screen	547
25.4 Pigments and Paints	548
25.4.1 Colour of opaque objects	548
25.4.2 Colour of transparent objects	548
25.4.3 Pigment primary colours	549
25.5 End of Chapter Exercises	550
26 2D and 3D Wavefronts - Grade 12	553
26.1 Introduction	553
26.2 Wavefronts	553
26.3 The Huygens Principle	554
26.4 Interference	556
26.5 Diffraction	557
26.5.1 Diffraction through a Slit	558
26.6 Shock Waves and Sonic Booms	562
26.6.1 Subsonic Flight	563
26.6.2 Supersonic Flight	563
26.6.3 Mach Cone	566
26.7 End of Chapter Exercises	568
27 Wave Nature of Matter - Grade 12	571
27.1 Introduction	571
27.2 de Broglie Wavelength	571
27.3 The Electron Microscope	574
27.3.1 Disadvantages of an Electron Microscope	577

27.3.2	Uses of Electron Microscopes	577
27.4	End of Chapter Exercises	578
28	Electrodynamics - Grade 12	579
28.1	Introduction	579
28.2	Electrical machines - generators and motors	579
28.2.1	Electrical generators	580
28.2.2	Electric motors	582
28.2.3	Real-life applications	582
28.2.4	Exercise - generators and motors	584
28.3	Alternating Current	585
28.3.1	Exercise - alternating current	586
28.4	Capacitance and inductance	586
28.4.1	Capacitance	586
28.4.2	Inductance	586
28.4.3	Exercise - capacitance and inductance	588
28.5	Summary	588
28.6	End of chapter exercise	589
29	Electronics - Grade 12	591
29.1	Introduction	591
29.2	Capacitive and Inductive Circuits	591
29.3	Filters and Signal Tuning	596
29.3.1	Capacitors and Inductors as Filters	596
29.3.2	LRC Circuits, Resonance and Signal Tuning	596
29.4	Active Circuit Elements	599
29.4.1	The Diode	599
29.4.2	The Light Emitting Diode (LED)	601
29.4.3	Transistor	603
29.4.4	The Operational Amplifier	607
29.5	The Principles of Digital Electronics	609
29.5.1	Logic Gates	610
29.6	Using and Storing Binary Numbers	616
29.6.1	Binary numbers	616
29.6.2	Counting circuits	617
29.6.3	Storing binary numbers	619
30	EM Radiation	625
30.1	Introduction	625
30.2	Particle/wave nature of electromagnetic radiation	625
30.3	The wave nature of electromagnetic radiation	626
30.4	Electromagnetic spectrum	626
30.5	The particle nature of electromagnetic radiation	629

30.5.1 Exercise - particle nature of EM waves	630
30.6 Penetrating ability of electromagnetic radiation	631
30.6.1 Ultraviolet(UV) radiation and the skin	631
30.6.2 Ultraviolet radiation and the eyes	632
30.6.3 X-rays	632
30.6.4 Gamma-rays	632
30.6.5 Exercise - Penetrating ability of EM radiation	633
30.7 Summary	633
30.8 End of chapter exercise	633
31 Optical Phenomena and Properties of Matter - Grade 12	635
31.1 Introduction	635
31.2 The transmission and scattering of light	635
31.2.1 Energy levels of an electron	635
31.2.2 Interaction of light with metals	636
31.2.3 Why is the sky blue?	637
31.3 The photoelectric effect	638
31.3.1 Applications of the photoelectric effect	640
31.3.2 Real-life applications	642
31.4 Emission and absorption spectra	643
31.4.1 Emission Spectra	643
31.4.2 Absorption spectra	644
31.4.3 Colours and energies of electromagnetic radiation	646
31.4.4 Applications of emission and absorption spectra	648
31.5 Lasers	650
31.5.1 How a laser works	652
31.5.2 A simple laser	654
31.5.3 Laser applications and safety	655
31.6 Summary	656
31.7 End of chapter exercise	657
V Exercises	659
32 Exercises	661
VI Essays	663
Essay 1: Energy and electricity. Why the fuss?	665
33 Essay: How a cell phone works	671
34 Essay: How a Physiotherapist uses the Concept of Levers	673
35 Essay: How a Pilot Uses Vectors	675

A GNU Free Documentation License

677

Part II

Grade 10 - Physics

here we go ... again and again....

Chapter 2

Units

2.1 Introduction

Imagine you had to make curtains and needed to buy fabric. The shop assistant would need to know how much fabric you needed. Telling her you need fabric 2 wide and 6 long would be insufficient — you have to specify the **unit** (i.e. 2 *metres* wide and 6 *metres* long). Without the unit the information is incomplete and the shop assistant would have to guess. If you were making curtains for a doll's house the dimensions might be 2 centimetres wide and 6 centimetres long!

It is not just lengths that have units, all physical quantities have units (e.g. time, temperature, distance, etc.).



Definition: Physical Quantity

A physical quantity is anything that you can measure. For example, length, temperature, distance and time are physical quantities.

2.2 Unit Systems

2.2.1 SI Units

We will be using the SI units in this course. SI units are the internationally agreed upon units. Historically these units are based on the metric system which was developed in France at the time of the French Revolution.



Definition: SI Units

The name *SI units* comes from the French *Système International d'Unités*, which means *international system of units*.

There are seven base SI units. These are listed in Table 2.1. All physical quantities have units which can be built from these seven base units. These seven units were defined to be the base units. So, it is possible to create a different set of units by defining a different set of base units.

These seven units are called base units because none of them can be expressed as combinations of the other six. This is identical to bricks and concrete being the base units of a building. You can build different things using different combinations of bricks and concrete. The 26 letters of the alphabet are the base units for a language like English. Many different words can be formed by using these letters.

Base quantity	Name	Symbol
length	metre	m
mass	kilogram	kg
time	second	s
electric current	ampere	A
temperature	kelvin	K
amount of substance	mole	mol
luminous intensity	candela	cd

Table 2.1: SI Base Units

2.2.2 The Other Systems of Units

The SI Units are not the only units available, but they are most widely used. In Science there are three other sets of units that can also be used. These are mentioned here for interest only.

c.g.s Units

In the c.g.s. system, the metre is replaced by the centimetre and the kilogram is replaced by the gram. This is a simple change but it means that all units derived from these two are changed. For example, the units of force and work are different. These units are used most often in astrophysics and atomic physics.

Imperial Units

Imperial units arose when kings and queens decided the measures that were to be used in the land. All the imperial base units, except for the measure of time, are different to those of SI units. This is the unit system you are most likely to encounter if SI units are not used. Examples of imperial units are pounds, miles, gallons and yards. These units are used by the Americans and British. As you can imagine, having different units in use from place to place makes scientific communication very difficult. This was the motivation for adopting a set of internationally agreed upon units.

Natural Units

This is the most sophisticated choice of units. Here the most fundamental discovered quantities (such as the speed of light) are set equal to 1. The argument for this choice is that all other quantities should be built from these fundamental units. This system of units is used in high energy physics and quantum mechanics.

2.3 Writing Units as Words or Symbols

Unit names are always written with a lowercase first letter, for example, we write metre and litre. The symbols or abbreviations of units are also written with lowercase initials, for example m for metre and ℓ for litre. The exception to this rule is if the unit is named after a person, then the symbol is a capital letter. For example, the kelvin was named after Lord Kelvin and its symbol is K. If the abbreviation of the unit that is named after a person has two letters, the second letter is lowercase, for example Hz for hertz.



Exercise: Naming of Units

For the following symbols of units that you will come across later in this book, write whether you think the unit is named after a person or not.

-
- | | |
|---------------|----------------|
| 1. J (joule) | 5. C (coulomb) |
| 2. ℓ (litre) | 6. lm (lumen) |
| 3. N (newton) | 7. m (metre) |
| 4. mol (mole) | 8. bar (bar) |

2.4 Combinations of SI Base Units

To make working with units easier, some combinations of the base units are given special names, but it is always correct to reduce everything to the base units. Table 2.2 lists some examples of combinations of SI base units that are assigned special names. Do not be concerned if the formulae look unfamiliar at this stage - we will deal with each in detail in the chapters ahead (as well as many others)!

It is very important that you are able to recognise the units correctly. For instance, the **newton** (N) is another name for the **kilogram metre per second squared** ($\text{kg}\cdot\text{m}\cdot\text{s}^{-2}$), while the **kilogram metre squared per second squared** ($\text{kg}\cdot\text{m}^2\cdot\text{s}^{-2}$) is called the **joule** (J).

Quantity	Formula	Unit Expressed in Base Units	Name of Combination
Force	ma	$\text{kg}\cdot\text{m}\cdot\text{s}^{-2}$	N (newton)
Frequency	$\frac{1}{T}$	s^{-1}	Hz (hertz)
Work	$F\cdot s$	$\text{kg}\cdot\text{m}^2\cdot\text{s}^{-2}$	J (joule)

Table 2.2: Some examples of combinations of SI base units assigned special names



Important: When writing combinations of base SI units, place a dot (\cdot) between the units to indicate that different base units are used. For example, the symbol for metres per second is correctly written as $\text{m}\cdot\text{s}^{-1}$, and not as ms^{-1} or m/s .

2.5 Rounding, Scientific Notation and Significant Figures

2.5.1 Rounding Off

Certain numbers may take an infinite amount of paper and ink to write out. Not only is that impossible, but writing numbers out to a high accuracy (many decimal places) is very inconvenient and rarely gives better answers. For this reason we often estimate the number to a certain number of decimal places. Rounding off or approximating a decimal number to a given number of decimal places is the quickest way to approximate a number. For example, if you wanted to round-off 2,6525272 to three decimal places then you would first count three places after the decimal.

$$2,652|5272$$

All numbers to the right of $|$ are ignored after you determine whether the number in the third decimal place must be rounded up or rounded down. You *round up* the final digit (make the digit one more) if the first digit after the $|$ was greater or equal to 5 and *round down* (leave the digit alone) otherwise. So, since the first digit after the $|$ is a 5, we must round up the digit in the third decimal place to a 3 and the final answer of 2,6525272 rounded to three decimal places is 2,653.



Worked Example 1: Rounding-off

Question: Round-off $\pi = 3,141592654\dots$ to 4 decimal places.

Answer

Step 1 : Determine the last digit that is kept and mark the cut-off with $|$.

$$\pi = 3,1415|92654\dots$$

Step 2 : Determine whether the last digit is rounded up or down.

The last digit of $\pi = 3,1415|92654\dots$ must be rounded up because there is a 9 after the $|$.

Step 3 : Write the final answer.

$$\pi = 3,1416 \text{ rounded to 4 decimal places.}$$



Worked Example 2: Rounding-off

Question: Round-off 9,191919... to 2 decimal places

Answer

Step 1 : Determine the last digit that is kept and mark the cut-off with |.

9,19|1919...

Step 2 : Determine whether the last digit is rounded up or down.

The last digit of 9,19|1919... must be rounded down because there is a 1 after the |.

Step 3 : Write the final answer.

Answer = 9,19 rounded to 2 decimal places.

2.5.2 Error Margins

In a calculation that has many steps, it is best to leave the rounding off right until the end. For example, Jack and Jill walks to school. They walk 0,9 kilometers to get to school and it takes them 17 minutes. We can calculate their speed in the following two ways.

Method 1	Method 2
Change 17 minutes to hours: time = $\frac{17}{60}$ = 0,283333333 km	Change 17 minutes to hours: time = $\frac{17}{60}$ = 0,28 km
Speed = $\frac{Distance}{Time}$ = $\frac{0,9}{0,283333333}$ = 3,176470588	Speed = $\frac{Distance}{Time}$ = $\frac{0,9}{0,28}$ = 3,214285714
3,18 km·hr ⁻¹	3,21 km·hr ⁻¹

Table 2.3: Rounding numbers

You will see that we get two different answers. In Method 1 no rounding was done, but in Method 2, the time was rounded to 2 decimal places. This made a big difference to the answer. The answer in Method 1 is more accurate because rounded numbers were not used in the calculation. Always only round off your final answer.

2.5.3 Scientific Notation

In Science one often needs to work with very large or very small numbers. These can be written more easily in scientific notation, in the general form

$$d \times 10^e$$

where d is a decimal number between 0 and 10 that is rounded off to a few decimal places. e is known as the *exponent* and is an integer. If $e > 0$ it represents how many times the decimal place in d should be moved to the right. If $e < 0$, then it represents how many times the decimal place in d should be moved to the left. For example $3,24 \times 10^3$ represents 3240 (the decimal moved three places to the right) and $3,24 \times 10^{-3}$ represents 0,00324 (the decimal moved three places to the left).

If a number must be converted into scientific notation, we need to work out how many times the number must be multiplied or divided by 10 to make it into a number between 1 and 10 (i.e. the value of e) and what this number between 1 and 10 is (the value of d). We do this by counting the number of decimal places the decimal comma must move.

For example, write the speed of light in scientific notation, to two decimal places. The speed of light is 299 792 458 m·s⁻¹. First, find where the decimal comma must go for two decimal places (to find d) and then count how many places there are after the decimal comma to determine e .

In this example, the decimal comma must go after the first 2, but since the number after the 9 is 7, $d = 3,00$. $e = 8$ because there are 8 digits left after the decimal comma. So the speed of light in scientific notation, to two decimal places is $3,00 \times 10^8 \text{ m}\cdot\text{s}^{-1}$.

2.5.4 Significant Figures

In a number, each non-zero digit is a significant figure. Zeroes are only counted if they are between two non-zero digits or are at the end of the decimal part. For example, the number 2000 has 1 significant figure (the 2), but 2000,0 has 5 significant figures. You estimate a number like this by removing significant figures from the number (starting from the right) until you have the desired number of significant figures, rounding as you go. For example 6,827 has 4 significant figures, but if you wish to write it to 3 significant figures it would mean removing the 7 and rounding up, so it would be 6,83.



Exercise: Using Significant Figures

1. Round the following numbers:
 - (a) 123,517 ℓ to 2 decimal places
 - (b) 14,328 $\text{km}\cdot\text{h}^{-1}$ to one decimal place
 - (c) 0,00954 m to 3 decimal places
 2. Write the following quantities in scientific notation:
 - (a) 10130 Pa to 2 decimal places
 - (b) 978,15 $\text{m}\cdot\text{s}^{-2}$ to one decimal place
 - (c) 0,000001256 A to 3 decimal places
 3. Count how many significant figures each of the quantities below has:
 - (a) 2,590 km
 - (b) 12,305 $\text{m}\ell$
 - (c) 7800 kg
-

2.6 Prefixes of Base Units

Now that you know how to write numbers in scientific notation, another important aspect of units is the prefixes that are used with the units.



Definition: Prefix

A prefix is a group of letters that are placed in front of a word. The effect of the prefix is to change meaning of the word. For example, the prefix *un* is often added to a word to mean *not*, as in *unnecessary* which means *not necessary*.

In the case of units, the prefixes have a special use. The kilogram (kg) is a simple example. 1 kg is equal to 1 000 g or 1×10^3 g. Grouping the 10^3 and the g together we can replace the 10^3 with the prefix k (kilo). Therefore the k takes the place of the 10^3 . The kilogram is unique in that it is the only SI base unit containing a prefix.

In Science, all the prefixes used with units are some power of 10. Table 2.4 lists some of these prefixes. You will not use most of these prefixes, but those prefixes listed in **bold** should be learnt. The case of the prefix symbol is very important. Where a letter features twice in the table, it is written in uppercase for exponents bigger than one and in lowercase for exponents less than one. For example M means mega (10^6) and m means milli (10^{-3}).

Prefix	Symbol	Exponent	Prefix	Symbol	Exponent
yotta	Y	10^{24}	yocto	y	10^{-24}
zetta	Z	10^{21}	zepto	z	10^{-21}
exa	E	10^{18}	atto	a	10^{-18}
peta	P	10^{15}	femto	f	10^{-15}
tera	T	10^{12}	pico	p	10^{-12}
giga	G	10^9	nano	n	10^{-9}
mega	M	10^6	micro	μ	10^{-6}
kilo	k	10^3	milli	m	10^{-3}
hecto	h	10^2	centi	c	10^{-2}
deca	da	10^1	deci	d	10^{-1}

Table 2.4: Unit Prefixes



Important: There is no space and no dot between the prefix and the symbol for the unit.

Here are some examples of the use of prefixes:

- 40000 m can be written as 40 km (kilometre)
- 0,001 g is the same as 1×10^{-3} g and can be written as 1 mg (milligram)
- $2,5 \times 10^6$ N can be written as 2,5 MN (meganewton)
- 250000 A can be written as 250 kA (kiloampere) or 0,250 MA (megaampere)
- 0,000000075 s can be written as 75 ns (nanoseconds)
- 3×10^{-7} mol can be rewritten as $0,3 \times 10^{-6}$ mol, which is the same as 0,3 μ mol (micromol)



Exercise: Using Scientific Notation

- Write the following in scientific notation using Table 2.4 as a reference.
 - 0,511 MV
 - 10 cℓ
 - 0,5 μ m
 - 250 nm
 - 0,00035 hg
- Write the following using the prefixes in Table 2.4.
 - $1,602 \times 10^{-19}$ C
 - $1,992 \times 10^6$ J
 - $5,98 \times 10^4$ N
 - 25×10^{-4} A
 - $0,0075 \times 10^6$ m

2.7 The Importance of Units

Without units much of our work as scientists would be meaningless. We need to express our thoughts clearly and units give meaning to the numbers we measure and calculate. Depending on which units we use, the numbers are different. For example if you have 12 water, it means nothing. You could have 12 ml of water, 12 litres of water, or even 12 bottles of water. Units are an essential part of the language we use. Units must be specified when expressing physical quantities. Imagine that you are baking a cake, but the units, like grams and millilitres, for the flour, milk, sugar and baking powder are not specified!

Activity :: Investigation : Importance of Units

Work in groups of 5 to discuss other possible situations where using the incorrect set of units can be to your disadvantage or even dangerous. Look for examples at home, at school, at a hospital, when travelling and in a shop.

Activity :: Case Study : The importance of units

Read the following extract from CNN News 30 September 1999 and answer the questions below.

NASA: Human error caused loss of Mars orbiter November 10, 1999

Failure to convert English measures to metric values caused the loss of the Mars Climate Orbiter, a spacecraft that smashed into the planet instead of reaching a safe orbit, a NASA investigation concluded Wednesday.

The Mars Climate Orbiter, a key craft in the space agency's exploration of the red planet, vanished on 23 September after a 10 month journey. It is believed that the craft came dangerously close to the atmosphere of Mars, where it presumably burned and broke into pieces.

An investigation board concluded that NASA engineers failed to convert English measures of rocket thrusts to newton, a metric system measuring rocket force. One English pound of force equals 4,45 newtons. A small difference between the two values caused the spacecraft to approach Mars at too low an altitude and the craft is thought to have smashed into the planet's atmosphere and was destroyed.

The spacecraft was to be a key part of the exploration of the planet. From its station about the red planet, the Mars Climate Orbiter was to relay signals from the Mars Polar Lander, which is scheduled to touch down on Mars next month.

"The root cause of the loss of the spacecraft was a failed translation of English units into metric units and a segment of ground-based, navigation-related mission software," said Arthus Stephenson, chairman of the investigation board.

Questions:

1. Why did the Mars Climate Orbiter crash? Answer in your own words.
 2. How could this have been avoided?
 3. Why was the Mars Orbiter sent to Mars?
 4. Do you think space exploration is important? Explain your answer.
-

2.8 How to Change Units

It is very important that you are aware that different systems of units exist. Furthermore, you must be able to convert between units. Being able to change between units (for example, converting from millimetres to metres) is a useful skill in Science.

The following conversion diagrams will help you change from one unit to another.

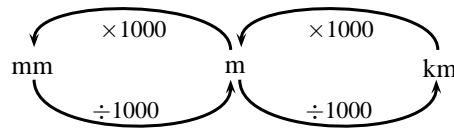

Figure 2.1: The distance conversion table

If you want to change millimetre to metre, you divide by 1000 (follow the arrow from mm to m); or if you want to change kilometre to millimetre, you multiply by 1000×1000 .

The same method can be used to change millilitre to litre or kilolitre. Use figure 2.2 to change volumes:

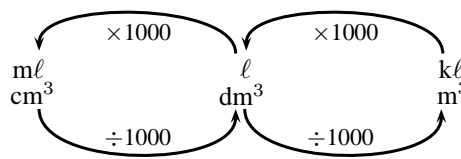

Figure 2.2: The volume conversion table



Worked Example 3: Conversion 1

Question: Express 3 800 mm in metres.

Answer

Step 1 : Find the two units on the conversion diagram.

Use Figure 2.1 . Millimetre is on the left and metre in the middle.

Step 2 : Decide whether you are moving to the left or to the right.

You need to go from mm to m, so you are moving from left to right.

Step 3 : Read from the diagram what you must do and find the answer.

$$3\,800 \text{ mm} \div 1000 = 3,8 \text{ m}$$



Worked Example 4: Conversion 2

Question: Convert 4,56 kg to g.

Answer

Step 1 : Find the two units on the conversion diagram.

Use Figure 2.1. Kilogram is the same as kilometre and gram the same as metre.

Step 2 : Decide whether you are moving to the left or to the right.

You need to go from kg to g, so it is from right to left.

Step 3 : Read from the diagram what you must do and find the answer.

$$4,56 \text{ kg} \times 1000 = 4560 \text{ g}$$

2.8.1 Two other useful conversions

Very often in Science you need to convert speed and temperature. The following two rules will help you do this:

Converting speed

When converting $\text{km}\cdot\text{h}^{-1}$ to $\text{m}\cdot\text{s}^{-1}$ you divide by 3,6. For example $72 \text{ km}\cdot\text{h}^{-1} \div 3,6 = 20 \text{ m}\cdot\text{s}^{-1}$.

When converting $\text{m}\cdot\text{s}^{-1}$ to $\text{km}\cdot\text{h}^{-1}$, you multiply by 3,6. For example $30 \text{ m}\cdot\text{s}^{-1} \times 3,6 = 108 \text{ km}\cdot\text{h}^{-1}$.

Converting temperature

Converting between the kelvin and celsius temperature scales is easy. To convert from celsius to kelvin add 273. To convert from kelvin to celsius subtract 273. Representing the kelvin temperature by T_K and the celsius temperature by $T_{\circ C}$,

$$T_K = T_{\circ C} + 273$$

2.9 A sanity test

A sanity test is a method of checking whether an answer makes sense. All we have to do is to take a careful look at our answer and ask the question *Does the answer make sense?*

Imagine you were calculating the number of people in a classroom. If the answer you got was 1 000 000 people you would know it was wrong — it is not possible to have that many people in a classroom. That is all a sanity test is — is your answer insane or not?

It is useful to have an idea of some numbers before we start. For example, let us consider masses. An average person has a mass around 70 kg, while the heaviest person in medical history had a mass of 635 kg. If you ever have to calculate a person's mass and you get 7 000 kg, this should fail your sanity check — your answer is insane and you must have made a mistake somewhere. In the same way an answer of 0.01 kg should fail your sanity test.

The only problem with a sanity check is that you must know what typical values for things are. For example, finding the number of learners in a classroom you need to know that there are usually 20–50 people in a classroom. If you get an answer of 2500, you should realise that it is wrong.

Activity :: The scale of the matter... : Try to get an idea of the typical values for the following physical quantities and write your answers into the table:

Category	Quantity	Minimum	Maximum
People	mass		
	height		
Transport	speed of cars on freeways		
	speed of trains		
	speed of aeroplanes		
	distance between home and school		
General	thickness of a sheet of paper		
	height of a doorway		

2.10 Summary

1. You need to know the seven base SI Units as listed in table 2.1. Combinations of SI Units can have different names.

2.11 End of Chapter Exercises

1. Write down the SI unit for each of the following quantities:
 - (a) length
 - (b) time
 - (c) mass
 - (d) quantity of matter(4)

2. For each of the following units, write down the symbol and what power of 10 it represents:
 - (a) millimetre
 - (b) centimetre
 - (c) metre
 - (d) kilometre(4)

3. For each of the following symbols, write out the unit in full and write what power of 10 it represents:
 - (a) μg
 - (b) mg
 - (c) kg
 - (d) Mg(4)

4. Write each of the following in scientific notation, correct to 2 decimal places:
 - (a) 0,00000123 N
 - (b) 417 000 000 kg
 - (c) 246800 A
 - (d) 0,00088 mm(4)

5. Rewrite each of the following, using the correct prefix using 2 decimal places where applicable:
 - (a) 0,00000123 N
 - (b) 417 000 000 kg
 - (c) 246800 A
 - (d) 0,00088 mm(4)

6. For each of the following, write the measurement using the correct symbol for the prefix and the base unit:
 - (a) 1,01 microseconds
 - (b) 1 000 milligrams
 - (c) 7,2 megameters
 - (d) 11 nanolitre(4)

7. The Concorde is a type of aeroplane that flies very fast. The top speed of the Concorde is $844 \text{ km}\cdot\text{hr}^{-1}$. Convert the Concorde's top speed to $\text{m}\cdot\text{s}^{-1}$. (3)

8. The boiling point of water is $100 \text{ }^\circ\text{C}$. What is the boiling point of water in kelvin? (3)

Total = 30

Chapter 3

Motion in One Dimension - Grade 10

3.1 Introduction

This chapter is about how things move in a straight line or more scientifically how things move *in one dimension*. This is useful for learning how to describe the movement of cars along a straight road or of trains along straight railway tracks. If you want to understand how any object moves, for example a car on the freeway, a soccer ball being kicked towards the goal or your dog chasing the neighbour's cat, then you have to understand three basic ideas about what it means when something *is moving*. These three ideas describe different parts of exactly how an object moves. They are:

1. position or displacement which tells us exactly where the object is,
2. speed or velocity which tells us exactly how fast the object's position is changing or more familiarly, how fast the object is moving, and
3. acceleration which tells us exactly how fast the object's velocity is changing.

You will also learn how to use position, displacement, speed, velocity and acceleration to describe the motion of simple objects. You will learn how to read and draw graphs that summarise the motion of a moving object. You will also learn about the equations that can be used to describe motion and how to apply these equations to objects moving in one dimension.

3.2 Reference Point, Frame of Reference and Position

The most important idea when studying motion, is you have to know where you are. The word *position* describes your location (where you are). However, saying that you are *here* is meaningless, and you have to specify your position *relative* to a known reference point. For example, if you are 2 m from the doorway, inside your classroom then your reference point is the doorway. This defines your position inside the classroom. Notice that you need a reference point (the doorway) and a direction (inside) to define your location.

3.2.1 Frames of Reference

**Definition: Frame of Reference**

A frame of reference is a reference point combined with a set of directions.

A *frame of reference* is similar to the idea of a reference point. A frame of reference is defined as a reference point combined with a set of directions. For example, a boy is standing still inside

a train as it pulls out of a station. You are standing on the platform watching the train move from left to right. To you it looks as if the boy is moving from left to right, because relative to where you are standing (the platform), he is moving. According to the boy, and his *frame of reference* (the train), he is not moving.

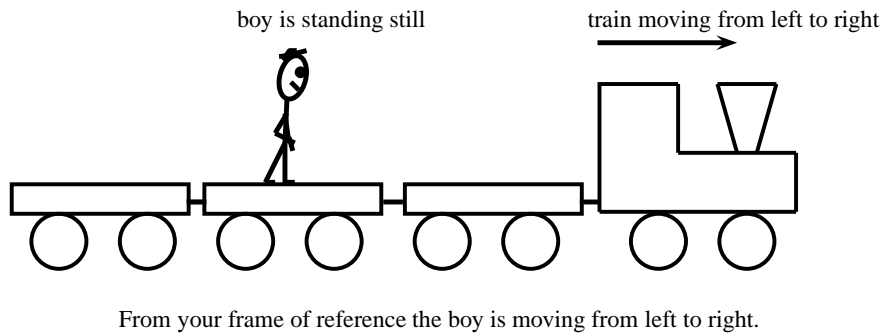
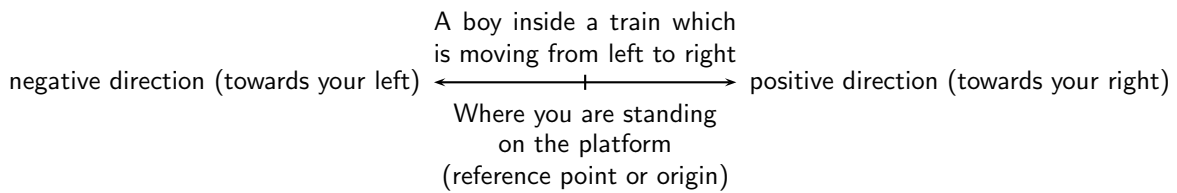

Figure 3.1: Frames of Reference

A frame of reference must have an origin (where you are standing on the platform) and at least a positive direction. The train was moving from left to right, making to your right positive and to your left negative. If someone else was looking at the same boy, his frame of reference will be different. For example, if he was standing on the other side of the platform, the boy will be moving from right to left.

For this chapter, we will only use frames of reference in the x -direction. Frames of reference will be covered in more detail in Grade 12.



3.2.2 Position



Definition: Position

Position is a measurement of a location, with reference to an origin.

A position is a measurement of a location, with reference to an origin. Positions can therefore be negative or positive. The symbol x is used to indicate position. x has units of length for example cm, m or km. Figure 3.2.2 shows the position of a school. Depending on what reference point we choose, we can say that the school is 300 m from Joan's house (with Joan's house as the reference point or origin) or 500 m from Joel's house (with Joel's house as the reference point or origin).

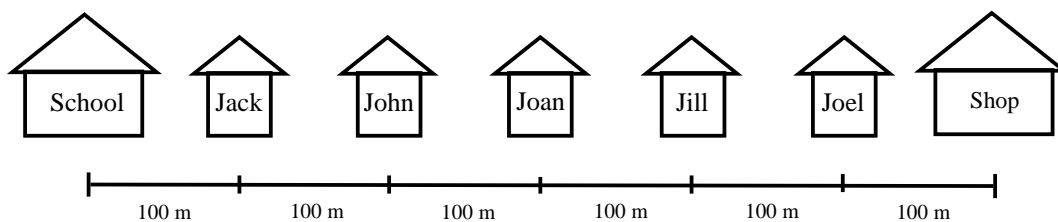

Figure 3.2: Illustration of position

The shop is also 300 m from Joan's house, but in the opposite direction as the school. When we choose a reference point, we have a positive direction and a negative direction. If we choose

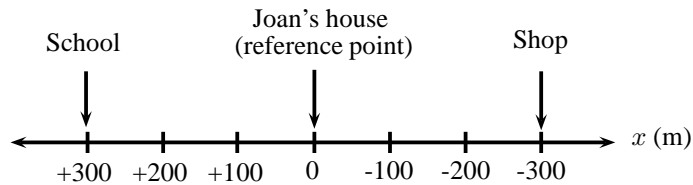

Figure 3.3: The origin is at Joan's house and the position of the school is +300 m. Positions towards the left are defined as positive and positions towards the right are defined as negative.

the direction towards the school as positive, then the direction towards the shop is negative. A negative direction is always opposite to the direction chosen as positive.

Activity :: Discussion : Reference Points

Divide into groups of 5 for this activity. On a straight line, choose a reference point. Since position can have both positive and negative values, discuss the advantages and disadvantages of choosing

1. either end of the line,
2. the middle of the line.

This reference point can also be called "the origin".



Exercise: Position

1. Write down the positions for objects at A, B, D and E. Do not forget the units.

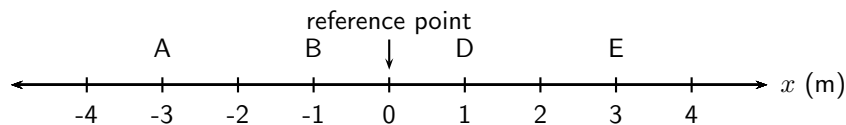

2. Write down the positions for objects at F, G, H and J. Do not forget the units.

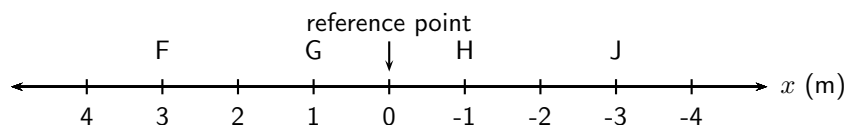

3. There are 5 houses on Newton Street, A, B, C, D and E. For all cases, assume that positions to the right are positive.

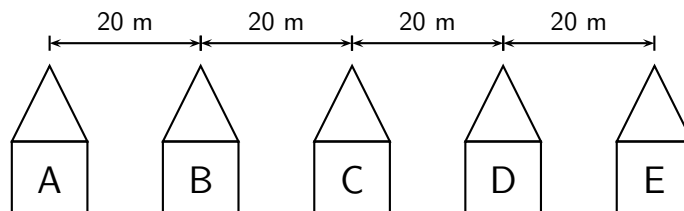

- (a) Draw a frame of reference with house A as the origin and write down the positions of houses B, C, D and E.
- (b) You live in house C. What is your position relative to house E?
- (c) What are the positions of houses A, B and D, if house B is taken as the reference point?
-

3.3 Displacement and Distance



Definition: Displacement

Displacement is the change in an object's position.

The displacement of an object is defined as its change in position (final position minus initial position). Displacement has a magnitude and direction and is therefore a vector. For example, if the initial position of a car is x_i and it moves to a final position of x_f , then the displacement is:

$$x_f - x_i$$

However, subtracting an initial quantity from a final quantity happens often in Physics, so we use the shortcut Δ to mean *final - initial*. Therefore, displacement can be written:

$$\Delta x = x_f - x_i$$



Important: The symbol Δ is read out as *delta*. Δ is a letter of the Greek alphabet and is used in Mathematics and Science to indicate a change in a certain quantity, or a final value minus an initial value. For example, Δx means change in x while Δt means change in t .



Important: The words *initial* and *final* will be used very often in Physics. *Initial* will always refer to something that happened earlier in time and *final* will always refer to something that happened later in time. It will often happen that the final value is smaller than the initial value, such that the difference is negative. This is ok!

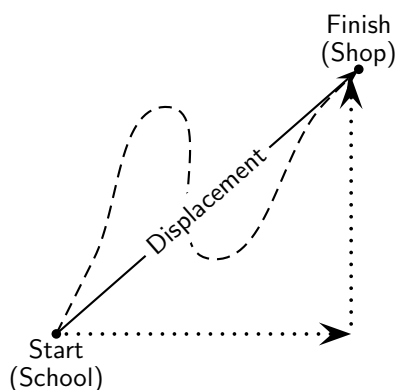

Figure 3.4: Illustration of displacement

Displacement does not depend on the path travelled, but only on the initial and final positions (Figure 3.4). We use the word *distance* to describe how far an object travels along a particular path. Distance is the actual distance that was covered. Distance (symbol d) does not have a direction, so it is a scalar. Displacement is the shortest distance from the starting point to the endpoint – from the school to the shop in the figure. Displacement has direction and is therefore a vector.

Figure 3.2.2 shows the five houses we discussed earlier. Jack walks to school, but instead of walking straight to school, he decided to walk to his friend Joel's house first to fetch him so that they can walk to school together. Jack covers a distance of 400 m to Joel's house and another 500 m to school. He covers a distance of 900 m. His displacement, however, is only 100 m towards the school. This is because displacement only looks at the starting position (his house) and the end position (the school). It does not depend on the path he travelled.

To calculate his distance and displacement, we need to choose a reference point and a direction. Let's choose Jack's house as the reference point, and towards Joel's house as the positive direction (which means that towards the school is negative). We would do the calculations as follows:

$$\begin{array}{ll}
 \text{Distance}(d) & = \text{path travelled} & \text{Displacement}(\Delta x) & = x_f - x_i \\
 & = 400 \text{ m} + 500 \text{ m} & & = -100 \text{ m} + 0 \text{ m} \\
 & = 900 \text{ m} & & = -100 \text{ m}
 \end{array}$$

Joel walks to school with Jack and after school walks back home. What is Joel's displacement and what distance did he cover? For this calculation we use Joel's house as the reference point. Let's take towards the school as the positive direction.

$$\begin{array}{ll}
 \text{Distance}(d) & = \text{path travelled} & \text{Displacement}(\Delta x) & = x_f - x_i \\
 & = 500 \text{ m} + 500 \text{ m} & & = 0 \text{ m} + 0 \text{ m} \\
 & = 1000 \text{ m} & & = 0 \text{ m}
 \end{array}$$

It is possible to have a displacement of 0 m and a distance that is not 0 m. This happens when an object completes a round trip back to its original position, like an athlete running around a track.

3.3.1 Interpreting Direction

Very often in calculations you will get a negative answer. For example, Jack's displacement in the example above, is calculated as -100 m. The minus sign in front of the answer means that his displacement is 100 m in the opposite direction (opposite to the direction chosen as positive in the beginning of the question). When we start a calculation we choose a frame of reference and a positive direction. In the first example above, the reference point is Jack's house and the positive direction is towards Joel's house. Therefore Jack's displacement is 100 m towards the school. Notice that distance has no direction, but displacement has.

3.3.2 Differences between Distance and Displacement



Definition: Vectors and Scalars

A vector is a physical quantity with magnitude (size) and direction. A scalar is a physical quantity with magnitude (size) only.

The differences between distance and displacement can be summarised as:

Distance	Displacement
1. depends on the path	1. independent of path taken
2. always positive	2. can be positive or negative
3. is a scalar	3. is a vector



Exercise: Point of Reference

- Use Figure 3.2.2 to answer the following questions.
 - Jill walks to Joan's house and then to school, what is her distance and displacement?
 - John walks to Joan's house and then to school, what is his distance and displacement?

- (c) Jack walks to the shop and then to school, what is his distance and displacement?
- (d) What reference point did you use for each of the above questions?
2. You stand at the front door of your house (displacement, $\Delta x = 0$ m). The street is 10 m away from the front door. You walk to the street and back again.
- (a) What is the distance you have walked?
- (b) What is your final displacement?
- (c) Is displacement a vector or a scalar? Give a reason for your answer.
-

3.4 Speed, Average Velocity and Instantaneous Velocity

Definition: Velocity

Velocity is the rate of change of position.

Definition: Instantaneous velocity

Instantaneous velocity is the velocity of an accelerating body at a specific instant in time.

Definition: Average velocity

Average velocity is the total displacement of a body over a time interval.

Velocity is the rate of change of position. It tells us how much an object's position changes in time. This is the same as the displacement divided by the time taken. Since displacement is a vector and time taken is a scalar, velocity is also a vector. We use the symbol v for velocity. If we have a displacement of Δx and a time taken of Δt , v is then defined as:

$$\begin{aligned} \text{velocity (in m} \cdot \text{s}^{-1}\text{)} &= \frac{\text{change in displacement (in m)}}{\text{change in time (in s)}} \\ v &= \frac{\Delta x}{\Delta t} \end{aligned}$$

Velocity can be positive or negative. Positive values of velocity mean that the object is moving away from the reference point or origin and negative values mean that the object is moving towards the reference point or origin.



Important: An instant in time is different from the time taken or the time interval. It is therefore useful to use the symbol t for an instant in time (for example during the 4th second) and the symbol Δt for the time taken (for example during the first 5 seconds of the motion).

Average velocity (symbol v) is the displacement for the whole motion divided by the time taken for the whole motion. Instantaneous velocity is the velocity at a specific instant in time.

(Average) Speed (symbol s) is the distance travelled (d) divided by the time taken (Δt) for the journey. Distance and time are scalars and therefore speed will also be a scalar. Speed is calculated as follows:

$$\begin{aligned} \text{speed (in m} \cdot \text{s}^{-1}\text{)} &= \frac{\text{distance (in m)}}{\text{time (in s)}} \\ s &= \frac{d}{\Delta t} \end{aligned}$$

Instantaneous speed is the magnitude of instantaneous velocity. It has the same value, but no direction.

Worked Example 5: Average speed and average velocity

Question: James walks 2 km away from home in 30 minutes. He then turns around and walks back home along the same path, also in 30 minutes. Calculate James' average speed and average velocity.

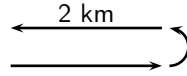

Answer

Step 1 : Identify what information is given and what is asked for

The question explicitly gives

- the distance and time out (2 km in 30 minutes)
- the distance and time back (2 km in 30 minutes)

Step 2 : Check that all units are SI units.

The information is not in SI units and must therefore be converted.

To convert km to m, we know that:

$$1 \text{ km} = 1\,000 \text{ m}$$

$$\therefore 2 \text{ km} = 2\,000 \text{ m} \quad (\text{multiply both sides by 2, because we want to convert 2 km to m.})$$

Similarly, to convert 30 minutes to seconds,

$$1 \text{ min} = 60 \text{ s}$$

$$\therefore 30 \text{ min} = 1\,800 \text{ s} \quad (\text{multiply both sides by 30})$$

Step 3 : Determine James' displacement and distance.

James started at home and returned home, so his displacement is 0 m.

$$\Delta x = 0 \text{ m}$$

James walked a total distance of 4 000 m (2 000 m out and 2 000 m back).

$$d = 4\,000 \text{ m}$$

Step 4 : Determine his total time.

James took 1 800 s to walk out and 1 800 s to walk back.

$$\Delta t = 3\,600 \text{ s}$$

Step 5 : Determine his average speed

$$\begin{aligned} s &= \frac{d}{\Delta t} \\ &= \frac{4\,000 \text{ m}}{3\,600 \text{ s}} \\ &= 1,11 \text{ m} \cdot \text{s}^{-1} \end{aligned}$$

Step 6 : Determine his average velocity

$$\begin{aligned} v &= \frac{\Delta x}{\Delta t} \\ &= \frac{0 \text{ m}}{3\,600 \text{ s}} \\ &= 0 \text{ m} \cdot \text{s}^{-1} \end{aligned}$$



Question: A man runs around a circular track of radius 100 m. It takes him 120 s to complete a revolution of the track. If he runs at constant speed, calculate:

1. his speed,
2. his instantaneous velocity at point A,
3. his instantaneous velocity at point B,
4. his average velocity between points A and B,
5. his average speed during a revolution.
6. his average velocity during a revolution.

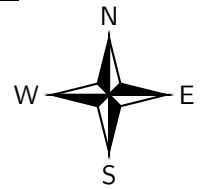
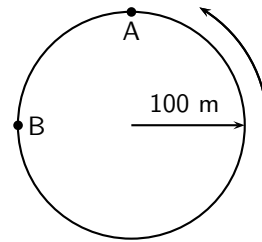

Direction the man runs

Answer

Step 1 : Decide how to approach the problem

To determine the man's speed we need to know the distance he travels and how long it takes. We know it takes 120 s to complete one revolution of the track. (A revolution is to go around the track once.)

Step 2 : Determine the distance travelled

What distance is one revolution of the track? We know the track is a circle and we know its radius, so we can determine the distance around the circle. We start with the equation for the circumference of a circle

$$\begin{aligned} C &= 2\pi r \\ &= 2\pi(100 \text{ m}) \\ &= 628,32 \text{ m} \end{aligned}$$

Therefore, the distance the man covers in one revolution is 628,32 m.

Step 3 : Determine the speed

We know that speed is distance covered per unit time. So if we divide the distance covered by the time it took we will know how much distance was covered for every unit of time. No direction is used here because speed is a scalar.

$$\begin{aligned} s &= \frac{d}{\Delta t} \\ &= \frac{628,32 \text{ m}}{120 \text{ s}} \\ &= 5,24 \text{ m} \cdot \text{s}^{-1} \end{aligned}$$

Step 4 : Determine the instantaneous velocity at A

Consider the point A in the diagram. We know which way the man is running around the track and we know his speed. His velocity at point A will be his speed (the magnitude of the velocity) plus his direction of motion (the direction of his velocity). The instant that he arrives at A he is moving as indicated in the diagram.

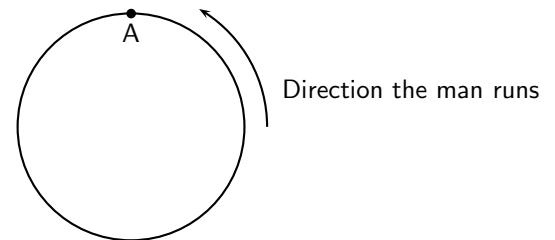

His velocity will be $5,24 \text{ m} \cdot \text{s}^{-1}$ West.

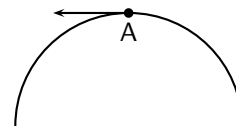
**Step 5 : Determine the instantaneous velocity at B**

Consider the point B in the diagram. We know which way the man is running around the track and we know his speed. His velocity at point B will be his speed (the magnitude of the velocity) plus his direction of motion (the direction of his velocity). The instant that he arrives at B he is moving as indicated in the diagram.

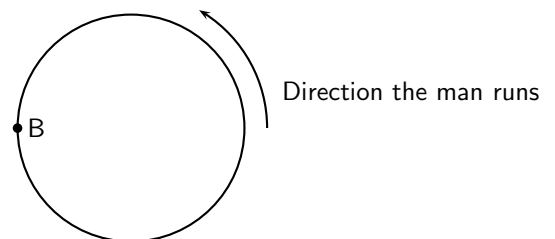

His velocity will be $5,24 \text{ m} \cdot \text{s}^{-1}$ South.

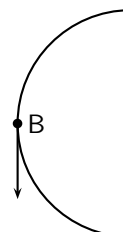

Step 6 : Determine the average velocity between A and B

To determine the average velocity between A and B, we need the change in displacement between A and B and the change in time between A and B. The displacement from A and B can be calculated by using the Theorem of Pythagoras:

$$\begin{aligned}(\Delta x)^2 &= 100^2 + 100^2 \\ &= 20000 \\ \Delta x &= 141,42135\dots \text{ m}\end{aligned}$$

The time for a full revolution is 120 s, therefore the time for a $\frac{1}{4}$ of a revolution is 30 s.

$$\begin{aligned}v_{AB} &= \frac{\Delta x}{\Delta t} \\ &= \frac{141,42\dots}{30 \text{ s}} \\ &= 4.71 \text{ m} \cdot \text{s}^{-1}\end{aligned}$$

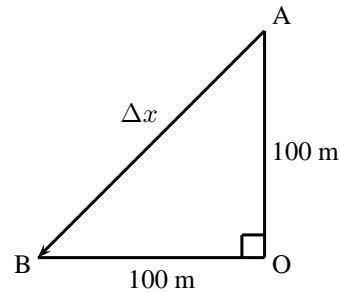

Velocity is a vector and needs a direction.

Triangle AOB is isosceles and therefore angle BAO = 45°.

The direction is between west and south and is therefore southwest.

The final answer is: $v = 4.71 \text{ m} \cdot \text{s}^{-1}$, southwest.

Step 7 : Determine his average speed during a revolution

Because he runs at a constant rate, we know that his speed anywhere around the track will be the same. His average speed is $5,24 \text{ m} \cdot \text{s}^{-1}$.

Step 8 : Determine his average velocity over a complete revolution

Important: Remember - displacement can be zero even when distance travelled is not!

To calculate average velocity we need his total displacement and his total time. His displacement is zero because he ends up where he started. His time is 120 s. Using these we can calculate his average velocity:

$$\begin{aligned}v &= \frac{\Delta x}{\Delta t} \\ &= \frac{0 \text{ m}}{120 \text{ s}} \\ &= 0 \text{ s}\end{aligned}$$

3.4.1 Differences between Speed and Velocity

The differences between speed and velocity can be summarised as:

Speed	Velocity
1. depends on the path taken	1. independent of path taken
2. always positive	2. can be positive or negative
3. is a scalar	3. is a vector
4. no dependence on direction and so is only positive	4. direction can be guessed from the sign (i.e. positive or negative)

Additionally, an object that makes a round trip, i.e. travels away from its starting point and then returns to the same point has zero velocity but travels a non-zero speed.



Exercise: Displacement and related quantities

- Theresa has to walk to the shop to buy some milk. After walking 100 m, she realises that she does not have enough money, and goes back home. If it took her two minutes to leave and come back, calculate the following:
 - How long was she out of the house (the time interval Δt in seconds)?
 - How far did she walk (distance (d))?
 - What was her displacement (Δx)?
 - What was her average velocity (in $\text{m}\cdot\text{s}^{-1}$)?
 - What was her average speed (in $\text{m}\cdot\text{s}^{-1}$)?

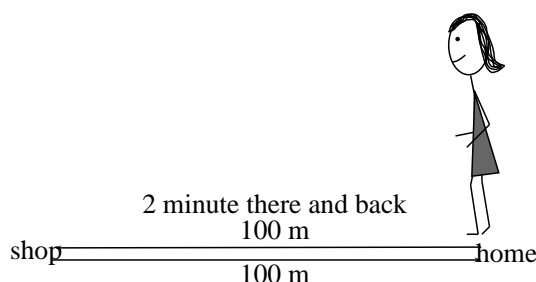

- Desmond is watching a straight stretch of road from his classroom window. He can see two poles which he earlier measured to be 50 m apart. Using his stopwatch, Desmond notices that it takes 3 s for most cars to travel from the one pole to the other.
 - Using the equation for velocity ($v = \frac{\Delta x}{\Delta t}$), show all the working needed to calculate the velocity of a car travelling from the left to the right.
 - If Desmond measures the velocity of a red Golf to be $-16,67 \text{ m}\cdot\text{s}^{-1}$, in which direction was the Gold travelling?
Desmond leaves his stopwatch running, and notices that at $t = 5,0 \text{ s}$, a taxi passes the left pole at the same time as a bus passes the right pole. At time $t = 7,5 \text{ s}$ the taxi passes the right pole. At time $t = 9,0 \text{ s}$, the bus passes the left pole.
 - How long did it take the taxi and the bus to travel the distance between the poles? (Calculate the time interval (Δt) for both the taxi and the bus).
 - What was the velocity of the taxi and the bus?
 - What was the speed of the taxi and the bus?
 - What was the speed of taxi and the bus in $\text{km}\cdot\text{h}^{-1}$?

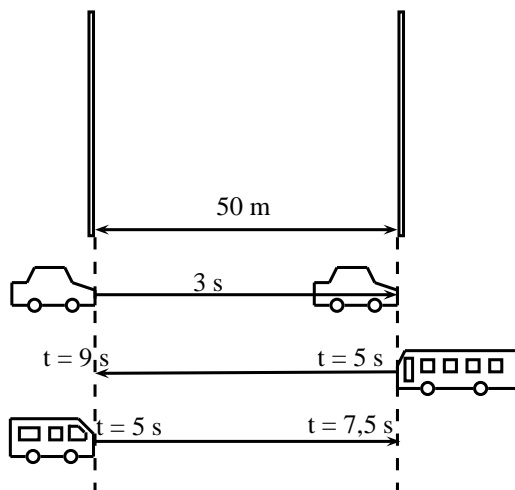

- After a long day, a tired man decides not to use the pedestrian bridge to cross over a freeway, and decides instead to run across. He sees a car 100 m away travelling towards him, and is confident that he can cross in time.

- If the car is travelling at $120 \text{ km}\cdot\text{h}^{-1}$, what is the car's speed in $\text{m}\cdot\text{s}^{-1}$.
- How long will it take the a car to travel 100 m?
- If the man is running at $10 \text{ km}\cdot\text{h}^{-1}$, what is his speed in $\text{m}\cdot\text{s}^{-1}$?
- If the freeway has 3 lanes, and each lane is 3 m wide, how long will it take for the man to cross all three lanes?
- If the car is travelling in the furthestmost lane from the man, will he be able to cross all 3 lanes of the freeway safely?

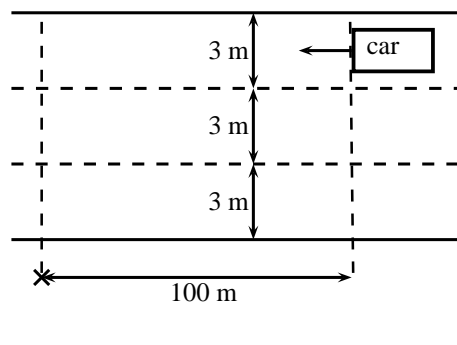

Activity :: Investigation : An Exercise in Safety

Divide into groups of 4 and perform the following investigation. Each group will be performing the same investigation, but the aim for each group will be different.

- Choose an aim for your investigation from the following list and formulate a hypothesis:
 - Do cars travel at the correct speed limit?
 - Is it safe to cross the road outside of a pedestrian crossing?
 - Does the colour of your car determine the speed you are travelling at?
 - Any other relevant question that you would like to investigate.
- On a road that you often cross, measure out 50 m along a straight section, far away from traffic lights or intersections.
- Use a stopwatch to record the time each of 20 cars take to travel the 50 m section you measured.
- Design a table to represent your results. Use the results to answer the question posed in the aim of the investigation. You might need to do some more measurements for your investigation. Plan in your group what else needs to be done.
- Complete any additional measurements and write up your investigation under the following headings:
 - Aim and Hypothesis
 - Apparatus
 - Method
 - Results
 - Discussion
 - Conclusion
- Answer the following questions:
 - How many cars took less than 3 seconds to travel 50 m?
 - What was the shortest time a car took to travel 50 m?
 - What was the average time taken by the 20 cars?
 - What was the average speed of the 20 cars?
 - Convert the average speed to $\text{km}\cdot\text{h}^{-1}$.

3.5 Acceleration



Definition: Acceleration

Acceleration is the rate of change of velocity.

Acceleration (symbol a) is the rate of change of velocity. It is a measure of how fast the velocity of an object changes in time. If we have a change in velocity (Δv) over a time interval (Δt), then the acceleration (a) is defined as:

$$\text{acceleration (in m} \cdot \text{s}^{-2}\text{)} = \frac{\text{change in velocity (in m} \cdot \text{s}^{-1}\text{)}}{\text{change in time (in s)}}$$

$$a = \frac{\Delta v}{\Delta t}$$

Since velocity is a vector, acceleration is also a vector. Acceleration does not provide any information about a motion, but only about how the motion changes. It is not possible to tell how fast an object is moving or in which direction from the acceleration.

Like velocity, acceleration can be negative or positive. We see that when the sign of the acceleration and the velocity are the same, the object is speeding up. If both velocity and acceleration are positive, the object is speeding up in a positive direction. If both velocity and acceleration are negative, the object is speeding up in a negative direction. If velocity is positive and acceleration is negative, then the object is slowing down. Similarly, if the velocity is negative and the acceleration is positive the object is slowing down. This is illustrated in the following worked example.



Worked Example 7: Acceleration

Question: A car accelerates uniformly from an initial velocity of $2 \text{ m} \cdot \text{s}^{-1}$ to a final velocity of $10 \text{ m} \cdot \text{s}^{-1}$ in 8 seconds. It then slows down uniformly to a final velocity of $4 \text{ m} \cdot \text{s}^{-1}$ in 6 seconds. Calculate the acceleration of the car during the first 8 seconds and during the last 6 seconds.

Answer

Step 9 : Identify what information is given and what is asked for:

Consider the motion of the car in two parts: the first 8 seconds and the last 6 seconds.

For the first 8 seconds:

$$\begin{aligned} v_i &= 2 \text{ m} \cdot \text{s}^{-1} \\ v_f &= 10 \text{ m} \cdot \text{s}^{-1} \\ t_i &= 0 \text{ s} \\ t_f &= 8 \text{ s} \end{aligned}$$

For the last 6 seconds:

$$\begin{aligned} v_i &= 10 \text{ m} \cdot \text{s}^{-1} \\ v_f &= 4 \text{ m} \cdot \text{s}^{-1} \\ t_i &= 8 \text{ s} \\ t_f &= 14 \text{ s} \end{aligned}$$

Step 10 : Calculate the acceleration.

For the first 8 seconds:

$$\begin{aligned} a &= \frac{\Delta v}{\Delta t} \\ &= \frac{10 - 2}{8 - 0} \\ &= 1 \text{ m} \cdot \text{s}^{-2} \end{aligned}$$

For the next 6 seconds:

$$\begin{aligned} a &= \frac{\Delta v}{\Delta t} \\ &= \frac{4 - 10}{14 - 8} \\ &= -1 \text{ m} \cdot \text{s}^{-2} \end{aligned}$$

During the first 8 seconds the car had a positive acceleration. This means that its velocity increased. The velocity is positive so the car is speeding up. During the next 6 seconds the car had a negative acceleration. This means that its velocity decreased. The velocity is positive so the car is slowing down.



Important: Acceleration does not tell us about the direction of the motion. Acceleration only tells us how the velocity changes.



Important: Deceleration

Avoid the use of the word *deceleration* to refer to a negative acceleration. This word usually means *slowing down* and it is possible for an object to slow down with both a positive and negative acceleration, because the sign of the velocity of the object must also be taken into account to determine whether the body is slowing down or not.



Exercise: Acceleration

1. An athlete is accelerating uniformly from an initial velocity of $0 \text{ m}\cdot\text{s}^{-1}$ to a final velocity of $4 \text{ m}\cdot\text{s}^{-1}$ in 2 seconds. Calculate his acceleration. Let the direction that the athlete is running in be the positive direction.
 2. A bus accelerates uniformly from an initial velocity of $15 \text{ m}\cdot\text{s}^{-1}$ to a final velocity of $7 \text{ m}\cdot\text{s}^{-1}$ in 4 seconds. Calculate the acceleration of the bus. Let the direction of motion of the bus be the positive direction.
 3. An aeroplane accelerates uniformly from an initial velocity of $200 \text{ m}\cdot\text{s}^{-1}$ to a velocity of $100 \text{ m}\cdot\text{s}^{-1}$ in 10 seconds. It then accelerates uniformly to a final velocity of $240 \text{ m}\cdot\text{s}^{-1}$ in 20 seconds. Let the direction of motion of the aeroplane be the positive direction.
 - (a) Calculate the acceleration of the aeroplane during the first 10 seconds of the motion.
 - (b) Calculate the acceleration of the aeroplane during the next 14 seconds of its motion.
 - (c) Calculate the acceleration of the aeroplane during the whole 24 seconds of its motion.
-

3.6 Description of Motion

The purpose of this chapter is to describe motion, and now that we understand the definitions of displacement, distance, velocity, speed and acceleration, we are ready to start using these ideas to describe how an object is moving. There are many ways of describing motion:

1. words
2. diagrams
3. graphs

These methods will be described in this section.

We will consider three types of motion: when the object is not moving (stationary object), when the object is moving at a constant velocity (uniform motion) and when the object is moving at a constant acceleration (motion at constant acceleration).

3.6.1 Stationary Object

The simplest motion that we can come across is that of a stationary object. A stationary object does not move and so its position does not change, for as long as it is standing still. An example of this situation is when someone is waiting for something without moving. The person remains in the same position.

Lesedi is waiting for a taxi. He is standing two metres from a stop street at $t = 0$ s. After one minute, at $t = 60$ s, he is still 2 metres from the stop street and after two minutes, at $t = 120$ s, also 2 metres from the stop street. His position has not changed. His displacement is zero (because his position is the same), his velocity is zero (because his displacement is zero) and his acceleration is also zero (because his velocity is not changing).

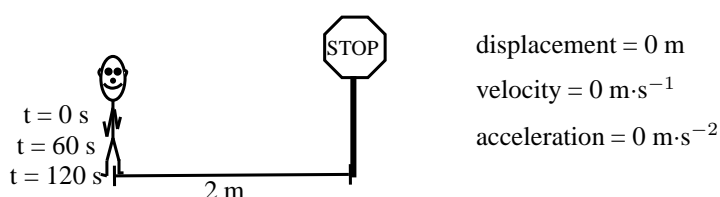

We can now draw graphs of position vs.time (x vs. t), velocity vs.time (v vs. t) and acceleration vs.time (a vs. t) for a stationary object. The graphs are shown in Figure 3.5. Lesedi's position is 2 metres from the stop street. If the stop street is taken as the reference point, his position remains at 2 metres for 120 seconds. The graph is a horizontal line at 2 m. The velocity and acceleration graphs are also shown. They are both horizontal lines on the x -axis. Since his position is not changing, his velocity is 0 m·s⁻¹ and since velocity is not changing acceleration is 0 m·s⁻².

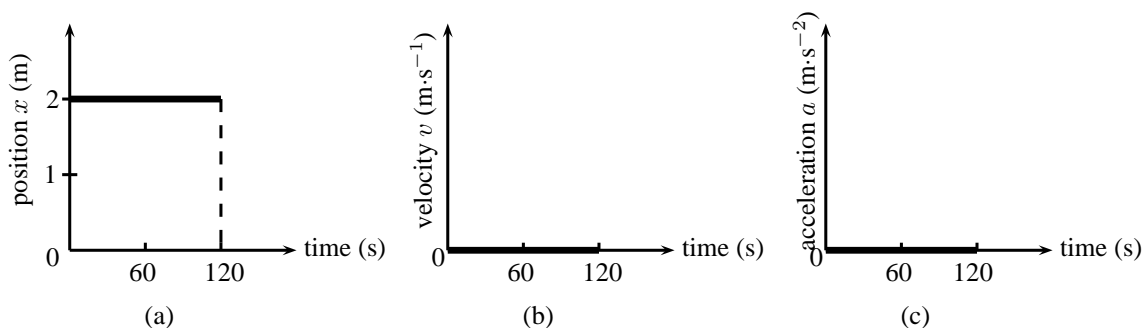

Figure 3.5: Graphs for a stationary object (a) position vs. time (b) velocity vs. time (c) acceleration vs. time.



Definition: Gradient

The gradient of a line can be calculated by dividing the change in the y -value by the change in the x -value.

$$m = \frac{\Delta y}{\Delta x}$$

Since we know that velocity is the rate of change of position, we can confirm the value for the velocity vs. time graph, by calculating the gradient of the x vs. t graph.

Important: The gradient of a position vs. time graph gives the velocity.

If we calculate the gradient of the x vs. t graph for a stationary object we get:

$$\begin{aligned} v &= \frac{\Delta x}{\Delta t} \\ &= \frac{x_f - x_i}{t_f - t_i} \\ &= \frac{2 \text{ m} - 2 \text{ m}}{120 \text{ s} - 60 \text{ s}} \quad (\text{initial position} = \text{final position}) \\ &= 0 \text{ m} \cdot \text{s}^{-1} \quad (\text{for the time that Lesedi is stationary}) \end{aligned}$$

Similarly, we can confirm the value of the acceleration by calculating the gradient of the velocity vs. time graph.

Important: The gradient of a velocity vs. time graph gives the acceleration.

If we calculate the gradient of the v vs. t graph for a stationary object we get:

$$\begin{aligned} a &= \frac{\Delta v}{\Delta t} \\ &= \frac{v_f - v_i}{t_f - t_i} \\ &= \frac{0 \text{ m} \cdot \text{s}^{-1} - 0 \text{ m} \cdot \text{s}^{-1}}{120 \text{ s} - 60 \text{ s}} \\ &= 0 \text{ m} \cdot \text{s}^{-2} \end{aligned}$$

Additionally, because the velocity vs. time graph is related to the position vs. time graph, we can use the area under the velocity vs. time graph to calculate the displacement of an object.

Important: The area under the velocity vs. time graph gives the displacement.

The displacement of the object is given by the area under the graph, which is 0 m. This is obvious, because the object is not moving.

3.6.2 Motion at Constant Velocity

Motion at a constant velocity or *uniform motion* means that the position of the object is changing at the same rate.

Assume that Lesedi takes 100 s to walk the 100 m to the taxi-stop every morning. If we assume that Lesedi's house is the origin, then Lesedi's velocity is:

$$\begin{aligned} v &= \frac{\Delta x}{\Delta t} \\ &= \frac{x_f - x_i}{t_f - t_i} \\ &= \frac{100 \text{ m} - 0 \text{ m}}{100 \text{ s} - 0 \text{ s}} \\ &= 1 \text{ m} \cdot \text{s}^{-1} \end{aligned}$$

Lesedi's velocity is $1 \text{ m} \cdot \text{s}^{-1}$. This means that he walked 1 m in the first second, another metre in the second second, and another in the third second, and so on. For example, after 50 s he will be 50 m from home. His position increases by 1 m every 1 s. A diagram of Lesedi's position is shown in Figure 3.6.

We can now draw graphs of position vs.time (x vs. t), velocity vs.time (v vs. t) and acceleration vs.time (a vs. t) for Lesedi moving at a constant velocity. The graphs are shown in Figure 3.7.

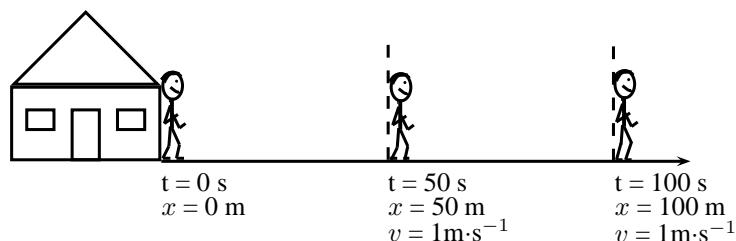

Figure 3.6: Diagram showing Lesedi's motion at a constant velocity of $1 \text{ m}\cdot\text{s}^{-1}$

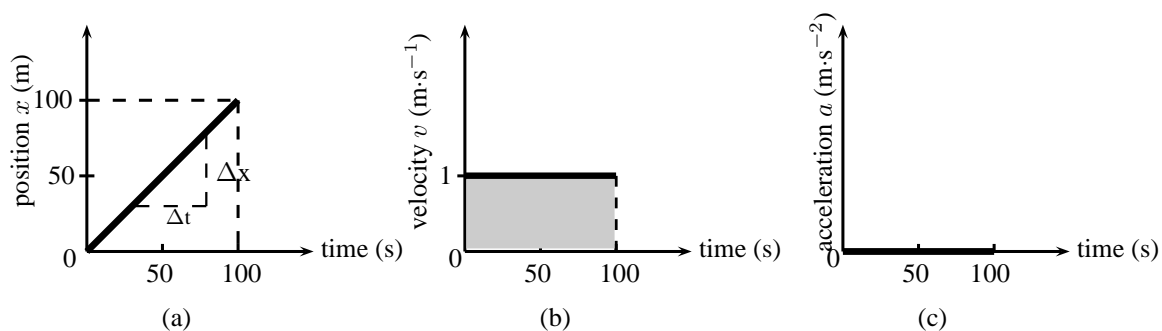

Figure 3.7: Graphs for motion at constant velocity (a) position vs. time (b) velocity vs. time (c) acceleration vs. time. The area of the shaded portion in the v vs. t graph corresponds to the object's displacement.

In the evening Lesedi walks 100 m from the bus stop to his house in 100 s. Assume that Lesedi's house is the origin. The following graphs can be drawn to describe the motion.

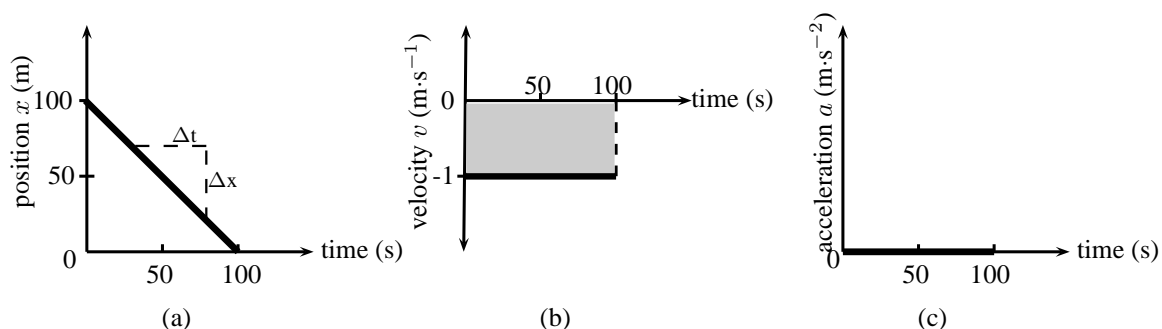

Figure 3.8: Graphs for motion with a constant negative velocity (a) position vs. time (b) velocity vs. time (c) acceleration vs. time. The area of the shaded portion in the v vs. t graph corresponds to the object's displacement.

We see that the v vs. t graph is a horizontal line. If the velocity vs. time graph is a horizontal line, it means that the velocity is *constant* (not changing). Motion at a constant velocity is known as *uniform motion*.

We can use the x vs. t to calculate the velocity by finding the gradient of the line.

$$\begin{aligned}
 v &= \frac{\Delta x}{\Delta t} \\
 &= \frac{x_f - x_i}{t_f - t_i} \\
 &= \frac{0 \text{ m} - 100 \text{ m}}{100 \text{ s} - 0 \text{ s}} \\
 &= -1 \text{ m}\cdot\text{s}^{-1}
 \end{aligned}$$

Lesedi has a velocity of $-1 \text{ m}\cdot\text{s}^{-1}$, or $1 \text{ m}\cdot\text{s}^{-1}$ towards his house. You will notice that the v vs. t graph is a horizontal line corresponding to a velocity of $-1 \text{ m}\cdot\text{s}^{-1}$. The horizontal line means that the velocity stays the same (remains constant) during the motion. This is uniform velocity.

We can use the v vs. t to calculate the acceleration by finding the gradient of the line.

$$\begin{aligned}
 a &= \frac{\Delta v}{\Delta t} \\
 &= \frac{v_f - v_i}{t_f - t_i} \\
 &= \frac{1 \text{ m}\cdot\text{s}^{-1} - 1 \text{ m}\cdot\text{s}^{-1}}{100 \text{ s} - 0 \text{ s}} \\
 &= 0 \text{ m}\cdot\text{s}^{-2}
 \end{aligned}$$

Lesedi has an acceleration of $0 \text{ m}\cdot\text{s}^{-2}$. You will notice that the graph of a vs. t is a horizontal line corresponding to an acceleration value of $0 \text{ m}\cdot\text{s}^{-2}$. There is no acceleration during the motion because his velocity does not change.

We can use the v vs. t to calculate the displacement by finding the area under the graph.

$$\begin{aligned}
 v &= \text{Area under graph} \\
 &= \ell \times b \\
 &= 100 \times (-1) \\
 &= -100 \text{ m}
 \end{aligned}$$

This means that Lesedi has a displacement of 100 m towards his house.



Exercise: Velocity and acceleration

- Use the graphs in Figure 3.7 to calculate each of the following:
 - Calculate Lesedi's velocity between 50 s and 100 s using the x vs. t graph. Hint: Find the gradient of the line.
 - Calculate Lesedi's acceleration during the whole motion using the v vs. t graph.
 - Calculate Lesedi's displacement during the whole motion using the v vs. t graph.
- Thandi takes 200 s to walk 100 m to the bus stop every morning. Draw a graph of Thandi's position as a function of time (assuming that Thandi's home is the reference point). Use the gradient of the x vs. t graph to draw the graph of velocity vs. time. Use the gradient of the v vs. t graph to draw the graph of acceleration vs. time.
- In the evening Thandi takes 200 s to walk 100 m from the bus stop to her home. Draw a graph of Thandi's position as a function of time (assuming that Thandi's home is the origin). Use the gradient of the x vs. t graph to draw the graph of velocity vs. time. Use the gradient of the v vs. t graph to draw the graph of acceleration vs. time.
- Discuss the differences between the two sets of graphs in questions 2 and 3.

Activity :: Experiment : Motion at constant velocity

Aim:

To measure the position and time during motion at constant velocity and determine the average velocity as the gradient of a "Position vs. Time" graph.

Apparatus:

A battery operated toy car, stopwatch, meter stick or measuring tape.

Method:

- Work with a friend. Copy the table below into your workbook.
- Complete the table by timing the car as it travels each distance.
- Time the car twice for each distance and take the average value as your accepted time.
- Use the distance and average time values to plot a graph of "Distance vs. Time" **onto graph paper**. Stick the graph paper into your workbook. (Remember that "A vs. B" always means "y vs. x").
- Insert all axis labels and units onto your graph.
- Draw the best straight line through your data points.
- Find the gradient of the straight line. This is the average velocity.

Results:

Distance (m)	Time (s)		
	1	2	Ave.
0			
0,5			
1,0			
1,5			
2,0			
2,5			
3,0			

Conclusions:

Answer the following questions in your workbook.

Questions:

1. Did the car travel with a constant velocity?
 2. How can you tell by looking at the "Distance vs. Time" graph if the velocity is constant?
 3. How would the "Distance vs. Time" look for a car with a faster velocity?
 4. How would the "Distance vs. Time" look for a car with a slower velocity?
-

3.6.3 Motion at Constant Acceleration

The final situation we will be studying is motion at constant acceleration. We know that acceleration is the rate of change of velocity. So, if we have a constant acceleration, this means that the velocity changes at a constant rate.

Let's look at our first example of Lesedi waiting at the taxi stop again. A taxi arrived and Lesedi got in. The taxi stopped at the stop street and then accelerated as follows: After 1 s the taxi covered a distance of 2,5 m, after 2 s it covered 10 m, after 3 seconds it covered 22,5 m and after 4 s it covered 40 m. The taxi is covering a larger distance every second. This means that it is accelerating.

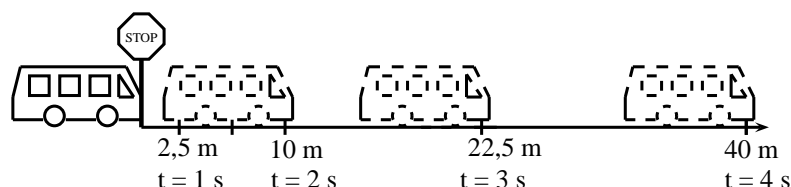

To calculate the velocity of the taxi you need to calculate the gradient of the line at each second:

$$\begin{aligned}
 v_{1s} &= \frac{\Delta x}{\Delta t} & v_{2s} &= \frac{\Delta x}{\Delta t} & v_{3s} &= \frac{\Delta x}{\Delta t} \\
 &= \frac{x_f - x_i}{t_f - t_i} & &= \frac{x_f - x_i}{t_f - t_i} & &= \frac{x_f - x_i}{t_f - t_i} \\
 &= \frac{5\text{m} - 0\text{m}}{1,5\text{s} - 0,5\text{s}} & &= \frac{15\text{m} - 5\text{m}}{2,5\text{s} - 1,5\text{s}} & &= \frac{30\text{m} - 15\text{m}}{3,5\text{s} - 2,5\text{s}} \\
 &= 5\text{ m} \cdot \text{s}^{-1} & &= 10\text{ m} \cdot \text{s}^{-1} & &= 15\text{ m} \cdot \text{s}^{-1}
 \end{aligned}$$

From these velocities, we can draw the velocity-time graph which forms a straight line.

The acceleration is the gradient of the v vs. t graph and can be calculated as follows:

$$\begin{aligned}
 a &= \frac{\Delta v}{\Delta t} \\
 &= \frac{v_f - v_i}{t_f - t_i} \\
 &= \frac{15\text{m} \cdot \text{s}^{-1} - 5\text{m} \cdot \text{s}^{-1}}{3\text{s} - 1\text{s}} \\
 &= 5\text{ m} \cdot \text{s}^{-2}
 \end{aligned}$$

The acceleration does not change during the motion (the gradient stays constant). This is motion at constant or uniform acceleration.

The graphs for this situation are shown in Figure 3.9.

Velocity from Acceleration vs. Time Graphs

Just as we used velocity vs. time graphs to find displacement, we can use acceleration vs. time graphs to find the velocity of an object at a given moment in time. We simply calculate the area under the acceleration vs. time graph, at a given time. In the graph below, showing an object at a constant positive acceleration, the increase in velocity of the object after 2 seconds corresponds to the shaded portion.

$$\begin{aligned}
 v &= \text{area of rectangle} = a \times \Delta t \\
 &= 5\text{ m} \cdot \text{s}^{-2} \times 2\text{ s} \\
 &= 10\text{ m} \cdot \text{s}^{-1}
 \end{aligned}$$

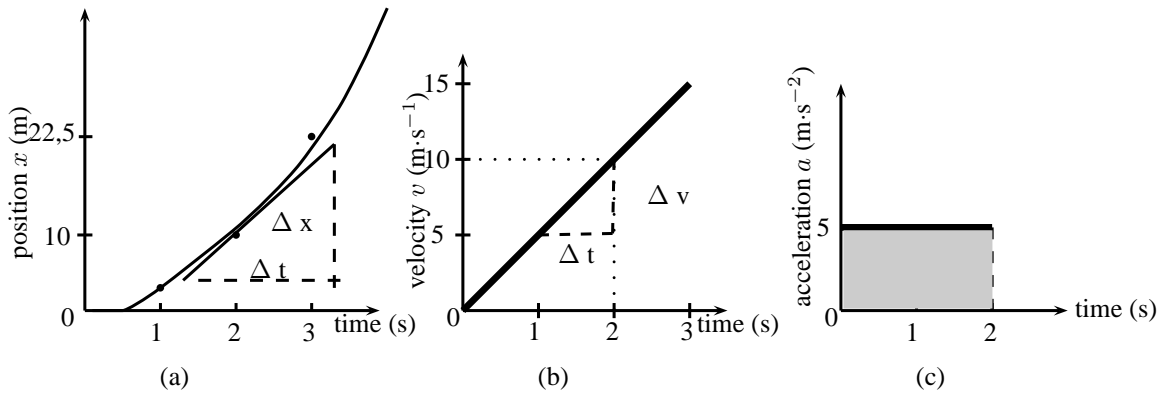

Figure 3.9: Graphs for motion with a constant acceleration (a) position vs. time (b) velocity vs. time (c) acceleration vs. time.

The velocity of the object at $t = 2$ s is therefore $10 \text{ m}\cdot\text{s}^{-1}$. This corresponds with the values obtained in Figure 3.9.



Exercise: Graphs

1. A car is parked 10 m from home for 10 minutes. Draw a displacement-time, velocity-time and acceleration-time graphs for the motion. Label all the axes.
2. A bus travels at a constant velocity of $12 \text{ m}\cdot\text{s}^{-1}$ for 6 seconds. Draw the displacement-time, velocity-time and acceleration-time graph for the motion. Label all the axes.
3. An athlete runs with a constant acceleration of $1 \text{ m}\cdot\text{s}^{-2}$ for 4 s. Draw the acceleration-time, velocity-time and displacement time graphs for the motion. Accurate values are only needed for the acceleration-time and velocity-time graphs.
4. The following velocity-time graph describes the motion of a car. Draw the displacement-time graph and the acceleration-time graph and explain the motion of the car according to the three graphs.

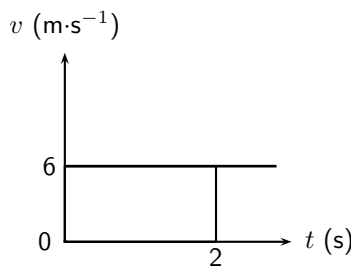

5. The following velocity-time graph describes the motion of a truck. Draw the displacement-time graph and the acceleration-time graph and explain the motion of the truck according to the three graphs.

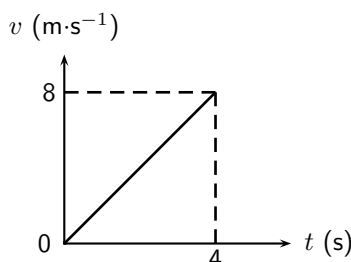

3.7 Summary of Graphs

The relation between graphs of position, velocity and acceleration as functions of time is summarised in Figure 3.10.

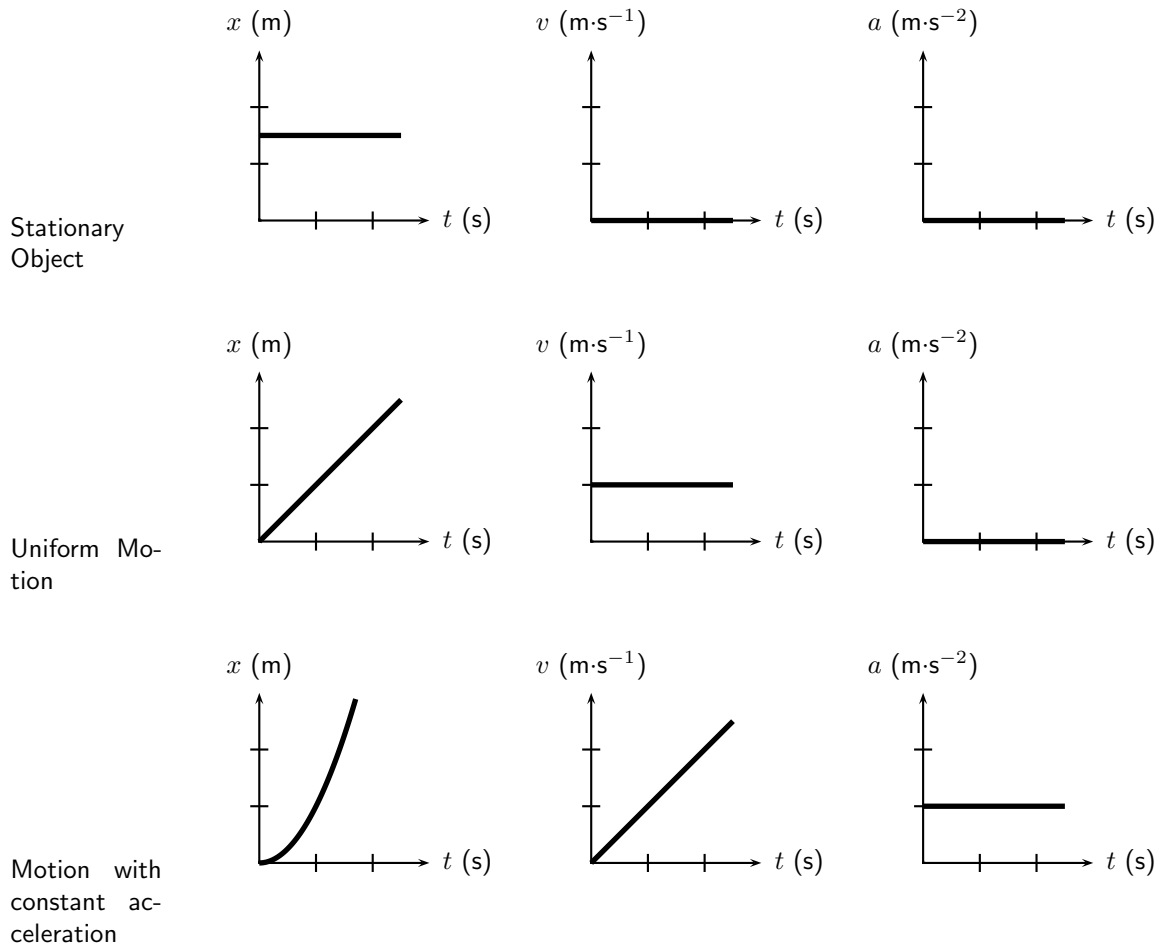

Figure 3.10: Position-time, velocity-time and acceleration-time graphs.



Important: Often you will be required to describe the motion of an object that is presented as a graph of either position, velocity or acceleration as functions of time. The description of the motion represented by a graph should include the following (where possible):

1. whether the object is moving in the positive or negative direction
2. whether the object is at rest, moving at constant velocity or moving at constant positive acceleration (speeding up) or constant negative acceleration (slowing down)

You will also often be required to draw graphs based on a description of the motion in words or from a diagram. Remember that these are just different methods of presenting the same information. If you keep in mind the general shapes of the graphs for the different types of motion, there should not be any difficulty with explaining what is happening.

3.8 Worked Examples

The worked examples in this section demonstrate the types of questions that can be asked about graphs.



Worked Example 8: Description of motion based on a position-time graph

Question: The position vs. time graph for the motion of a car is given below. Draw the corresponding velocity vs. time and acceleration vs. time graphs, and then describe the motion of the car.

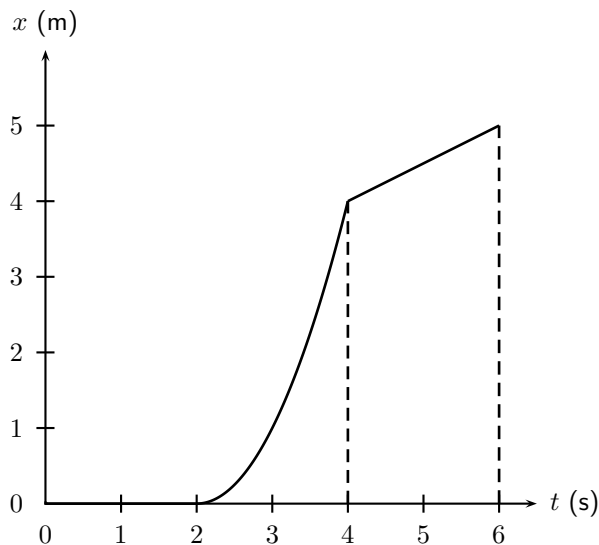

Answer

Step 1 : Identify what information is given and what is asked for

The question gives a position vs. time graph and the following three things are required:

1. Draw a v vs. t graph.
2. Draw an a vs. t graph.
3. Describe the motion of the car.

To answer these questions, break the motion up into three sections: 0 - 2 seconds, 2 - 4 seconds and 4 - 6 seconds.

Step 2 : Velocity vs. time graph for 0-2 seconds

For the first 2 seconds we can see that the displacement remains constant - so the object is not moving, thus it has zero velocity during this time. We can reach this conclusion by another path too: remember that the gradient of a displacement vs. time graph is the velocity. For the first 2 seconds we can see that the displacement vs. time graph is a horizontal line, ie. it has a gradient of zero. Thus the velocity during this time is zero and the object is stationary.

Step 3 : Velocity vs. time graph for 2-4 seconds

For the next 2 seconds, displacement is increasing with time so the object is moving. Looking at the gradient of the displacement graph we can see that it is not constant. In fact, the slope is getting steeper (the gradient is increasing) as time goes on. Thus, remembering that the gradient of a displacement vs. time graph is the velocity, the velocity must be increasing with time during this phase.

Step 4 : Velocity vs. time graph for 4-6 seconds

For the final 2 seconds we see that displacement is still increasing with time, but this time the gradient is constant, so we know that the object is now travelling at a constant velocity, thus the velocity vs. time graph will be a horizontal line during this stage. We can now draw the graphs:

So our velocity vs. time graph looks like this one below. Because we haven't been given any values on the vertical axis of the displacement vs. time graph, we cannot figure out what the exact gradients are and therefore what the values of the velocities are. In this type of question it is just important to show whether velocities are positive or negative, increasing, decreasing or constant.

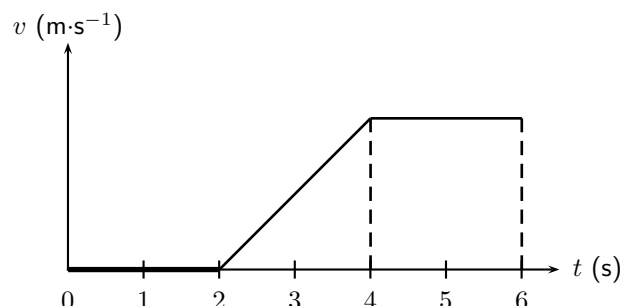

Once we have the velocity vs. time graph its much easier to get the acceleration vs. time graph as we know that the gradient of a velocity vs. time graph is the just the acceleration.

Step 5 : Acceleration vs. time graph for 0-2 seconds

For the first 2 seconds the velocity vs. time graph is horizontal and has a value of zero, thus it has a gradient of zero and there is no acceleration during this time. (This makes sense because we know from the displacement time graph that the object is stationary during this time, so it can't be accelerating).

Step 6 : Acceleration vs. time graph for 2-4 seconds

For the next 2 seconds the velocity vs. time graph has a positive gradient. This gradient is not changing (i.e. its constant) throughout these 2 seconds so there must be a constant positive acceleration.

Step 7 : Acceleration vs. time graph for 4-6 seconds

For the final 2 seconds the object is traveling with a constant velocity. During this time the gradient of the velocity vs. time graph is once again zero, and thus the object is not accelerating. The acceleration vs. time graph looks like this:

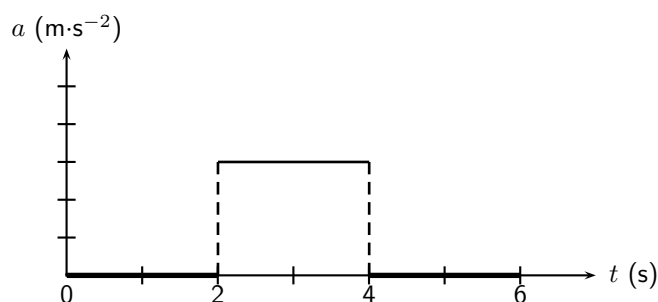

Step 8 : A description of the object's motion

A brief description of the motion of the object could read something like this: At $t = 0$ s and object is stationary at some position and remains stationary until $t = 2$ s when it begins accelerating. It accelerates in a positive direction for 2 seconds until $t = 4$ s and then travels at a constant velocity for a further 2 seconds.



Worked Example 9: Calculations from a velocity vs. time graph

Question: The velocity vs. time graph of a truck is plotted below. Calculate the distance and displacement of the truck after 15 seconds.

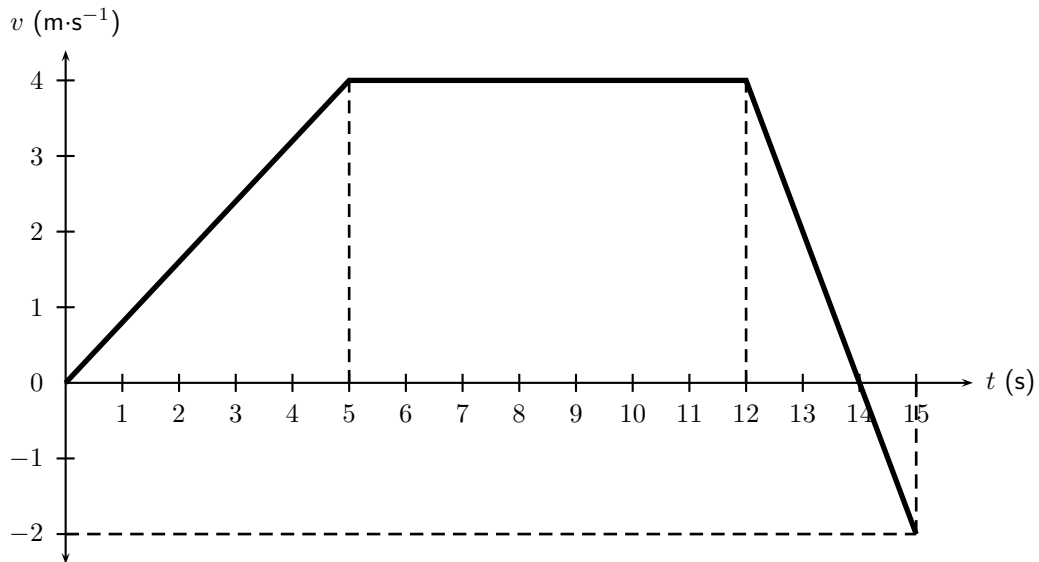

Answer

Step 1 : Decide how to tackle the problem

We are asked to calculate the distance and displacement of the car. All we need to remember here is that we can use the area between the velocity vs. time graph and the time axis to determine the distance and displacement.

Step 2 : Determine the area under the velocity vs. time graph

Break the motion up: 0 - 5 seconds, 5 - 12 seconds, 12 - 14 seconds and 14 - 15 seconds.

For 0 - 5 seconds: The displacement is equal to the area of the triangle on the left:

$$\begin{aligned} \text{Area}_{\triangle} &= \frac{1}{2} b \times h \\ &= \frac{1}{2} \times 5 \times 4 \\ &= 10 \text{ m} \end{aligned}$$

For 5 - 12 seconds: The displacement is equal to the area of the rectangle:

$$\begin{aligned} \text{Area}_{\square} &= \ell \times b \\ &= 7 \times 4 \\ &= 28 \text{ m} \end{aligned}$$

For 12 - 14 seconds the displacement is equal to the area of the triangle above the time axis on the right:

$$\begin{aligned} \text{Area}_{\triangle} &= \frac{1}{2} b \times h \\ &= \frac{1}{2} \times 2 \times 4 \\ &= 4 \text{ m} \end{aligned}$$

For 14 - 15 seconds the displacement is equal to the area of the triangle below the time axis:

$$\begin{aligned} \text{Area}_{\triangle} &= \frac{1}{2} b \times h \\ &= \frac{1}{2} \times 1 \times 2 \\ &= 1 \text{ m} \end{aligned}$$

Step 3 : Determine the total distance of the car

Now the total distance of the car is the sum of all of these areas:

$$\begin{aligned} \Delta x &= 10 + 28 + 4 + 1 \\ &= 43 \text{ m} \end{aligned}$$

Step 4 : Determine the total displacement of the car

Now the total displacement of the car is just the sum of all of these areas. HOWEVER, because in the last second (from $t = 14$ s to $t = 15$ s) the velocity of the car is negative, it means that the car was going in the opposite direction, i.e. back where it came from! So, to find the total displacement, we have to add the first 3 areas (those with positive displacements) and subtract the last one (because it is a displacement in the opposite direction).

$$\begin{aligned}\Delta x &= 10 + 28 + 4 - 1 \\ &= 41 \text{ m in the positive direction}\end{aligned}$$

**Worked Example 10: Velocity from a position vs. time graph**

Question: The position vs. time graph below describes the motion of an athlete.

1. What is the velocity of the athlete during the first 4 seconds?
2. What is the velocity of the athlete from $t = 4$ s to $t = 7$ s?

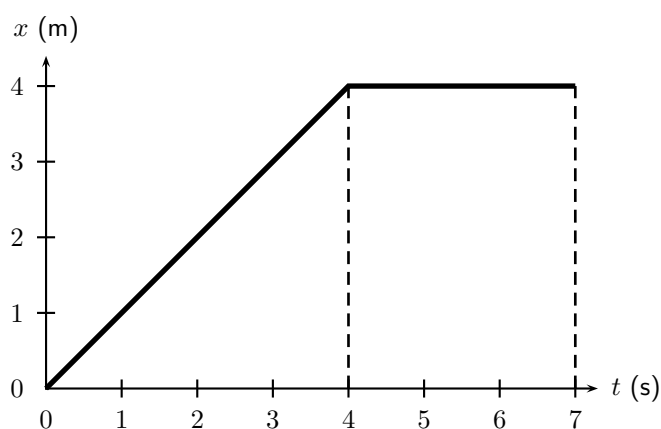
**Answer****Step 1 : The velocity during the first 4 seconds**

The velocity is given by the gradient of a position vs. time graph. During the first 4 seconds, this is

$$\begin{aligned}v &= \frac{\Delta x}{\Delta t} \\ &= \frac{4 - 0}{4 - 0} \\ &= 1 \text{ m} \cdot \text{s}^{-1}\end{aligned}$$

Step 2 : The velocity during the last 3 seconds

For the last 3 seconds we can see that the displacement stays constant. The graph shows a horizontal line and therefore the gradient is zero. Thus $v = 0 \text{ m} \cdot \text{s}^{-1}$.

Worked Example 11: Drawing a v vs. t graph from an a vs. t graph

Question: The acceleration vs. time graph for a car starting from rest, is given below. Calculate the velocity of the car and hence draw the velocity vs. time graph.

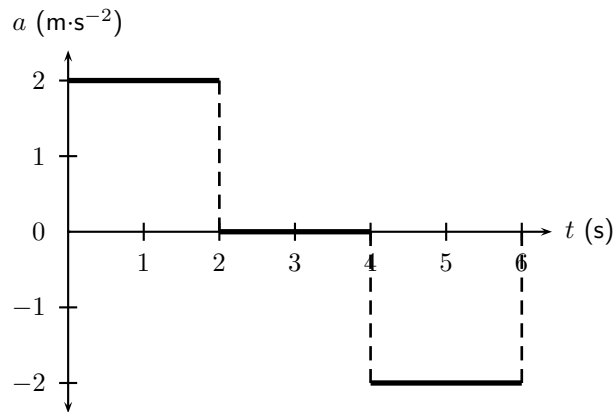
Answer

Step 1 : Calculate the velocity values by using the area under each part of the graph.

The motion of the car can be divided into three time sections: 0 - 2 seconds; 2 - 4 seconds and 4 - 6 seconds. To be able to draw the velocity vs. time graph, the velocity for each time section needs to be calculated. The velocity is equal to the area of the square under the graph:

For 0 - 2 seconds:

$$\begin{aligned} \text{Area}\square &= \ell \times b \\ &= 2 \times 2 \\ &= 4 \text{ m} \cdot \text{s}^{-1} \end{aligned}$$

The velocity of the car is $4 \text{ m} \cdot \text{s}^{-1}$ at $t = 2\text{s}$.

For 2 - 4 seconds:

$$\begin{aligned} \text{Area}\square &= \ell \times b \\ &= 2 \times 0 \\ &= 0 \text{ m} \cdot \text{s}^{-1} \end{aligned}$$

The velocity of the car is $0 \text{ m} \cdot \text{s}^{-1}$ from $t = 2 \text{ s}$ to $t = 4 \text{ s}$.

For 4 - 6 seconds:

$$\begin{aligned} \text{Area}\square &= \ell \times b \\ &= 2 \times -2 \\ &= -4 \text{ m} \cdot \text{s}^{-1} \end{aligned}$$

The acceleration had a negative value, which means that the velocity is decreasing. It starts at a velocity of $4 \text{ m} \cdot \text{s}^{-1}$ and decreases to $0 \text{ m} \cdot \text{s}^{-1}$.

Step 2 : Now use the values to draw the velocity vs. time graph.

The velocity vs. time graph looks like this:

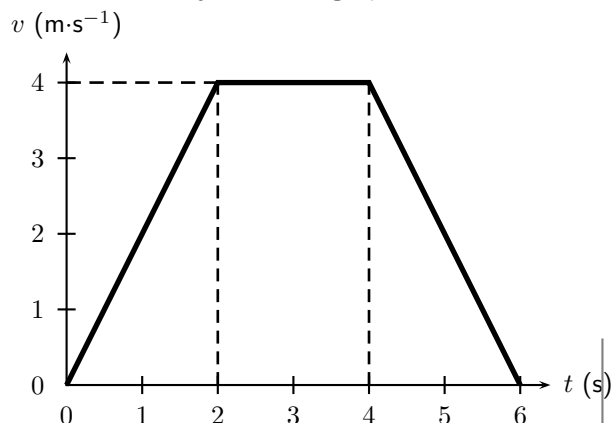

3.9 Equations of Motion

In this chapter we will look at the third way to describe motion. We have looked at describing motion in terms of graphs and words. In this section we examine equations that can be used to describe motion.

This section is about solving problems relating to uniformly accelerated motion. In other words, motion at constant acceleration.

The following are the variables that will be used in this section:

v_i	=	initial velocity ($\text{m}\cdot\text{s}^{-1}$) at $t = 0$ s
v_f	=	final velocity ($\text{m}\cdot\text{s}^{-1}$) at time t
Δx	=	displacement (m)
t	=	time (s)
Δt	=	time interval (s)
a	=	acceleration ($\text{m}\cdot\text{s}^{-2}$)

$$v_f = v_i + at \quad (3.1)$$

$$\Delta x = \frac{(v_i + v_f)t}{2} \quad (3.2)$$

$$\Delta x = v_i t + \frac{1}{2}at^2 \quad (3.3)$$

$$v_f^2 = v_i^2 + 2a\Delta x \quad (3.4)$$

The questions can vary a lot, but the following method for answering them will always work. Use this when attempting a question that involves motion with constant acceleration. You need any three known quantities (v_i , v_f , Δx , t or a) to be able to calculate the fourth one.

1. Read the question carefully to identify the quantities that are given. Write them down.
2. Identify the equation to use. *Write it down!!!*
3. Ensure that all the values are in the correct unit and fill them in your equation.
4. Calculate the answer and fill in its unit.

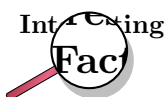

Galileo Galilei of Pisa, Italy, was the first to determine the correct mathematical law for acceleration: the total distance covered, starting from rest, is proportional to the square of the time. He also concluded that objects retain their velocity unless a force – often friction – acts upon them, refuting the accepted Aristotelian hypothesis that objects "naturally" slow down and stop unless a force acts upon them. This principle was incorporated into Newton's laws of motion (1st law).

3.9.1 Finding the Equations of Motion

The following does not form part of the syllabus and can be considered additional information.

Derivation of Equation 3.1

According to the definition of acceleration:

$$a = \frac{\Delta v}{t}$$

where Δv is the change in velocity, i.e. $\Delta v = v_f - v_i$. Thus we have

$$\begin{aligned} a &= \frac{v_f - v_i}{t} \\ v_f &= v_i + at \end{aligned}$$

Derivation of Equation 3.2

We have seen that displacement can be calculated from the area under a velocity vs. time graph. For *uniformly accelerated motion* the most complicated velocity vs. time graph we can have is a straight line. Look at the graph below - it represents an object with a starting velocity of v_i , accelerating to a final velocity v_f over a total time t .

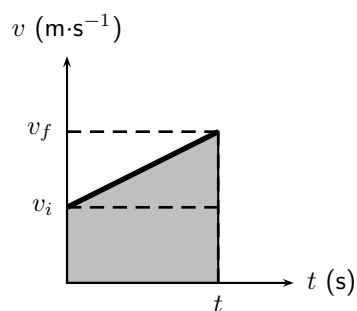

To calculate the final displacement we must calculate the area under the graph - this is just the area of the rectangle added to the area of the triangle. This portion of the graph has been shaded for clarity.

$$\begin{aligned} \text{Area}\triangle &= \frac{1}{2}b \times h \\ &= \frac{1}{2}t \times (v_f - v_i) \\ &= \frac{1}{2}v_f t - \frac{1}{2}v_i t \end{aligned}$$

$$\begin{aligned} \text{Area}\square &= \ell \times b \\ &= t \times v_i \\ &= v_i t \end{aligned}$$

$$\begin{aligned} \text{Displacement} &= \text{Area}\square + \text{Area}\triangle \\ \Delta x &= v_i t + \frac{1}{2}v_f t - \frac{1}{2}v_i t \\ \Delta x &= \frac{(v_i + v_f)t}{2} \end{aligned}$$

Derivation of Equation 3.3

This equation is simply derived by eliminating the final velocity v_f in equation 3.2. Remembering from equation 3.1 that

$$v_f = v_i + at$$

then equation 3.2 becomes

$$\begin{aligned}\Delta x &= \frac{v_i + v_i + at}{2}t \\ &= \frac{2v_it + at^2}{2} \\ \Delta x &= v_it + \frac{1}{2}at^2\end{aligned}$$

Derivation of Equation 3.4

This equation is just derived by eliminating the time variable in the above equation. From Equation 3.1 we know

$$t = \frac{v_f - v_i}{a}$$

Substituting this into Equation 3.3 gives

$$\begin{aligned} \Delta x &= v_i \left(\frac{v_f - v_i}{a} \right) + \frac{1}{2} a \left(\frac{v_f - v_i}{a} \right)^2 \\ &= \frac{v_i v_f}{a} - \frac{v_i^2}{a} + \frac{1}{2} a \left(\frac{v_f^2 - 2v_i v_f + v_i^2}{a^2} \right) \\ &= \frac{v_i v_f}{a} - \frac{v_i^2}{a} + \frac{v_f^2}{2a} - \frac{v_i v_f}{a} + \frac{v_i^2}{2a} \\ 2a\Delta x &= -2v_i^2 + v_f^2 + v_i^2 \\ v_f^2 &= v_i^2 + 2a\Delta x \end{aligned} \quad (3.5)$$

This gives us the final velocity in terms of the initial velocity, acceleration and displacement and is independent of the time variable.

**Worked Example 12: Equations of motion**

Question: A racing car is travelling north. It accelerates uniformly covering a distance of 725 m in 10 s. If it has an initial velocity of $10 \text{ m}\cdot\text{s}^{-1}$, find its acceleration.

Answer

Step 1 : Identify what information is given and what is asked for

We are given:

$$\begin{aligned} v_i &= 10 \text{ m}\cdot\text{s}^{-1} \\ \Delta x &= 725 \text{ m} \\ t &= 10 \text{ s} \\ a &= ? \end{aligned}$$

Step 2 : Find an equation of motion relating the given information to the acceleration

If you struggle to find the correct equation, find the quantity that is not given and then look for an equation that does not have this quantity in it.

We can use equation 3.3

$$\Delta x = v_i t + \frac{1}{2} a t^2$$

Step 3 : Substitute your values in and find the answer

$$\begin{aligned} \Delta x &= v_i t + \frac{1}{2} a t^2 \\ 725 &= (10 \times 10) + \frac{1}{2} a \times (10)^2 \\ 725 - 100 &= 50 a \\ a &= 12,5 \text{ m}\cdot\text{s}^{-2} \end{aligned}$$

Step 4 : Quote the final answer

The racing car is accelerating at $12,5 \text{ m}\cdot\text{s}^{-2}$ north.



Worked Example 13: Equations of motion

Question: A motorcycle, travelling east, starts from rest, moves in a straight line with a constant acceleration and covers a distance of 64 m in 4 s. Calculate

- its acceleration
- its final velocity
- at what time the motorcycle had covered half the total distance
- what distance the motorcycle had covered in half the total time.

Answer

Step 1 : Identify what information is given and what is asked for

We are given:

$$\begin{aligned}v_i &= 0 \text{ m} \cdot \text{s}^{-1} \text{ (because the object starts from rest.)} \\ \Delta x &= 64 \text{ m} \\ t &= 4 \text{ s} \\ a &= ? \\ v_f &= ? \\ t &= ? \text{ at half the distance } \Delta x = 32 \text{ m.} \\ \Delta x &= ? \text{ at half the time } t = 2 \text{ s.}\end{aligned}$$

All quantities are in SI units.

Step 2 : Acceleration: Find a suitable equation to calculate the acceleration

We can use equations 3.3

$$\Delta x = v_i t + \frac{1}{2} a t^2$$

Step 3 : Substitute the values and calculate the acceleration

$$\begin{aligned}\Delta x &= v_i t + \frac{1}{2} a t^2 \\ 64 &= (0 \times 4) + \frac{1}{2} a \times (4)^2 \\ 64 &= 8a \\ a &= 8 \text{ m} \cdot \text{s}^{-2} \text{ east}\end{aligned}$$

Step 4 : Final velocity: Find a suitable equation to calculate the final velocity

We can use equation 3.1 - remember we now also know the acceleration of the object.

$$v_f = v_i + at$$

Step 5 : Substitute the values and calculate the final velocity

$$\begin{aligned}v_f &= v_i + at \\ v_f &= 0 + (8)(4) \\ &= 32 \text{ m} \cdot \text{s}^{-1} \text{ east}\end{aligned}$$

Step 6 : Time at half the distance: Find an equation to calculate the time

We can use equation 3.3:

$$\begin{aligned}\Delta x &= v_i + \frac{1}{2} a t^2 \\ 32 &= (0)t + \frac{1}{2} (8)(t)^2 \\ 32 &= 0 + 4t^2 \\ 8 &= t^2 \\ t &= 2,83 \text{ s}\end{aligned}$$

Step 7 : Distance at half the time: Find an equation to relate the distance and time

Half the time is 2 s, thus we have v_i , a and t - all in the correct units. We can use equation 3.3 to get the distance:

$$\begin{aligned}\Delta x &= v_i t + \frac{1}{2} a t^2 \\ &= (0)(2) + \frac{1}{2}(8)(2)^2 \\ &= 16 \text{ m east}\end{aligned}$$

**Exercise: Acceleration**

1. A car starts off at $10 \text{ m}\cdot\text{s}^{-1}$ and accelerates at $1 \text{ m}\cdot\text{s}^{-2}$ for 10 s. What is its final velocity?
2. A train starts from rest, and accelerates at $1 \text{ m}\cdot\text{s}^{-2}$ for 10 s. How far does it move?
3. A bus is going $30 \text{ m}\cdot\text{s}^{-1}$ and stops in 5 s. What is its stopping distance for this speed?
4. A racing car going at $20 \text{ m}\cdot\text{s}^{-1}$ stops in a distance of 20 m. What is its acceleration?
5. A ball has a uniform acceleration of $4 \text{ m}\cdot\text{s}^{-1}$. Assume the ball starts from rest. Determine the velocity and displacement at the end of 10 s.
6. A motorcycle has a uniform acceleration of $4 \text{ m}\cdot\text{s}^{-1}$. Assume the motorcycle has an initial velocity of $20 \text{ m}\cdot\text{s}^{-1}$. Determine the velocity and displacement at the end of 12 s.
7. An aeroplane accelerates uniformly such that it goes from rest to $144 \text{ km}\cdot\text{hr}^{-1}$ in 8 s. Calculate the acceleration required and the total distance that it has traveled in this time.

3.10 Applications in the Real-World

What we have learnt in this chapter can be directly applied to road safety. We can analyse the relationship between speed and stopping distance. The following worked example illustrates this application.

Worked Example 14: Stopping distance

Question: A truck is travelling at a constant velocity of $10 \text{ m}\cdot\text{s}^{-1}$ when the driver sees a child 50 m in front of him in the road. He hits the brakes to stop the truck. The truck accelerates at a rate of $-1.25 \text{ m}\cdot\text{s}^{-2}$. His reaction time to hit the brakes is 0,5 seconds. Will the truck hit the child?

Answer

Step 1 : Analyse the problem and identify what information is given

It is useful to draw a timeline like this one:

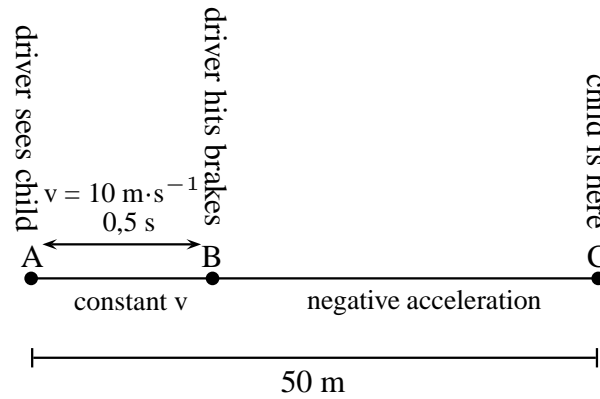

We need to know the following:

- What distance the driver covers before hitting the brakes.
- How long it takes the truck to stop after hitting the brakes.
- What total distance the truck covers to stop.

Step 2 : Calculate the distance AB

Before the driver hits the brakes, the truck is travelling at constant velocity. There is no acceleration and therefore the equations of motion are not used. To find the distance traveled, we use:

$$v = \frac{d}{t}$$

$$10 = \frac{d}{0,5}$$

$$d = 5 \text{ m}$$

The truck covers 5 m before the driver hits the brakes.

Step 3 : Calculate the time BC

We have the following for the motion between B and C:

$$v_i = 10 \text{ m} \cdot \text{s}^{-1}$$

$$v_f = 0 \text{ m} \cdot \text{s}^{-1}$$

$$a = -1,25 \text{ m} \cdot \text{s}^{-2}$$

$$t = ?$$

We can use equation 3.1

$$v_f = v_i + at$$

$$0 = 10 + (-1,25)t$$

$$-10 = -1,25t$$

$$t = 8 \text{ s}$$

Step 4 : Calculate the distance BC

For the distance we can use equation 3.2 or equation 3.3. We will use equation 3.2:

$$\Delta x = \frac{(v_i + v_f)t}{2}$$

$$\Delta x = \frac{10 + 0}{2}(8)$$

$$\Delta x = 40 \text{ m}$$

Step 5 : Write the final answer

The total distance that the truck covers is $d_{AB} + d_{BC} = 5 + 40 = 45$ meters. The child is 50 meters ahead. The truck will not hit the child.

3.11 Summary

- A reference point is a point from where you take your measurements.
- A frame of reference is a reference point with a set of directions.
- Your position is where you are located with respect to your reference point.
- The displacement of an object is how far it is from the reference point. It is the shortest distance between the object and the reference point. It has magnitude and direction because it is a vector.
- The distance of an object is the length of the path travelled from the starting point to the end point. It has magnitude only because it is a scalar.
- A vector is a physical quantity with magnitude and direction.
- A scalar is a physical quantity with magnitude only.
- Speed (s) is the distance covered (d) divided by the time taken (Δt):

$$s = \frac{d}{\Delta t}$$

- Average velocity (v) is the displacement (Δx) divided by the time taken (Δt):

$$v = \frac{\Delta x}{\Delta t}$$

- Instantaneous speed is the speed at a specific instant in time.
- Instantaneous velocity is the velocity at a specific instant in time.
- Acceleration (a) is the change in velocity (Δv) over a time interval (Δt):

$$a = \frac{\Delta v}{\Delta t}$$

- The gradient of a position - time graph (x vs. t) give the velocity.
- The gradient of a velocity - time graph (v vs. t) give the acceleration.
- The area under a velocity - time graph (v vs. t) give the displacement.
- The area under an acceleration - time graph (a vs. t) gives the velocity.
- The graphs of motion are summarised in figure 3.10.
- The equations of motion are used where constant acceleration takes place:

$$\begin{aligned} v_f &= v_i + at \\ \Delta x &= \frac{(v_i + v_f)t}{2} \\ \Delta x &= v_i t + \frac{1}{2}at^2 \\ v_f^2 &= v_i^2 + 2a\Delta x \end{aligned}$$

3.12 End of Chapter Exercises: Motion in One Dimension

- Give one word/term for the following descriptions.
 - The shortest path from start to finish.
 - A physical quantity with magnitude and direction.
 - The quantity defined as a change in velocity over a time period.
 - The point from where you take measurements.
 - The distance covered in a time interval.
 - The velocity at a specific instant in time.
- Choose an item from column B that match the description in column A. Write down only the letter next to the question number. You may use an item from column B more than once.

Column A	Column B
a. The area under a velocity - time graph	gradient
b. The gradient of a velocity - time graph	area
c. The area under an acceleration - time graph	velocity
d. The gradient of a displacement - time graph	displacement
	acceleration
	slope

- Indicate whether the following statements are TRUE or FALSE. Write only 'true' or 'false'. If the statement is false, write down the correct statement.
 - A scalar is the displacement of an object over a time interval.
 - The position of an object is where it is located.
 - The sign of the velocity of an object tells us in which direction it is travelling.
 - The acceleration of an object is the change of its displacement over a period in time.
- [SC 2003/11] A body accelerates uniformly from rest for t_0 seconds after which it continues with a constant velocity. Which graph is the correct representation of the body's motion?

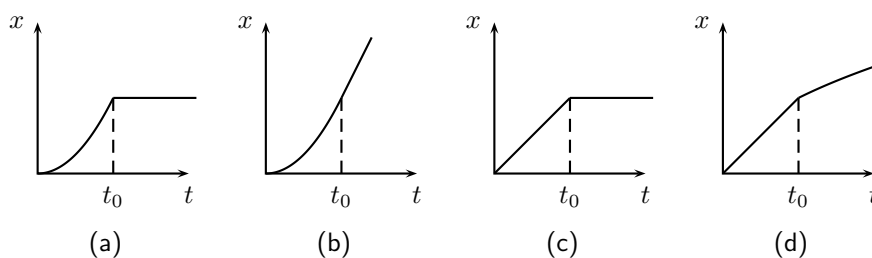

- [SC 2003/11] The velocity-time graphs of two cars are represented by P and Q as shown

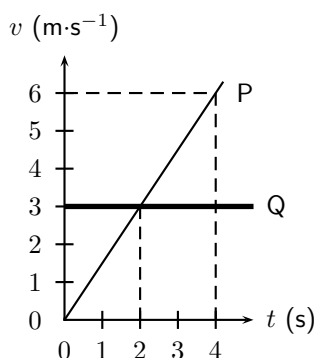

The difference in the distance travelled by the two cars (in m) after 4 s is ...

- (a) 12
- (b) 6
- (c) 2
- (d) 0

6. [IEB 2005/11 HG] The graph that follows shows how the speed of an athlete varies with time as he sprints for 100 m.

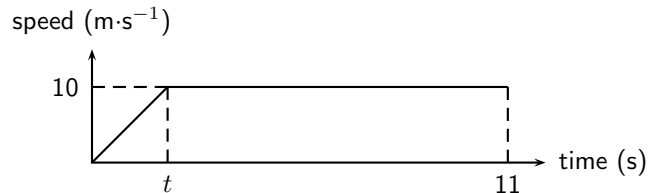

Which of the following equations can be used to correctly determine the time t for which he accelerates?

- (a) $100 = (10)(11) - \frac{1}{2}(10)t$
 - (b) $100 = (10)(11) + \frac{1}{2}(10)t$
 - (c) $100 = 10t + \frac{1}{2}(10)t^2$
 - (d) $100 = \frac{1}{2}(0)t + \frac{1}{2}(10)t^2$
7. [SC 2002/03 HG1] In which one of the following cases will the distance covered and the magnitude of the displacement be the same?
- (a) A girl climbs a spiral staircase.
 - (b) An athlete completes one lap in a race.
 - (c) A raindrop falls in still air.
 - (d) A passenger in a train travels from Cape Town to Johannesburg.
8. [SC 2003/11] A car, travelling at constant velocity, passes a stationary motor cycle at a traffic light. As the car overtakes the motorcycle, the motorcycle accelerates uniformly from rest for 10 s. The following displacement-time graph represents the motions of both vehicles from the traffic light onwards.

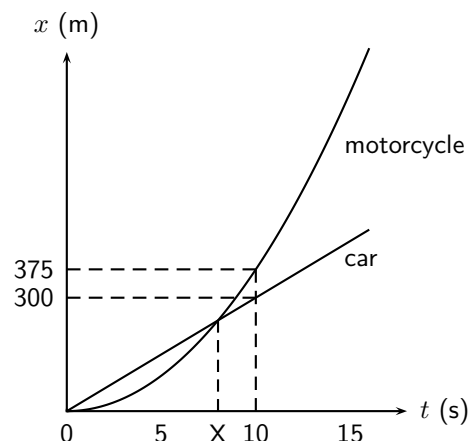

- (a) Use the graph to find the magnitude of the constant velocity of the car.
- (b) Use the information from the graph to show by means of calculation that the magnitude of the acceleration of the motorcycle, for the first 10 s of its motion is $7,5 \text{ m}\cdot\text{s}^{-2}$.
- (c) Calculate how long (in seconds) it will take the motorcycle to catch up with the car (point X on the time axis).
- (d) How far behind the motorcycle will the car be after 15 seconds?

9. [IEB 2005/11 HG] Which of the following statements is **true** of a body that accelerates uniformly?
- Its rate of change of position with time remains constant.
 - Its position changes by the same amount in equal time intervals.
 - Its velocity increases by increasing amounts in equal time intervals.
 - Its rate of change of velocity with time remains constant.
10. [IEB 2003/11 HG1] The velocity-time graph for a car moving along a straight horizontal road is shown below.

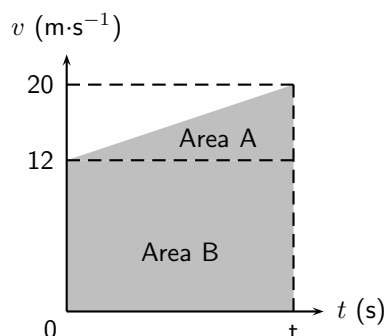

Which of the following expressions gives the magnitude of the average velocity of the car?

- $\frac{\text{AreaA}}{t}$
 - $\frac{\text{AreaA} + \text{AreaB}}{t}$
 - $\frac{\text{AreaB}}{t}$
 - $\frac{\text{AreaA} - \text{AreaB}}{t}$
11. [SC 2002/11 SG] A car is driven at $25 \text{ m}\cdot\text{s}^{-1}$ in a municipal area. When the driver sees a traffic officer at a speed trap, he realises he is travelling too fast. He immediately applies the brakes of the car while still 100 m away from the speed trap.
- Calculate the magnitude of the minimum acceleration which the car must have to avoid exceeding the speed limit, if the municipal speed limit is $16.6 \text{ m}\cdot\text{s}^{-1}$.
 - Calculate the time from the instant the driver applied the brakes until he reaches the speed trap. Assume that the car's velocity, when reaching the trap, is $16.6 \text{ m}\cdot\text{s}^{-1}$.
12. A traffic officer is watching his speed trap equipment at the bottom of a valley. He can see cars as they enter the valley 1 km to his left until they leave the valley 1 km to his right. Nelson is recording the times of cars entering and leaving the valley for a school project. Nelson notices a white Toyota enter the valley at 11:01:30 and leave the valley at 11:02:42. Afterwards, Nelson hears that the traffic officer recorded the Toyota doing $140 \text{ km}\cdot\text{hr}^{-1}$.
- What was the time interval (Δt) for the Toyota to travel through the valley?
 - What was the average speed of the Toyota?
 - Convert this speed to $\text{km}\cdot\text{hr}^{-1}$.
 - Discuss whether the Toyota could have been travelling at $140 \text{ km}\cdot\text{hr}^{-1}$ at the bottom of the valley.
 - Discuss the differences between the instantaneous speed (as measured by the speed trap) and average speed (as measured by Nelson).

13. [IEB 2003/11HG] A velocity-time graph for a ball rolling along a track is shown below. The graph has been divided up into 3 sections, A, B and C for easy reference. (Disregard any effects of friction.)

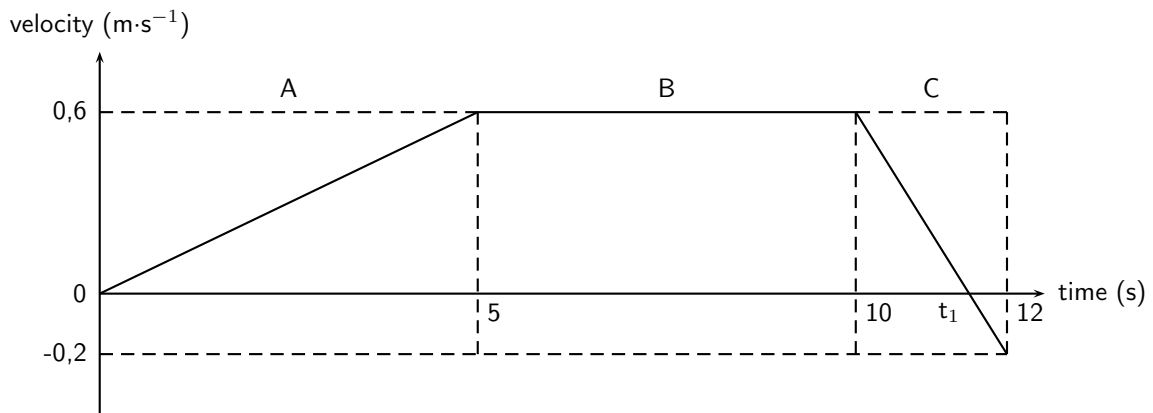

- (a) Use the graph to determine the following:
- the speed 5 s after the start
 - the distance travelled in Section A
 - the acceleration in Section C
- (b) At time t_1 the velocity-time graph intersects the time axis. Use an appropriate equation of motion to calculate the value of time t_1 (in s).
- (c) Sketch a displacement-time graph for the motion of the ball for these 12 s. (You do not need to calculate the actual values of the displacement for each time interval, but do pay attention to the general shape of this graph during each time interval.)
14. In towns and cities, the speed limit is $60 \text{ km}\cdot\text{hr}^{-1}$. The length of the average car is 3.5 m, and the width of the average car is 2 m. In order to cross the road, you need to be able to walk further than the width of a car, before that car reaches you. To cross safely, you should be able to walk at least 2 m further than the width of the car (4 m in total), before the car reaches you.
- If your walking speed is $4 \text{ km}\cdot\text{hr}^{-1}$, what is your walking speed in $\text{m}\cdot\text{s}^{-1}$?
 - How long does it take you to walk a distance equal to the width of the average car?
 - What is the speed in $\text{m}\cdot\text{s}^{-1}$ of a car travelling at the speed limit in a town?
 - How many metres does a car travelling at the speed limit travel, in the same time that it takes you to walk a distance equal to the width of car?
 - Why is the answer to the previous question important?
 - If you see a car driving toward you, and it is 28 m away (the same as the length of 8 cars), is it safe to walk across the road?
 - How far away must a car be, before you think it might be safe to cross? How many car-lengths is this distance?
15. A bus on a straight road starts from rest at a bus stop and accelerates at $2 \text{ m}\cdot\text{s}^{-2}$ until it reaches a speed of $20 \text{ m}\cdot\text{s}^{-1}$. Then the bus travels for 20 s at a constant speed until the driver sees the next bus stop in the distance. The driver applies the brakes, stopping the bus in a uniform manner in 5 s.
- How long does the bus take to travel from the first bus stop to the second bus stop?
 - What is the average velocity of the bus during the trip?

Chapter 4

Gravity and Mechanical Energy - Grade 10

4.1 Weight

Weight is the gravitational force that the Earth exerts on any object. The weight of an object gives you an indication of how strongly the Earth attracts that body towards its centre. Weight is calculated as follows:

$$\text{Weight} = mg$$

where m = mass of the object (in kg)
and g = the acceleration due to gravity ($9,8 \text{ m}\cdot\text{s}^{-2}$)

For example, what is Sarah's weight if her mass is 50 kg. Sarah's weight is calculated according to:

$$\begin{aligned}\text{Weight} &= mg \\ &= (50 \text{ kg})(9,8 \text{ m}\cdot\text{s}^{-2}) \\ &= 490 \text{ kg}\cdot\text{m}\cdot\text{s}^{-2} \\ &= 490 \text{ N}\end{aligned}$$

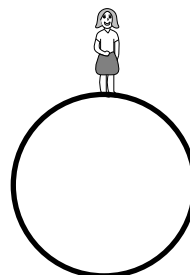

Important: Weight is sometimes abbreviated as F_g which refers to the force of gravity. Do not use the abbreviation 'W' for weight as it refers to 'Work'.

Now, we have said that the value of g is approximately $9,8 \text{ m}\cdot\text{s}^{-2}$ on the surface of the Earth. The actual value varies slightly over the surface of the Earth. Each planet in our Solar System has its own value for g . These values are listed as multiples of g on Earth in Table 4.1



Worked Example 15: Determining mass and weight on other planets

Question: Sarah's mass on Earth is 50 kg. What is her mass and weight on Mars?

Answer

Step 1 : Determine what information is given and what is asked

m (on Earth) = 50 kg

m (on Mars) = ?

Weight (on Mars) = ?

Planet	Gravitational Acceleration (multiples of g on Earth)
Mercury	0.376
Venus	0.903
Earth	1
Mars	0.38
Jupiter	2.34
Saturn	1.16
Uranus	1.15
Neptune	1.19
Pluto	0.066

Table 4.1: A list of the gravitational accelerations at the surfaces of each of the planets in our solar system. Values are listed as multiples of g on Earth. **Note:** The "surface" is taken to mean the cloud tops of the gas giants (Jupiter, Saturn, Uranus and Neptune).

Step 2 : Calculate her mass on Mars

Sarah's mass does not change because she is still made up of the same amount of matter. Her mass on Mars is therefore 50 kg.

Step 3 : Calculate her weight on Mars

$$\begin{aligned} \text{Sarah's weight} &= 50 \times 0,38 \times 9,8 \\ &= 186,2 \text{ N} \end{aligned}$$

4.1.1 Differences between Mass and Weight

Mass is measured in kilograms (kg) and is the amount of matter in an object. An object's mass does not change unless matter is added or removed from the object.

The differences between mass and weight can be summarised in the following table:

Mass	Weight
1. is a measure of how many molecules there are in an object.	1. is the force with which the Earth attracts an object.
2. is measured in kilograms.	2. is measured in newtons
3. is the same on any planet.	3. is different on different planets.
4. is a scalar.	4. is a vector.



Exercise: Weight

- A bag of sugar has a mass of 1 kg. How much does it weigh:
 - on Earth?
 - on Jupiter?
 - on Pluto?
- Neil Armstrong was the first man to walk on the surface of the Moon. The gravitational acceleration on the Moon is $\frac{1}{6}$ of the gravitational acceleration on Earth, and there is no gravitational acceleration in outer space. If Neil's mass was 90 kg, what was his weight:
 - on Earth?

- (b) on the Moon?
 - (c) in outer space?
3. A monkey has a mass of 15 kg on Earth. The monkey travels to Mars. What is his mass and weight on Mars?
 4. Determine your mass by using a bathroom scale and calculate your weight for each planet in the Solar System, using the values given in Table 4.1
-

4.2 Acceleration due to Gravity

4.2.1 Gravitational Fields

A *field* is a region of space in which a mass experiences a force. Therefore, a *gravitational field* is a region of space in which a mass experiences a gravitational force.

4.2.2 Free fall



Important: Free fall is motion in the Earth's gravitational field when no other forces act on the object.

Free fall is the term used to describe a special kind of motion in the Earth's gravitational field. Free fall is motion in the Earth's gravitational field when no other forces act on the object. It is basically an ideal situation, since in reality, there is always some air friction which slows down the motion.

Activity :: Experiment : Acceleration due to Gravity

Aim: Investigating the acceleration of two different objects during free fall.

Apparatus: Tennis ball and a sheet of A4 paper.

Method:

1. Hold the tennis ball and sheet of paper (horizontally) the same distance from the ground. Which one would strike the ground first if both were dropped?

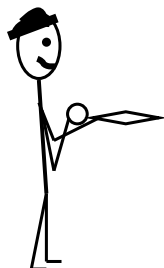

2. Drop both objects and observe. Explain your observations.
3. Now crumple the paper into a ball, more or less the same size as the tennis ball. Drop the paper and tennis ball again and observe. Explain your observations.
4. Why do you think the two situations are different?
5. Compare the value for the acceleration due to gravity of the tennis ball to the crumpled piece of paper.
6. Predict what will happen if an iron ball and a tennis ball of the same size are dropped from the same height. What will the values for their acceleration due to gravity be?

If a metal ball and tennis ball (of the same size) were dropped from the same height, both would reach the ground at the same time. It does not matter that the one ball is heavier than the other. The acceleration of an object due to gravity is independent of the mass of the object. It does not matter what the mass of the object is.

The shape of the object, however, is important. The sheet of paper took much longer to reach the ground than the tennis ball. This is because the effect of air friction on the paper was much greater than the air friction on the tennis ball.

If we lived in a world where there was no air resistance, the A4 sheet of paper and the tennis ball would reach the ground at the same time. This happens in outer space or in a vacuum.

Galileo Galilei, an Italian scientist, studied the motion of objects. The following case study will tell you more about one of his investigations.

Activity :: Case Study : Galileo Galilei

In the late sixteenth century, it was generally believed that heavier objects would fall faster than lighter objects. The Italian scientist Galileo Galilei thought differently. Galileo hypothesized that two objects would fall at the same rate regardless of their mass. Legend has it that in 1590, Galileo planned out an experiment. He climbed to the top of the Leaning Tower of Pisa and dropped several large objects to test his theory. He wanted to show that two different objects fall at the same rate (as long as we ignore air resistance). Galileo's experiment proved his hypothesis correct; the acceleration of a falling object is independent of the object's mass.

A few decades after Galileo, Sir Isaac Newton would show that acceleration depends upon both force and mass. While there is greater force acting on a larger object, this force is canceled out by the object's greater mass. Thus two objects will fall (actually they are pulled) to the earth at exactly the same rate.

Questions: Read the case study above and answer the following questions.

1. Divide into pairs and explain Galileo's experiment to your friend.
 2. Write down an aim and a hypothesis for Galileo's experiment.
 3. Write down the result and conclusion for Galileo's experiment.
-
-

Activity :: Research Project : Experimental Design

Design an experiment similar to the one done by Galileo to prove that the acceleration due to gravity of an object is independent of the object's mass. The investigation must be such that you can perform it at home or at school. Bring your apparatus to school and perform the experiment. Write it up and hand it in for assessment.

Activity :: Case Study : Determining the acceleration due to gravity 1

Study the set of photographs alongside and answer the following questions:

1. Determine the time between each picture if the frequency of the exposures were 10 Hz.
2. Determine the distance between each picture.
3. Calculate the velocity of the ball between pictures 1 and 3.

$$v = \frac{x_3 - x_1}{t_3 - t_1}$$

4. Calculate the velocity of the ball between pictures 4 and 6.
5. Calculate the acceleration the ball between pictures 2 and 5.

$$a = \frac{v_5 - v_2}{t_5 - t_2}$$

6. Compare your answer to the value for the acceleration due to gravity ($9,8 \text{ m}\cdot\text{s}^{-2}$).

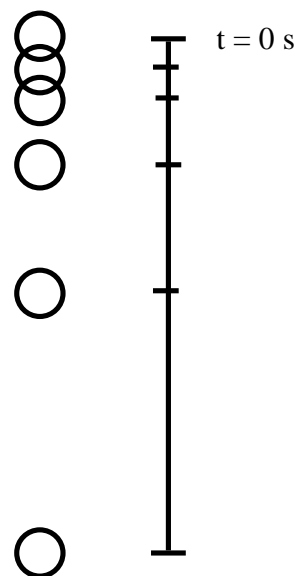

The acceleration due to gravity is constant. This means we can use the equations of motion under constant acceleration that we derived in Chapter 3 (on Page 23) to describe the motion of an object in free fall. The equations are repeated here for ease of use.

v_i = initial velocity ($\text{m}\cdot\text{s}^{-1}$) at $t = 0 \text{ s}$

v_f = final velocity ($\text{m}\cdot\text{s}^{-1}$) at time t

Δx = displacement (m)

t = time (s)

Δt = time interval (s)

g = acceleration ($\text{m}\cdot\text{s}^{-2}$)

$$v_f = v_i + gt \quad (4.1)$$

$$\Delta x = \frac{(v_i + v_f)t}{2} \quad (4.2)$$

$$\Delta x = v_i t + \frac{1}{2}gt^2 \quad (4.3)$$

$$v_f^2 = v_i^2 + 2g\Delta x \quad (4.4)$$

Activity :: Experiment : Determining the acceleration due to gravity 2

Work in groups of at least two people.

Aim: To determine the acceleration of an object in freefall.

Apparatus: Large marble, two stopwatches, measuring tape.

Method:

1. Measure the height of a door, from the top of the door to the floor, exactly. Write down the measurement.
2. One person must hold the marble at the top of the door. Drop the marble to the floor at the same time as he/she starts the first stopwatch.
3. The second person watches the floor and starts his stopwatch when the marble hits the floor.
4. The two stopwatches are stopped together and the two times subtracted. The difference in time will give the time taken for the marble to fall from the top of the door to the floor.
5. Design a table to show the results of your experiment. Choose appropriate headings and units.
6. Choose an appropriate equation of motion to calculate the acceleration of the marble. Remember that the marble starts from rest and that its displacement was determined in the first step.
7. Write a conclusion for your investigation.
8. Answer the following questions:
 - (a) Why do you think two stopwatches were used in this investigation?
 - (b) Compare the value for acceleration obtained in your investigation with the value of acceleration due to gravity ($9,8 \text{ m}\cdot\text{s}^{-2}$). Explain your answer.



Worked Example 16: A freely falling ball

Question: A ball is dropped from the balcony of a tall building. The balcony is 15 m above the ground. Assuming gravitational acceleration is $9,8 \text{ m}\cdot\text{s}^{-2}$, find:

1. the time required for the ball to hit the ground, and
2. the velocity with which it hits the ground.

Answer

Step 1 : Draw a rough sketch of the problem

It always helps to understand the problem if we draw a picture like the one below:

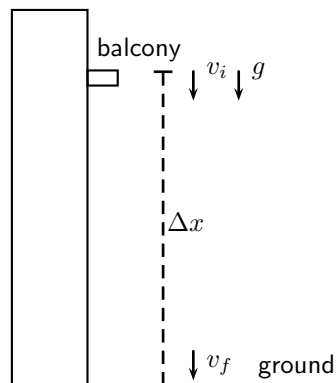

Step 2 : Identify what information is given and what is asked for

We have these quantities:

$$\begin{aligned}\Delta x &= 15 \text{ m} \\ v_i &= 0 \text{ m}\cdot\text{s}^{-1} \\ g &= 9,8 \text{ m}\cdot\text{s}^{-2}\end{aligned}$$

Step 3 : Choose up or down as the positive direction

Since the ball is falling, we choose down as positive. This means that the values for v_i , Δx and a will be positive.

Step 4 : Choose the most appropriate equation.

We can use equation 21.3 to find the time: $\Delta x = v_i t + \frac{1}{2} g t^2$

Step 5 : Use the equation to find t .

$$\begin{aligned}\Delta x &= v_i t + \frac{1}{2} g t^2 \\ 15 &= (0)t + \frac{1}{2}(9,8)(t)^2 \\ 15 &= 4,9 t^2 \\ t^2 &= 3.0612... \\ t &= 1,7496... \\ t &= 1,75 \text{ s}\end{aligned}$$

Step 6 : Find the final velocity v_f .

Using equation 21.1 to find v_f :

$$\begin{aligned}v_f &= v_i + g t \\ v_f &= 0 + (9,8)(1,7496...) \\ v_f &= 17,1464...\end{aligned}$$

Remember to add the direction: $v_f = 17,15 \text{ m}\cdot\text{s}^{-1}$ downwards.

By now you should have seen that free fall motion is just a special case of motion with constant acceleration, and we use the same equations as before. The only difference is that the value for the acceleration, a , is always equal to the value of gravitational acceleration, g . In the equations of motion we can replace a with g .

**Exercise: Gravitational Acceleration**

1. A brick falls from the top of a 5 m high building. Calculate the velocity with which the brick reaches the ground. How long does it take the brick to reach the ground?
2. A stone is dropped from a window. It takes the stone 1,5 seconds to reach the ground. How high above the ground is the window?
3. An apple falls from a tree from a height of 1,8 m. What is the velocity of the apple when it reaches the ground?

4.3 Potential Energy

The potential energy of an object is generally defined as the energy an object has because of its position relative to other objects that it interacts with. There are different kinds of potential energy such as gravitational potential energy, chemical potential energy, electrical potential energy, to name a few. In this section we will be looking at gravitational potential energy.

**Definition: Potential energy**

Potential energy is the energy an object has due to its position or state.

Gravitational potential energy is the energy of an object due to its position above the surface of the Earth. The symbol PE is used to refer to gravitational potential energy. You will often find that the words potential energy are used where *gravitational* potential energy is meant. We can define potential energy (or gravitational potential energy, if you like) as:

$$PE = mgh \quad (4.5)$$

where PE = potential energy measured in joules (J)

m = mass of the object (measured in kg)

g = gravitational acceleration ($9,8 \text{ m}\cdot\text{s}^{-2}$)

h = perpendicular height from the reference point (measured in m)

A suitcase, with a mass of 1 kg, is placed at the top of a 2 m high cupboard. By lifting the suitcase against the force of gravity, we give the suitcase potential energy. This potential energy can be calculated using equation 4.5.

If the suitcase falls off the cupboard, it will lose its potential energy. Halfway down the cupboard, the suitcase will have lost half its potential energy and will have only 9,8 J left. At the bottom of the cupboard the suitcase will have lost all its potential energy and its potential energy will be equal to zero.

Objects have maximum potential energy at a maximum height and will lose their potential energy as they fall.

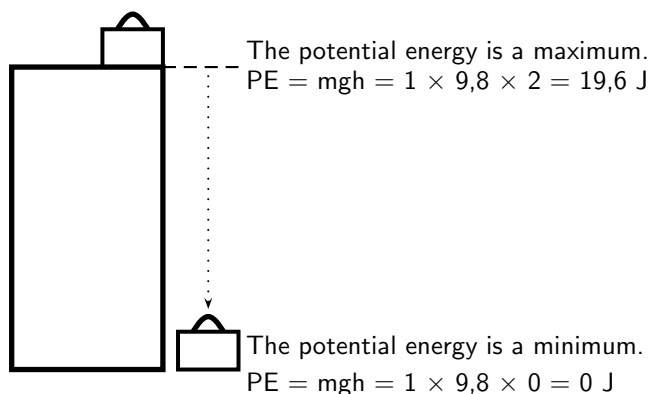
**Worked Example 17: Gravitational potential energy**

Question: A brick with a mass of 1 kg is lifted to the top of a 4 m high roof. It slips off the roof and falls to the ground. Calculate the potential energy of the brick at the top of the roof and on the ground once it has fallen.

Answer

Step 1 : Analyse the question to determine what information is provided

- The mass of the brick is $m = 1 \text{ kg}$
- The height lifted is $h = 4 \text{ m}$

All quantities are in SI units.

Step 2 : Analyse the question to determine what is being asked

- We are asked to find the gain in potential energy of the brick as it is lifted onto the roof.

- We also need to calculate the potential energy once the brick is on the ground again.

Step 3 : Identify the type of potential energy involved

Since the block is being lifted we are dealing with gravitational potential energy. To work out PE , we need to know the mass of the object and the height lifted. As both of these are given, we just substitute them into the equation for PE .

Step 4 : Substitute and calculate

$$\begin{aligned} PE &= mgh \\ &= (1)(9,8)(4) \\ &= 39,2 \text{ J} \end{aligned}$$



Exercise: Gravitational Potential Energy

- Describe the relationship between an object's gravitational potential energy and its:
 - mass and
 - height above a reference point.
- A boy, of mass 30 kg, climbs onto the roof of their garage. The roof is 2,5 m from the ground. He now jumps off the roof and lands on the ground.
 - How much potential energy has the boy gained by climbing on the roof?
 - The boy now jumps down. What is the potential energy of the boy when he is 1 m from the ground?
 - What is the potential energy of the boy when he lands on the ground?
- A hiker walks up a mountain, 800 m above sea level, to spend the night at the top in the first overnight hut. The second day he walks to the second overnight hut, 500 m above sea level. The third day he returns to his starting point, 200 m above sea level.
 - What is the potential energy of the hiker at the first hut (relative to sea level)?
 - How much potential energy has the hiker lost during the second day?
 - How much potential energy did the hiker have when he started his journey (relative to sea level)?
 - How much potential energy did the hiker have at the end of his journey?

4.4 Kinetic Energy



Definition: Kinetic Energy

Kinetic energy is the energy an object has due to its motion.

Kinetic energy is the energy an object has because of its motion. This means that any moving object has kinetic energy. The faster it moves, the more kinetic energy it has. Kinetic energy (KE) is therefore dependent on the velocity of the object. The mass of the object also plays a

role. A truck of 2000 kg, moving at $100 \text{ km}\cdot\text{hr}^{-1}$, will have more kinetic energy than a car of 500 kg, also moving at $100 \text{ km}\cdot\text{hr}^{-1}$. Kinetic energy is defined as:

$$KE = \frac{1}{2}mv^2 \quad (4.6)$$

Consider the 1 kg suitcase on the cupboard that was discussed earlier. When the suitcase falls, it will gain velocity (fall faster), until it reaches the ground with a maximum velocity. The suitcase will not have any kinetic energy when it is on top of the cupboard because it is not moving. Once it starts to fall it will gain kinetic energy, because it gains velocity. Its kinetic energy will increase until it is a maximum when the suitcase reaches the ground.

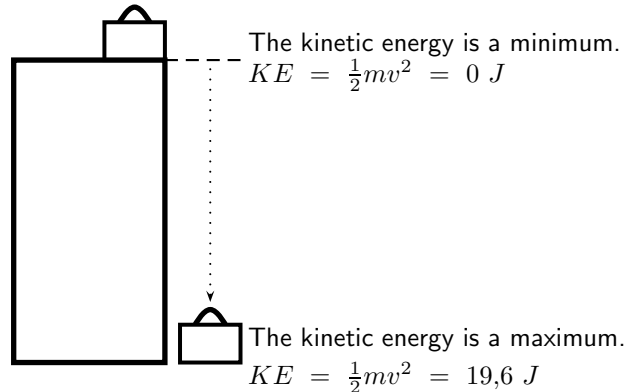

Worked Example 18: Calculation of Kinetic Energy

Question: A 1 kg brick falls off a 4 m high roof. It reaches the ground with a velocity of $8,85 \text{ m}\cdot\text{s}^{-1}$. What is the kinetic energy of the brick when it starts to fall and when it reaches the ground?

Answer

Step 1 : Analyse the question to determine what information is provided

- The mass of the rock $m = 1 \text{ kg}$
- The velocity of the rock at the bottom $v_{bottom} = 8,85 \text{ m}\cdot\text{s}^{-1}$

These are both in the correct units so we do not have to worry about unit conversions.

Step 2 : Analyse the question to determine what is being asked

We are asked to find the kinetic energy of the brick at the top and the bottom. From the definition we know that to work out KE , we need to know the mass and the velocity of the object and we are given both of these values.

Step 3 : Calculate the kinetic energy at the top

Since the brick is not moving at the top, its kinetic energy is zero.

Step 4 : Substitute and calculate the kinetic energy

$$\begin{aligned} KE &= \frac{1}{2}mv^2 \\ &= \frac{1}{2}(1 \text{ kg})(8,85 \text{ m}\cdot\text{s}^{-1})^2 \\ &= 39,2 \text{ J} \end{aligned}$$

4.4.1 Checking units

According to the equation for kinetic energy, the unit should be $\text{kg} \cdot \text{m}^2 \cdot \text{s}^{-2}$. We can prove that this unit is equal to the joule, the unit for energy.

$$\begin{aligned} (\text{kg})(\text{m} \cdot \text{s}^{-1})^2 &= (\text{kg} \cdot \text{m} \cdot \text{s}^{-2}) \cdot \text{m} \\ &= \text{N} \cdot \text{m} \quad (\text{because Force (N)} = \text{mass (kg)} \times \text{acceleration (m} \cdot \text{s}^{-2}\text{)}) \\ &= \text{J} \quad (\text{Work (J)} = \text{Force (N)} \times \text{distance (m)}) \end{aligned}$$

We can do the same to prove that the unit for potential energy is equal to the joule:

$$\begin{aligned} (\text{kg})(\text{m} \cdot \text{s}^{-2})(\text{m}) &= \text{N} \cdot \text{m} \\ &= \text{J} \end{aligned}$$



Worked Example 19: Mixing Units & Energy Calculations

Question: A bullet, having a mass of 150 g, is shot with a muzzle velocity of $960 \text{ m} \cdot \text{s}^{-1}$. Calculate its kinetic energy?

Answer

Step 1 : Analyse the question to determine what information is provided

- We are given the mass of the bullet $m = 150 \text{ g}$. This is not the unit we want mass to be in. We need to convert to kg.

$$\begin{aligned} \text{Mass in grams} \div 1000 &= \text{Mass in kg} \\ 150 \text{ g} \div 1000 &= 0,150 \text{ kg} \end{aligned}$$

- We are given the initial velocity with which the bullet leaves the barrel, called the muzzle velocity, and it is $v = 960 \text{ m} \cdot \text{s}^{-1}$.

Step 2 : Analyse the question to determine what is being asked

- We are asked to find the kinetic energy.

Step 3 : Substitute and calculate

We just substitute the mass and velocity (which are known) into the equation for kinetic energy:

$$\begin{aligned} KE &= \frac{1}{2}mv^2 \\ &= \frac{1}{2}(150)(960)^2 \\ &= 69\,120 \text{ J} \end{aligned}$$



Exercise: Kinetic Energy

- Describe the relationship between an object's kinetic energy and its:
 - mass and
 - velocity
- A stone with a mass of 100 g is thrown up into the air. It has an initial velocity of $3 \text{ m} \cdot \text{s}^{-1}$. Calculate its kinetic energy
 - as it leaves the thrower's hand.
 - when it reaches its turning point.

3. A car with a mass of 700 kg is travelling at a constant velocity of $100 \text{ km}\cdot\text{hr}^{-1}$. Calculate the kinetic energy of the car.
-

4.5 Mechanical Energy



Important: Mechanical energy is the sum of the gravitational potential energy and the kinetic energy.

Mechanical energy, U , is simply the sum of gravitational potential energy (PE) and the kinetic energy (KE). Mechanical energy is defined as:

$$U = PE + KE \quad (4.7)$$

$$\begin{aligned} U &= PE + KE \\ U &= mgh + \frac{1}{2}mv^2 \end{aligned} \quad (4.8)$$

4.5.1 Conservation of Mechanical Energy

The Law of Conservation of Energy states:

Energy cannot be created or destroyed, but is merely changed from one form into another.



Definition: Conservation of Energy

The Law of Conservation of Energy: Energy cannot be created or destroyed, but is merely changed from one form into another.

So far we have looked at two types of energy: gravitational potential energy and kinetic energy. The sum of the gravitational potential energy and kinetic energy is called the mechanical energy. In a closed system, one where there are no external forces acting, the mechanical energy will remain constant. In other words, it will not change (become more or less). This is called the Law of Conservation of Mechanical Energy and it states:

The total amount of mechanical energy in a closed system remains constant.



Definition: Conservation of Mechanical Energy

Law of Conservation of Mechanical Energy: The total amount of mechanical energy in a closed system remains constant.

This means that potential energy can become kinetic energy, or vice versa, but energy cannot 'disappear'. The mechanical energy of an object moving in the Earth's gravitational field (or accelerating as a result of gravity) is constant or conserved, unless external forces, like air resistance, acts on the object.

We can now use the conservation of mechanical energy to calculate the velocity of a body in freefall and show that the velocity is independent of mass.

Important: In problems involving the use of conservation of energy, the path taken by the object can be ignored. The only important quantities are the object's velocity (which gives its kinetic energy) and height above the reference point (which gives its gravitational potential energy).

Important: In the absence of friction, mechanical energy is conserved and

$$U_{\text{before}} = U_{\text{after}}$$

In the presence of friction, mechanical energy is **not** conserved. The mechanical energy lost is equal to the work done against friction.

$$\Delta U = U_{\text{before}} - U_{\text{after}} = \text{work done against friction}$$

In general mechanical energy is conserved in the absence of external forces. Examples of external forces are: applied forces, frictional forces, air resistance, tension, normal forces.

In the presence of internal forces like the force due to gravity or the force in a spring, mechanical energy is conserved.

4.5.2 Using the Law of Conservation of Energy

Mechanical energy is conserved (in the absence of friction). Therefore we can say that the sum of the PE and the KE anywhere during the motion must be equal to the sum of the PE and the KE anywhere else in the motion.

We can now apply this to the example of the suitcase on the cupboard. Consider the mechanical energy of the suitcase at the top and at the bottom. We can say:

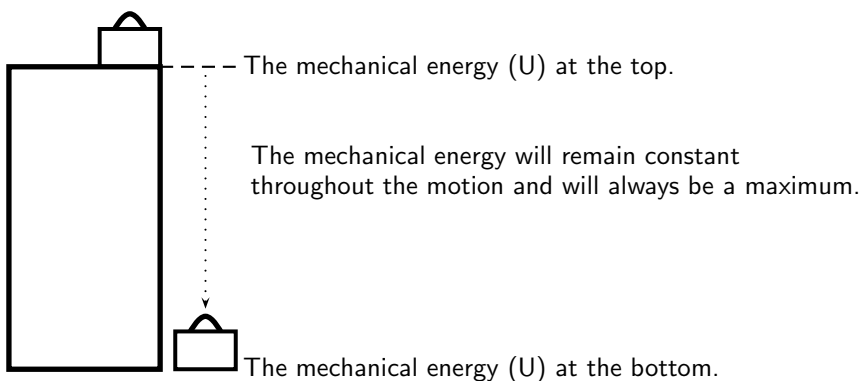

$$\begin{aligned}
 U_{\text{top}} &= U_{\text{bottom}} \\
 PE_{\text{top}} + KE_{\text{top}} &= PE_{\text{bottom}} + KE_{\text{bottom}} \\
 mgh + \frac{1}{2}mv^2 &= mgh + \frac{1}{2}mv^2 \\
 (1)(9,8)(2) + 0 &= 0 + \frac{1}{2}(1)(v^2) \\
 19,6 \text{ J} &= \frac{1}{2}v^2 \\
 39,2 &= v^2 \\
 v &= 6,26 \text{ m} \cdot \text{s}^{-1}
 \end{aligned}$$

The suitcase will strike the ground with a velocity of $6,26 \text{ m}\cdot\text{s}^{-1}$.

From this we see that when an object is lifted, like the suitcase in our example, it gains potential energy. As it falls back to the ground, it will lose this potential energy, but gain kinetic energy. We know that energy cannot be created or destroyed, but only changed from one form into another. In our example, the potential energy that the suitcase loses is changed to kinetic energy.

The suitcase will have maximum potential energy at the top of the cupboard and maximum kinetic energy at the bottom of the cupboard. Halfway down it will have half kinetic energy and half potential energy. As it moves down, the potential energy will be converted (changed) into kinetic energy until all the potential energy is gone and only kinetic energy is left. The $19,6 \text{ J}$ of potential energy at the top will become $19,6 \text{ J}$ of kinetic energy at the bottom.



Worked Example 20: Using the Law of Conservation of Mechanical Energy

Question: During a flood a tree trunk of mass 100 kg falls down a waterfall. The waterfall is 5 m high. If air resistance is ignored, calculate

1. the potential energy of the tree trunk at the top of the waterfall.
2. the kinetic energy of the tree trunk at the bottom of the waterfall.
3. the magnitude of the velocity of the tree trunk at the bottom of the waterfall.

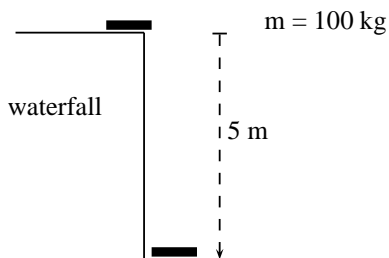

Answer

Step 1 : Analyse the question to determine what information is provided

- The mass of the tree trunk $m = 100 \text{ kg}$
- The height of the waterfall $h = 5 \text{ m}$.
These are all in SI units so we do not have to convert.

Step 2 : Analyse the question to determine what is being asked

- Potential energy at the top
- Kinetic energy at the bottom
- Velocity at the bottom

Step 3 : Calculate the potential energy.

$$\begin{aligned} PE &= mgh \\ PE &= (100)(9,8)(5) \\ PE &= 4900 \text{ J} \end{aligned}$$

Step 4 : Calculate the kinetic energy.

The kinetic energy of the tree trunk at the bottom of the waterfall is equal to the potential energy it had at the top of the waterfall. Therefore $KE = 4900 \text{ J}$.

Step 5 : Calculate the velocity.

To calculate the velocity of the tree trunk we need to use the equation for kinetic energy.

$$\begin{aligned} KE &= \frac{1}{2}mv^2 \\ 4900 &= \frac{1}{2}(100)(v^2) \\ 98 &= v^2 \\ v &= 9,899... \\ v &= 9,90 \text{ m} \cdot \text{s}^{-1} \text{ downwards} \end{aligned}$$



Worked Example 21: Pendulum

Question: A 2 kg metal ball is suspended from a rope. If it is released from point *A* and swings down to the point *B* (the bottom of its arc):

1. Show that the velocity of the ball is independent of its mass.
2. Calculate the velocity of the ball at point *B*.

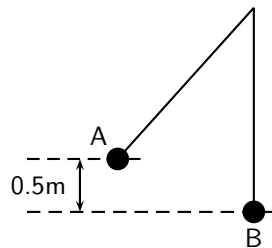

Answer

Step 1 : Analyse the question to determine what information is provided

- The mass of the metal ball is $m = 2 \text{ kg}$
- The change in height going from point *A* to point *B* is $h = 0,5 \text{ m}$
- The ball is released from point *A* so the velocity at point, $v_A = 0 \text{ m} \cdot \text{s}^{-1}$.

All quantities are in SI units.

Step 2 : Analyse the question to determine what is being asked

- Prove that the velocity is independent of mass.
- Find the velocity of the metal ball at point *B*.

Step 3 : Apply the Law of Conservation of Mechanical Energy to the situation

As there is no friction, mechanical energy is conserved. Therefore:

$$\begin{aligned} U_A &= U_B \\ PE_A + KE_A &= PE_B + KE_B \\ mgh_A + \frac{1}{2}m(v_A)^2 &= mgh_B + \frac{1}{2}m(v_B)^2 \\ mgh_A + 0 &= 0 + \frac{1}{2}m(v_B)^2 \\ mgh_A &= \frac{1}{2}m(v_B)^2 \end{aligned}$$

As the mass of the ball m appears on both sides of the equation, it can be eliminated so that the equation becomes:

$$gh_A = \frac{1}{2}(v_B)^2$$

$$2gh_A = (v_B)^2$$

This proves that the velocity of the ball is independent of its mass. It does not matter what its mass is, it will always have the same velocity when it falls through this height.

Step 4 : Calculate the velocity of the ball

We can use the equation above, or do the calculation from 'first principles':

$$\begin{aligned}(v_B)^2 &= 2gh_A \\(v_B)^2 &= (2)(9.8)(0,5) \\(v_B)^2 &= 9,8 \\v_B &= \sqrt{9,8} \text{ m} \cdot \text{s}^{-1}\end{aligned}$$



Exercise: Potential Energy

- A tennis ball, of mass 120 g, is dropped from a height of 5 m. Ignore air friction.
 - What is the potential energy of the ball when it has fallen 3 m?
 - What is the velocity of the ball when it hits the ground?
- A bullet, mass 50 g, is shot vertically up in the air with a muzzle velocity of 200 m·s⁻¹. Use the Principle of Conservation of Mechanical Energy to determine the height that the bullet will reach. Ignore air friction.
- A skier, mass 50 kg, is at the top of a 6,4 m ski slope.
 - Determine the maximum velocity that she can reach when she skies to the bottom of the slope.
 - Do you think that she will reach this velocity? Why/Why not?
- A pendulum bob of mass 1,5 kg, swings from a height A to the bottom of its arc at B. The velocity of the bob at B is 4 m·s⁻¹. Calculate the height A from which the bob was released. Ignore the effects of air friction.
- Prove that the velocity of an object, in free fall, in a closed system, is independent of its mass.

4.6 Energy graphs

Let us consider our example of the suitcase on the cupboard, once more.

Let's look at each of these quantities and draw a graph for each. We will look at how each quantity changes as the suitcase falls from the top to the bottom of the cupboard.

- Potential energy:** The potential energy starts off at a maximum and decreases until it reaches zero at the bottom of the cupboard. It had fallen a distance of 2 metres.

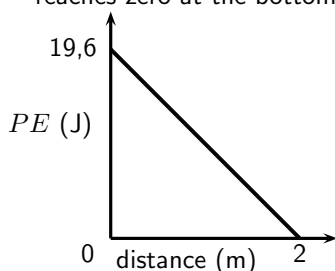

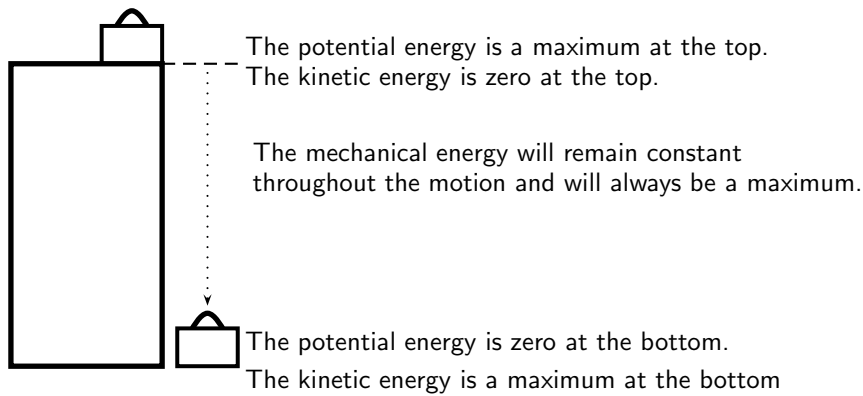

- **Kinetic energy:** The kinetic energy is zero at the start of the fall. When the suitcase reaches the ground, the kinetic energy is a maximum. We also use distance on the x -axis.

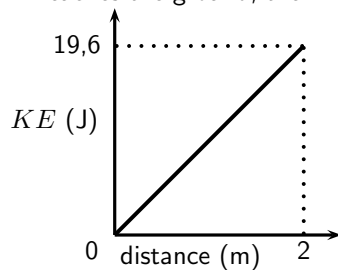

- **Mechanical energy:** The mechanical energy is constant throughout the motion and is always a maximum. At any point in time, when we add the potential energy and the kinetic energy, we will get the same number.

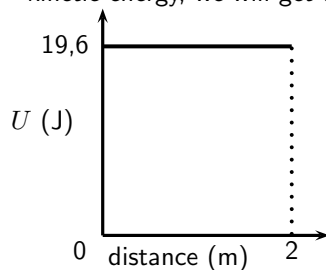

4.7 Summary

- Mass is the amount of matter an object is made up of.
- Weight is the force with which the Earth attracts a body towards its centre.
- A body is in free fall if it is moving in the Earth's gravitational field and no other forces act on it.
- The equations of motion can be used for free fall problems. The acceleration (a) is equal to the acceleration due to gravity (g).
- The potential energy of an object is the energy the object has due to his position above a reference point.
- The kinetic energy of an object is the energy the object has due to its motion.
- Mechanical energy of an object is the sum of the potential energy and kinetic energy of the object.
- The unit for energy is the joule (J).

- The Law of Conservation of Energy states that energy cannot be created or destroyed, but can only be changed from one form into another.
- The Law of Conservation of Mechanical Energy states that the total mechanical energy of an isolated system remains constant.
- The table below summarises the most important equations:

Weight	$F_g = m \cdot g$
Equation of motion	$v_f = v_i + gt$
Equation of motion	$\Delta x = \frac{(v_i + v_f)}{2}t$
Equation of motion	$\Delta x = v_i t + \frac{1}{2}gt^2$
Equation of motion	$v_f^2 = v_i^2 + 2g\Delta x$
Potential Energy	$PE = mgh$
Kinetic Energy	$KE = \frac{1}{2}mv^2$
Mechanical Energy	$U = KE + PE$

4.8 End of Chapter Exercises: Gravity and Mechanical Energy

1. Give one word/term for the following descriptions.
 - (a) The force with which the Earth attracts a body.
 - (b) The unit for energy.
 - (c) The movement of a body in the Earth's gravitational field when no other forces act on it.
 - (d) The sum of the potential and kinetic energy of a body.
 - (e) The amount of matter an object is made up of.
2. Consider the situation where an apple falls from a tree. Indicate whether the following statements regarding this situation are TRUE or FALSE. Write only 'true' or 'false'. If the statement is false, write down the correct statement.
 - (a) The potential energy of the apple is a maximum when the apple lands on the ground.
 - (b) The kinetic energy remains constant throughout the motion.
 - (c) To calculate the potential energy of the apple we need the mass of the apple and the height of the tree.
 - (d) The mechanical energy is a maximum only at the beginning of the motion.
 - (e) The apple falls at an acceleration of $9,8 \text{ m}\cdot\text{s}^{-2}$.
3. [IEB 2005/11 HG] Consider a ball dropped from a height of 1 m on Earth and an identical ball dropped from 1 m on the Moon. Assume both balls fall freely. The acceleration due to gravity on the Moon is one sixth that on Earth. In what way do the following compare when the ball is dropped on Earth and on the Moon.

	Mass	Weight	Increase in kinetic energy
(a)	the same	the same	the same
(b)	the same	greater on Earth	greater on Earth
(c)	the same	greater on Earth	the same
(d)	greater on Earth	greater on Earth	greater on Earth

4. A man fires a rock out of a slingshot directly upward. The rock has an initial velocity of $15 \text{ m}\cdot\text{s}^{-1}$.
 - (a) How long will it take for the rock to reach its highest point?
 - (b) What is the maximum height that the rock will reach?
 - (c) Draw graphs to show how the potential energy, kinetic energy and mechanical energy of the rock changes as it moves to its highest point.

-
5. A metal ball of mass 200 g is tied to a light string to make a pendulum. The ball is pulled to the side to a height (A), 10 cm above the lowest point of the swing (B). Air friction and the mass of the string can be ignored. The ball is let go to swing freely.
- Calculate the potential energy of the ball at point A.
 - Calculate the kinetic energy of the ball at point B.
 - What is the maximum velocity that the ball will reach during its motion?
6. A truck of mass 1,2 tons is parked at the top of a hill, 150 m high. The truck driver lets the truck run freely down the hill to the bottom.
- What is the maximum velocity that the truck can achieve at the bottom of the hill?
 - Will the truck achieve this velocity? Why/why not?
7. A stone is dropped from a window, 3 metres above the ground. The mass of the stone is 25 grams.
- Use the Equations of Motion to calculate the velocity of the stone as it reaches the ground.
 - Use the Principle of Conservation of Energy to prove that your answer in (a) is correct.

Chapter 5

Transverse Pulses - Grade 10

5.1 Introduction

This chapter forms the basis of the discussion into mechanical waves. Waves are all around us, even though most of us are not aware of it. The most common waves are waves in the sea, but waves can be created in any container of water, ranging from an ocean to a tea-cup. Simply, a wave is moving energy.

5.2 What is a medium?

In this chapter, as well as in the following chapters, we will speak about waves moving in a medium. A medium is just the substance or material through which waves move. In other words the medium carries the wave from one place to another. The medium does not create the wave and the medium is not the wave. Air is a medium for sound waves, water is a medium for water waves and rock is a medium for earthquakes (which are also a type of wave). Air, water and rock are therefore examples of media (media is the plural of medium).



Definition: Medium

A medium is the substance or material in which a wave will move.

In each medium, the atoms that make up the medium are moved *temporarily* from their rest position. In order for a wave to travel, the different parts of the medium must be able to interact with each other.

5.3 What is a pulse?

Activity :: Investigation : Observation of Pulses

Take a heavy rope. Have two people hold the rope stretched out horizontally. Flick the rope at one end only once.

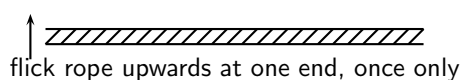

What happens to the disturbance that you created in the rope? Does it stay at the place where it was created or does it move down the length of the rope?

In the activity, we created a *pulse*. A pulse is a *single* disturbance that moves through a medium. A transverse pulse moves perpendicular to the medium. Figure 5.1 shows an example of a transverse pulse. In the activity, the rope or spring was held horizontally and the pulse moved the rope up and down. This was an example of a transverse pulse.



Definition: Pulse

A pulse is a single disturbance that moves through a medium.

5.3.1 Pulse Length and Amplitude

The amplitude of a pulse is a measurement of how far the medium is displaced from a position of rest. The pulse length is a measurement of how long the pulse is. Both these quantities are shown in Figure 5.1.



Definition: Amplitude

The amplitude of a pulse is a measurement of how far the medium is displaced from rest.

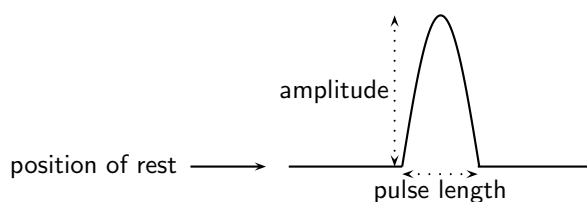
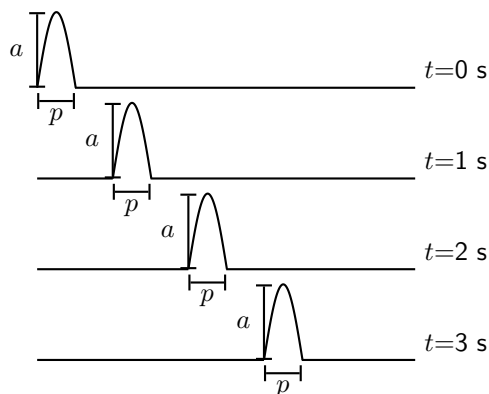

Figure 5.1: Example of a transverse pulse

Activity :: Investigation : Pulse Length and Amplitude

The graphs below show the positions of a pulse at different times.



Use your ruler to measure the lengths of a and p . Fill your answers in the table.

Time	a	p
$t = 0$ s		
$t = 1$ s		
$t = 2$ s		
$t = 3$ s		

What do you notice about the values of a and p ?

In the activity, we found that the values for how high the pulse (a) is and how wide the pulse (p) is the same at different times. *Pulse length* and *amplitude* are two important quantities of a pulse.

5.3.2 Pulse Speed



Definition: Pulse Speed

Pulse speed is the distance a pulse travels in a specific time.

In Chapter 3 we saw that speed was defined as the distance travelled in a specified time. We can use the same definition of speed to calculate how fast a pulse travels. If the pulse travels a distance d in a time t , then the pulse speed v is:

$$v = \frac{d}{t}$$



Worked Example 22: Pulse Speed

Question: A pulse covers a distance of 2 m in 4 s on a heavy rope. Calculate the pulse speed.

Answer

Step 5 : Determine what is given and what is required

We are given:

- the distance travelled by the pulse: $d = 2$ m
- the time taken to travel 2 m: $t = 4$ s

We are required to calculate the speed of the pulse.

Step 6 : Determine how to approach the problem

We can use:

$$v = \frac{d}{t}$$

to calculate the speed of the pulse.

Step 7 : Calculate the pulse speed

$$\begin{aligned} v &= \frac{d}{t} \\ &= \frac{2 \text{ m}}{4 \text{ s}} \\ &= 0,5 \text{ m} \cdot \text{s}^{-1} \end{aligned}$$

Step 8 : Write the final answer

The pulse speed is $0,5 \text{ m} \cdot \text{s}^{-1}$.



Important: The pulse speed depends on the properties of the medium and not on the amplitude or pulse length of the pulse.



Exercise: Pulse Speed

1. A pulse covers a distance of 5 m in 15 seconds. Calculate the speed of the pulse.
2. A pulse has a speed of $5 \text{ cm}\cdot\text{s}^{-1}$. How far does it travel in 2,5 seconds?
3. A pulse has a speed of $0,5 \text{ m}\cdot\text{s}^{-1}$. How long does it take to cover a distance of 25 cm?
4. How long will it take a pulse moving at $0,25 \text{ m}\cdot\text{s}^{-1}$ to travel a distance of 20 m?

5. Examine the two pulses below and state which has the higher speed. Explain your answer.

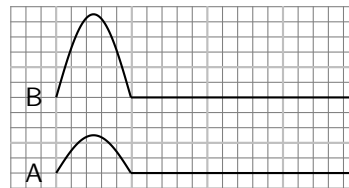

6. Ocean waves do not bring more water onto the shore until the beach is completely submerged. Explain why this is so.

5.4 Graphs of Position and Velocity

When a pulse moves through a medium, there are two different motions: the motion of the particles of the medium and the motion of the pulse. These two motions are at right angles to each other when the pulse is transverse. Each motion will be discussed.

Consider the situation shown in Figure ???. The dot represents one particle of the medium. We see that as the pulse moves to the right the particle only moves up and down.

5.4.1 Motion of a Particle of the Medium

First we consider the motion of a particle of the medium when a pulse moves through the medium. For the explanation we will zoom into the medium so that we are looking at the atoms of the medium. These atoms are connected to each other as shown in Figure 5.2.



Figure 5.2: Particles in a medium.

When a pulse moves through the medium, the particles in the medium **only** move up and down. We can see this in the figure below which shows the motion of a single particle as a pulse moves through the medium.

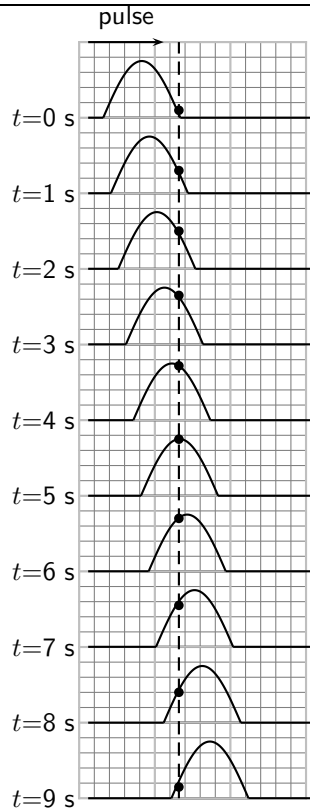

Important: A particle in the medium **only** moves up and down when a transverse pulse moves through the medium. The pulse moves from left to right (or right to left). The motion of the particle is perpendicular to the motion of a transverse pulse.

If you consider the motion of the particle as a function of time, you can draw a graph of position vs. time and velocity vs. time.

Activity :: Investigation : Drawing a position-time graph

1. Study Figure ?? and complete the following table:

time (s)	0	1	2	3	4	5	6	7	8	9
position (cm)										

2. Use your table to draw a graph of position vs. time for a particle in a medium.

The position vs. time graph for a particle in a medium when a pulse passes through the medium is shown in Figure 5.3

Activity :: Investigation : Drawing a velocity-time graph

1. Study Figure 5.3 and Figure 5.4 and complete the following table:

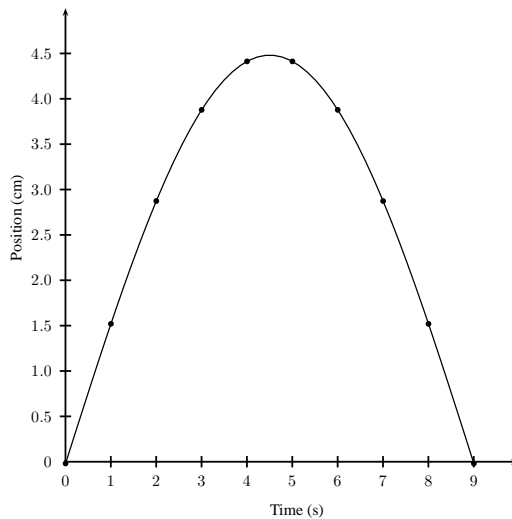

Figure 5.3: Position against Time graph of a particle in the medium through which a transverse pulse is travelling.

time (s)	0	1	2	3	4	5	6	7	8	9
velocity (cm.s ⁻¹)										

2. Use your table to draw a graph of velocity vs time for a particle in a medium.

The velocity vs. time graph for a particle in a medium when a pulse passes through the medium is shown in Figure 5.4.

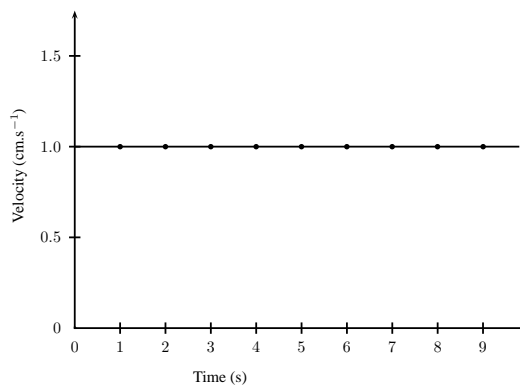

Figure 5.4: Velocity against Time graph of a particle in the medium through which a transverse pulse is travelling.

5.4.2 Motion of the Pulse

The motion of the pulse is much simpler than the motion of a particle in the medium.



Important: A point on a transverse pulse, eg. the peak, **only** moves in the direction of the motion of the pulse.



Worked Example 23: Transverse pulse through a medium

Question:

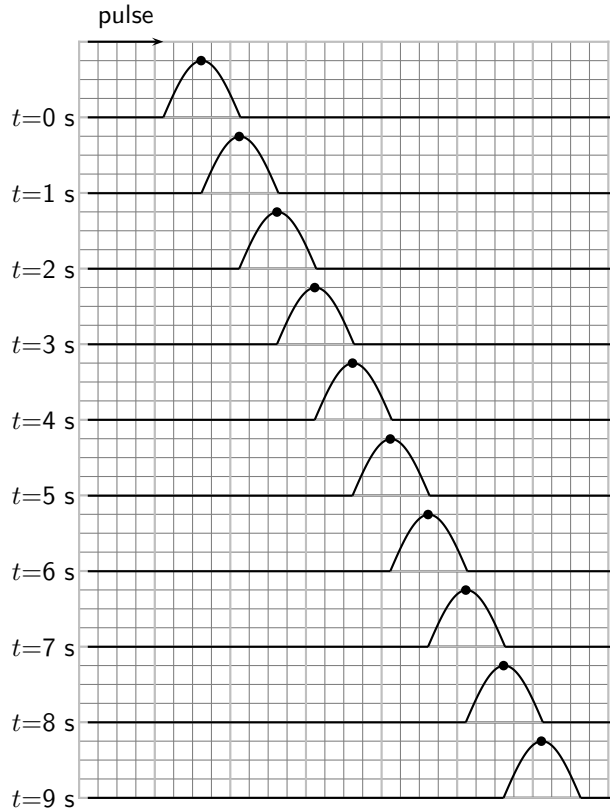

Figure 5.5: Position of the peak of a pulse at different times (since we know the shape of the pulse does not change we can look at only one point on the pulse to keep track of its position, the peak for example). The pulse moves to the right as shown by the arrow.

Given the series of snapshots of a transverse pulse moving through a medium, depicted in Figure 5.5, do the following:

- draw up a table of time, position and velocity,
- plot a position vs. time graph,
- plot a velocity vs. time graph.

Answer

Step 1 : Interpreting the figure

Figure 5.5 shows the motion of a pulse through a medium and a dot to indicate the same position on the pulse. If we follow the dot, we can draw a graph of position vs time for a pulse. At $t = 0$ s the dot is at 0cm. At $t = 1$ s the dot is 1 cm away from its original position. At $t = 2$ s the dot is 2 cm away from its original position, and so on.

Step 2 : We can draw the following table:

time (s)	0	1	2	3	4	5	6	7	8	9
position (cm)										
velocity ($\text{cm}\cdot\text{s}^{-1}$)										

Step 3 : A graph of position vs time is drawn as is shown in the figure.

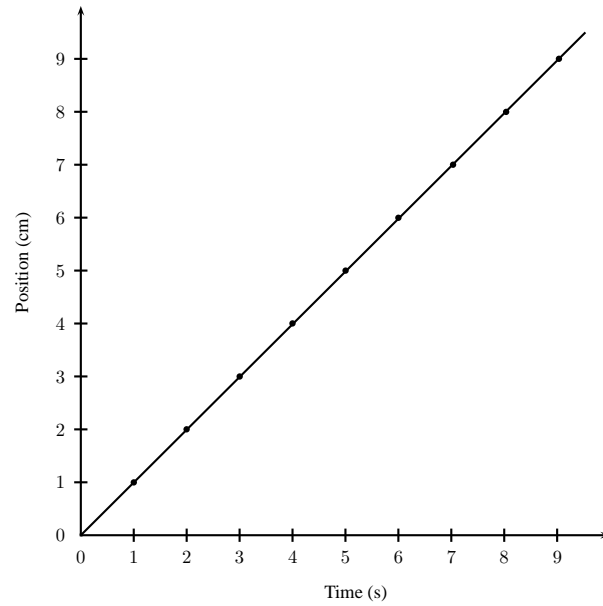

Step 4 : Similarly, a graph of velocity vs time is drawn and is shown in the figure below.

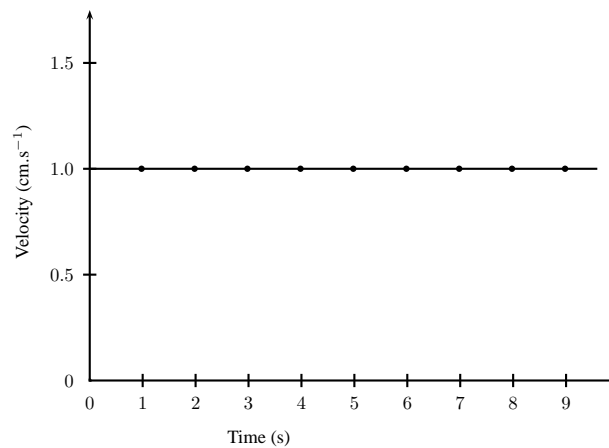

Exercise: Travelling Pulse

1. A pulse is passed through a rope and the following pictures were obtained for each time interval:

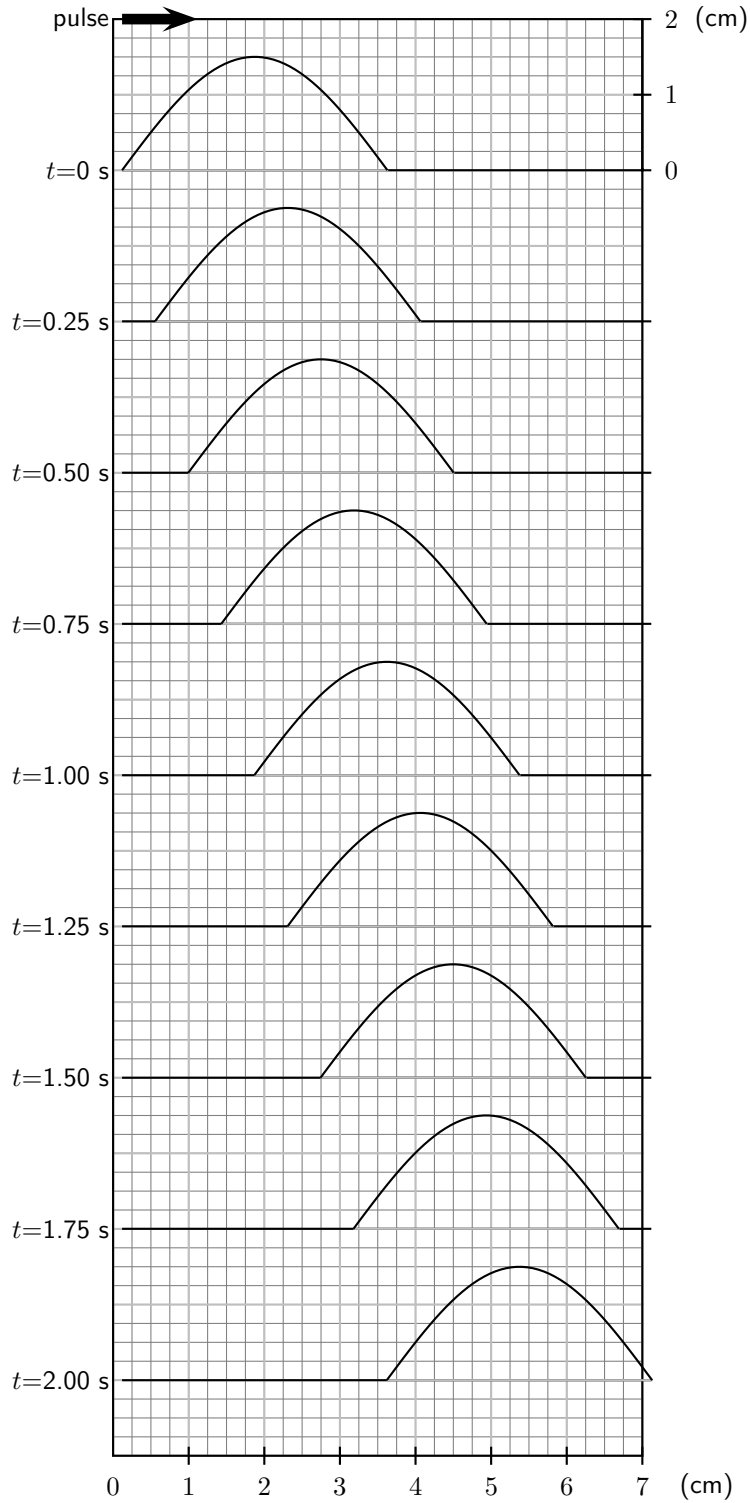

(a) Complete the following table for a particle in the medium:

time (s)	0,00	0,25	0,50	0,75	1,00	1,25	1,50	1,75	2,00
position (mm)									
velocity ($\text{mm}\cdot\text{s}^{-1}$)									

- (b) Draw a position vs. time graph for the motion of a particle in the medium.
- (c) Draw a velocity vs. time graph for the motion of a particle in the medium.
- (d) Draw a position vs. time graph for the motion of the pulse through the rope.
- (e) Draw a velocity vs. time graph for the motion of the pulse through the rope.

5.5 Transmission and Reflection of a Pulse at a Boundary

What happens when a pulse travelling in one medium finds that medium is joined to another?

Activity :: Investigation : Two ropes

Find two different ropes and tie both ropes together. Hold the joined ropes horizontally and create a pulse by flicking the rope up and down. What happens to the pulse when it encounters the join?

When a pulse meets a boundary between two media, part of the pulse is reflected and part of it is transmitted. You will see that in the thin rope the pulse moves back (is reflected). The pulse is also passed on (transmitted) to the thick rope and it moves away from the boundary.

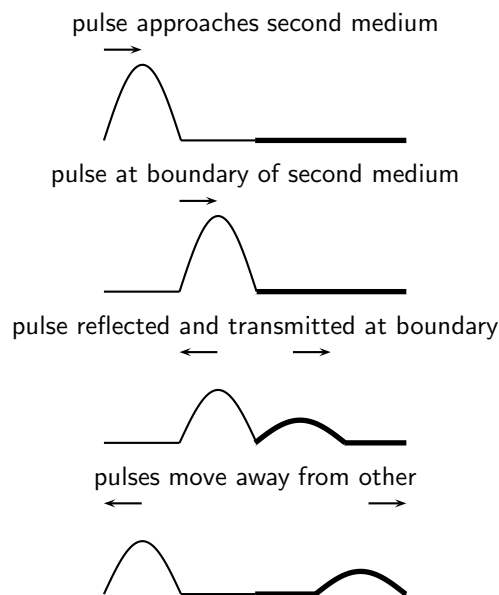

Figure 5.6: Reflection and transmission of a pulse at the boundary between two media.

When a pulse is transmitted from one medium to another, like from a thin rope to a thicker one, the pulse will change where it meets the boundary of the two mediums (for example where the ropes are joined). When a pulse moves from a thin rope to a thicker one, the speed of the pulse will decrease. The pulse will move slower and the pulse length will increase.

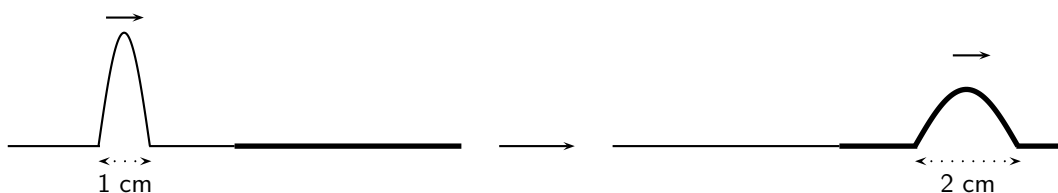

Figure 5.7: Reflection and transmission of a pulse at the boundary between two media.

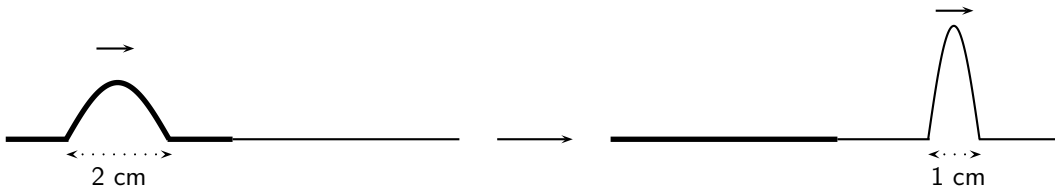

Figure 5.8: Reflection and transmission of a pulse at the boundary between two media.

When a pulse moves from a thick rope to a thinner one, the opposite happens. The pulse speed will increase and the pulse length will decrease.

When the speed of the pulse increases, the pulse length will decrease. If the speed decreases, the pulse length will increase. The **incident pulse** is the one that arrives at the boundary. The **reflected pulse** is the one that moves back, away from the boundary. The **transmitted pulse** is the one that moves into the new medium, away from the boundary.



Exercise: Pulses at a Boundary I

1. Fill in the blanks or select the correct answer: A pulse in a heavy rope is traveling towards the boundary with a thin piece of string.
 - (a) The reflected pulse in the heavy rope **will/will not** be inverted because _____.
 - (b) The speed of the transmitted pulse will be **greater than/less than/the same as** the speed of the incident pulse.
 - (c) The speed of the reflected pulse will be **greater than/less than/the same as** the speed of the incident pulse.
 - (d) The pulse length of the transmitted pulse will be **greater than/less than/the same as** the pulse length of the incident pulse.
 - (e) The frequency of the transmitted pulse will be **greater than/less than/the same as** the frequency of the incident pulse.
2. A pulse in a light string is traveling towards the boundary with a heavy rope.
 - (a) The reflected pulse in the light rope **will/will not** be inverted because _____.
 - (b) The speed of the transmitted pulse will be **greater than/less than/the same as** the speed of the incident pulse.
 - (c) The speed of the reflected pulse will be **greater than/less than/the same as** the speed of the incident pulse.
 - (d) The pulse length of the transmitted pulse will be **greater than/less than/the same as** the pulse length of the incident pulse.

5.6 Reflection of a Pulse from Fixed and Free Ends

Let us now consider what happens to a pulse when it reaches the end of a medium. The medium can be fixed, like a rope tied to a wall, or it can be free, like a rope tied loosely to a pole.

5.6.1 Reflection of a Pulse from a Fixed End

Activity :: Investigation : Reflection of a Pulse from a Fixed End

Tie a rope to a wall or some other object that cannot move. Create a pulse in the rope by flicking one end up and down. Observe what happens to the pulse when it reaches the wall.

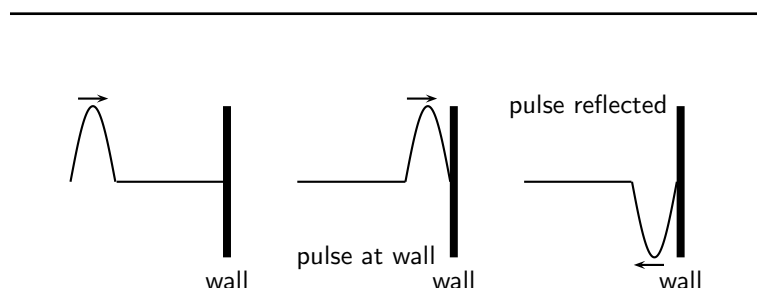

Figure 5.9: Reflection of a pulse from a fixed end.

When the end of the medium is fixed, for example a rope tied to a wall, a pulse reflects from the fixed end, but the pulse is inverted (i.e. it is upside-down). This is shown in Figure 5.9.

5.6.2 Reflection of a Pulse from a Free End**Activity :: Investigation : Reflection of a Pulse from a Free End**

Tie a rope to a pole in such a way that the rope can move up and down the pole. Create a pulse in the rope by flicking one end up and down. Observe what happens to the pulse when it reaches the pole.

When the end of the medium is free, for example a rope tied loosely to a pole, a pulse reflects from the free end, but the pulse is not inverted. This is shown in Figure 5.10. We draw the free end as a ring around the pole. The ring will move up and down the pole, while the pulse is reflected away from the pole.

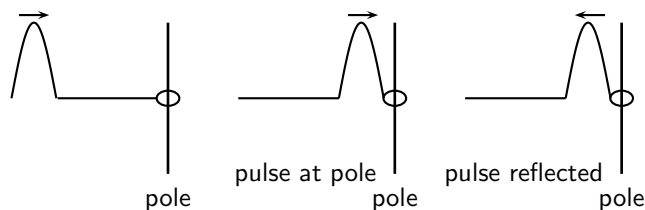

Figure 5.10: Reflection of a pulse from a free end.



Important: The fixed and free ends that were discussed in this section are examples of *boundary conditions*. You will see more of boundary conditions as you progress in the Physics syllabus.

**Exercise: Pulses at a Boundary II**

1. A rope is tied to a tree and a single pulse is generated. What happens to the pulse as it reaches the tree? Draw a diagram to explain what happens.
2. A rope is tied to a ring that is loosely fitted around a pole. A single pulse is sent along the rope. What will happen to the pulse as it reaches the pole? Draw a diagram to explain your answer.



5.7 Superposition of Pulses

Two or more pulses can pass through the same medium at that same time. The resulting pulse is obtained by using the *principle of superposition*. The principle of superposition states that the effect of the pulses is the sum of their individual effects. After pulses pass through each other, each pulse continues along its original direction of travel, and their original amplitudes remain unchanged.

Constructive interference takes place when two pulses meet each other to create a larger pulse. The amplitude of the resulting pulse is the sum of the amplitudes of the two initial pulses. This is shown in Figure 5.11.



Definition: Constructive interference is when two pulses meet, resulting in a bigger pulse.

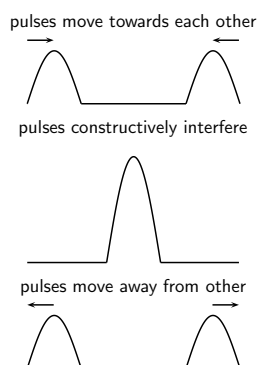

Figure 5.11: Superposition of two pulses: constructive interference.

Destructive interference takes place when two pulses meet and cancel each other. The amplitude of the resulting pulse is the sum of the amplitudes of the two initial pulses, but the one amplitude will be a negative number. This is shown in Figure 5.12. In general, amplitudes of individual pulses add together to give the amplitude of the resultant pulse.



Definition: Destructive interference is when two pulses meet, resulting in a smaller pulse.

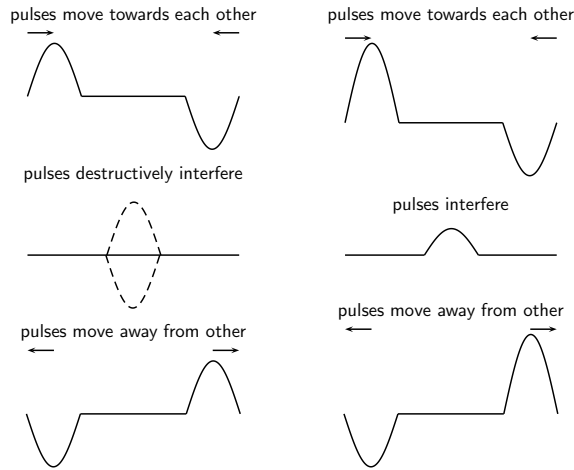
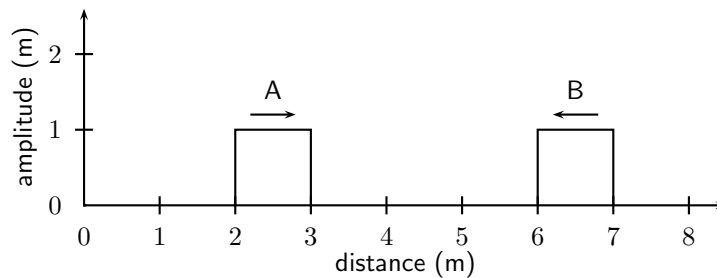

Figure 5.12: Superposition of two pulses. The left-hand series of images demonstrates destructive interference, since the pulses cancel each other. The right-hand series of images demonstrate a partial cancellation of two pulses, as their amplitudes are not the same in magnitude.



Worked Example 24: Superposition of Pulses

Question: The two pulses shown below approach each other at $1 \text{ m}\cdot\text{s}^{-1}$. Draw what the waveform would look like after 1 s, 2 s and 5 s.



Answer

Step 1 : After 1 s

After 1 s, pulse A has moved 1 m to the right and pulse B has moved 1 m to the left.

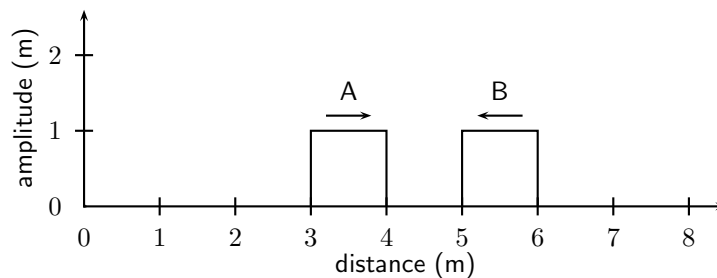

Step 2 : After 2 s

After 1 s more, pulse A has moved 1 m to the right and pulse B has moved 1 m to the left.

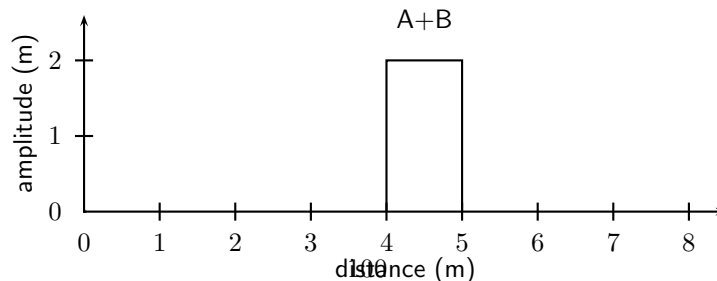

Step 3 : After 5 s



Important: The idea of superposition is one that occurs often in physics. You will see *much, much more* of superposition!



Exercise: Superposition of Pulses

1. For each of the following pulses, draw the resulting wave forms after 1 s, 2 s, 3 s, 4 s and 5 s. Each pulse is travelling at $1 \text{ m}\cdot\text{s}^{-1}$. Each block represents 1 m.



(a)

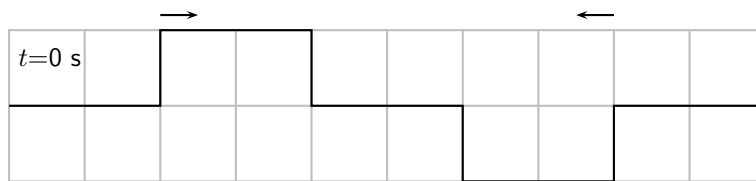

(b)

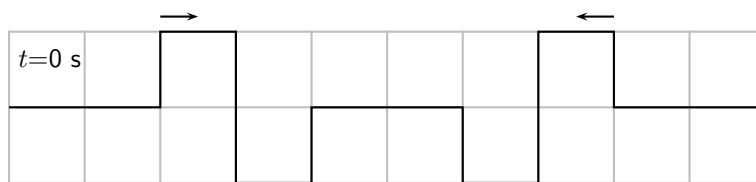

(c)

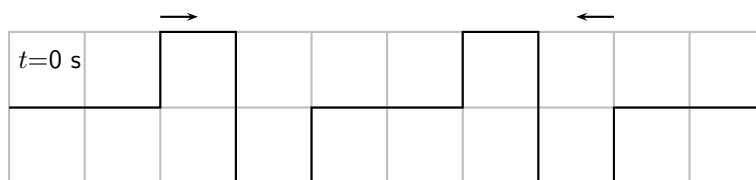

(d)

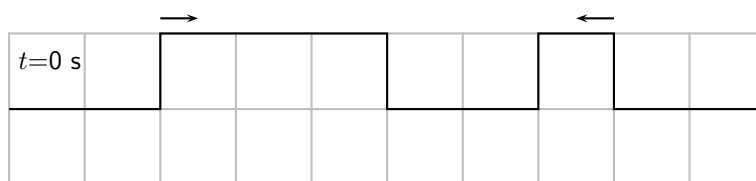

(e)

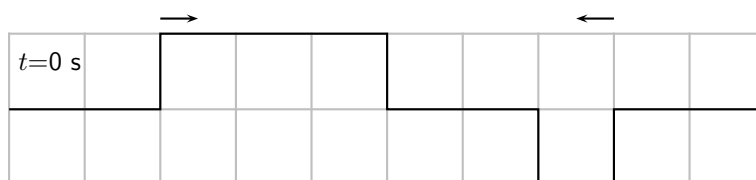

(f)

2. (a) What is superposition of waves?
 (b) What is constructive interference? Use the letter "c" to indicate where constructive interference took place in each of your answers for question 1. Only look at diagrams for $t = 3 \text{ s}$.
 (c) What is destructive interference? Use the letter "d" to indicate where destructive interference took place in each of your answers for question 1. Only look at diagrams for $t = 2 \text{ s}$.

5.8 Exercises - Transverse Pulses

- A heavy rope is flicked upwards, creating a single pulse in the rope. Make a drawing of the rope and indicate the following in your drawing:
 - The direction of motion of the pulse
 - Amplitude
 - Pulse length
 - Position of rest
- A pulse has a speed of $2,5\text{m}\cdot\text{s}^{-1}$. How far will it have travelled in 6s?
- A pulse covers a distance of 75cm in 2,5s. What is the speed of the pulse?
- How long does it take a pulse to cover a distance of 200mm if its speed is $4\text{m}\cdot\text{s}^{-1}$?
- The following position-time graph for a pulse in a slinky spring is given. Draw an accurate sketch graph of the velocity of the pulse against time.

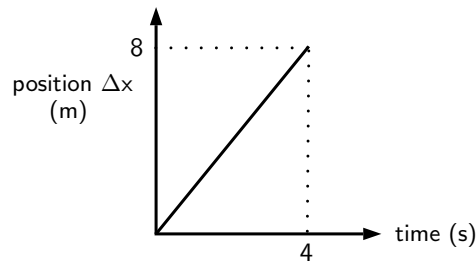

- The following velocity-time graph for a particle in a medium is given. Draw an accurate sketch graph of the position of the particle vs. time.

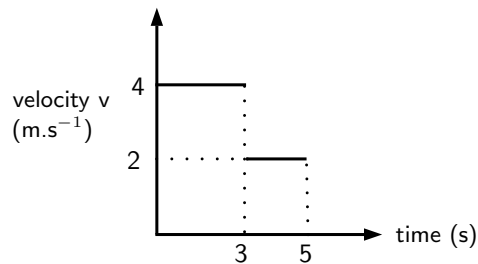

- Describe what happens to a pulse in a slinky spring when:
 - the slinky spring is tied to a wall.
 - the slinky spring is loose, i.e. not tied to a wall.
 (Draw diagrams to explain your answers.)
- The following diagrams each show two approaching pulses. Redraw the diagrams to show what type of interference takes place, and label the type of interference.

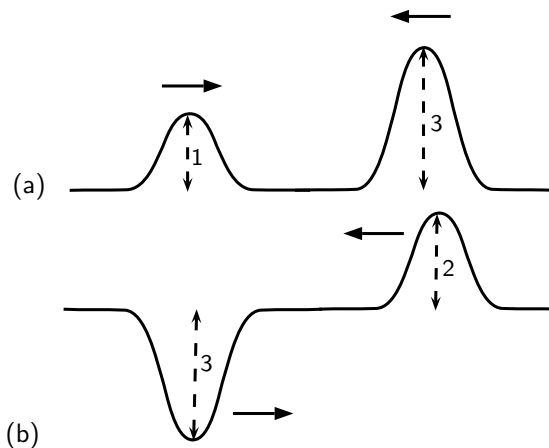

9. Two pulses, A and B, of identical frequency and amplitude are simultaneously generated in two identical wires of equal mass and length. Wire A is, however, pulled tighter than wire. Which pulse will arrive at the other end first, or will they both arrive at the same time?

Chapter 6

Transverse Waves - Grade 10

6.1 Introduction

Waves occur frequently in nature. The most obvious examples are waves in water, on a dam, in the ocean, or in a bucket. We are most interested in the properties that waves have. All waves have the same properties, so if we study waves in water, then we can transfer our knowledge to predict how other examples of waves will behave.

6.2 What is a transverse wave?

We have studied pulses in Chapter 5, and know that a pulse is a single disturbance that travels through a medium. A *wave* is a periodic, continuous disturbance that consists of a *train* of pulses.



Definition: Wave

A *wave* is a periodic, continuous disturbance that consists of a *train* of pulses.



Definition: Transverse wave

A *transverse wave* is a wave where the movement of the particles of the medium is perpendicular to the direction of propagation of the wave.

Activity :: Investigation : Transverse Waves

Take a rope or slinky spring. Have two people hold the rope or spring stretched out horizontally. Flick the one end of the rope up and down **continuously** to create a *train of pulses*.

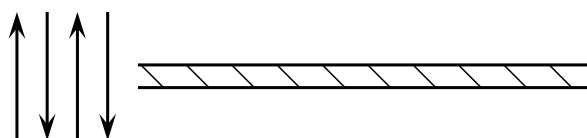

Flick rope up and down

1. Describe what happens to the rope.
2. Draw a diagram of what the rope looks like while the pulses travel along it.

3. In which direction do the pulses travel?
4. Tie a ribbon to the middle of the rope. This indicates a particle in the rope.

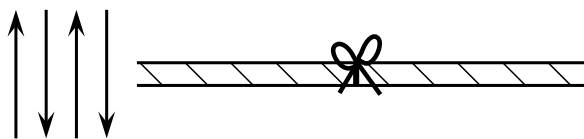

Flick rope up and down

5. Flick the rope continuously. Watch the ribbon carefully as the pulses travel through the rope. What happens to the ribbon?
6. Draw a picture to show the motion of the ribbon. Draw the ribbon as a dot and use arrows.

In the Activity, you have created waves. The medium through which these waves propagated was the rope, which is obviously made up of a very large number of particles (atoms). From the activity, you would have noticed that the wave travelled from left to right, but the particles (the ribbon) moved only up and down.

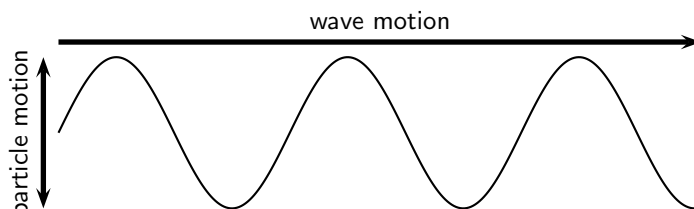

Figure 6.1: A transverse wave, showing the direction of motion of the wave perpendicular to the direction in which the particles move.

When the particles of a medium move at right angles to the direction of propagation of a wave, the wave is called *transverse*. For waves, there is no net displacement of the particles (they return to their equilibrium position), but there is a net displacement of the wave. There are thus two different motions: the motion of the particles of the medium and the motion of the wave.

6.2.1 Peaks and Troughs

Waves consist of moving *peaks* (or *crests*) and *troughs*. A peak is the highest point the medium rises to and a trough is the lowest point the medium sinks to.

Peaks and troughs on a transverse wave are shown in Figure 6.2.

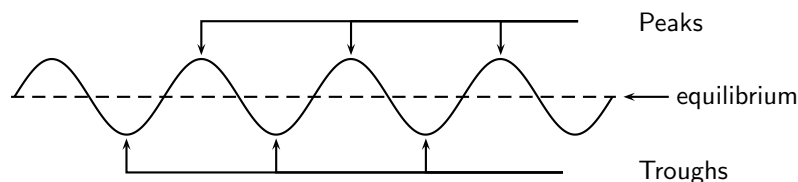

Figure 6.2: Peaks and troughs in a transverse wave.

Definition: Peaks and troughs

A *peak* is a point on the wave where the displacement of the medium is at a maximum. A point on the wave is a *trough* if the displacement of the medium at that point is at a minimum.



6.2.2 Amplitude and Wavelength

There are a few properties that we saw with pulses that also apply to waves. These are amplitude and wavelength (we called this pulse length).



Definition: Amplitude

The *amplitude* is the maximum displacement of a particle from its equilibrium position.

Activity :: Investigation : Amplitude

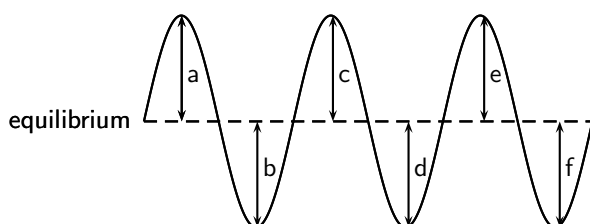

Fill in the table below by measuring the distance between the equilibrium and each peak and troughs in the wave above. Use your ruler to measure the distances.

Peak/Trough	Measurement (cm)
a	
b	
c	
d	
e	
f	

1. What can you say about your results?
2. Are the distances between the equilibrium position and each peak equal?
3. Are the distances between the equilibrium position and each trough equal?
4. Is the distance between the equilibrium position and peak equal to the distance between equilibrium and trough?

As we have seen in the activity on amplitude, the distance between the peak and the equilibrium position is equal to the distance between the trough and the equilibrium position. This distance is known as the *amplitude* of the wave, and is the characteristic height of wave, above or below the equilibrium position. Normally the symbol A is used to represent the amplitude of a wave. The SI unit of amplitude is the metre (m).

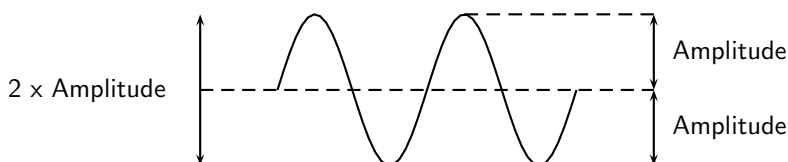



Worked Example 25: Amplitude of Sea Waves

Question: If the peak of a wave measures 2m above the still water mark in the harbour, what is the amplitude of the wave?

Answer

The definition of the amplitude is the height that the water rises to above when it is still. This is exactly what we were told, so the amplitude is 2m.

Activity :: Investigation : Wavelength

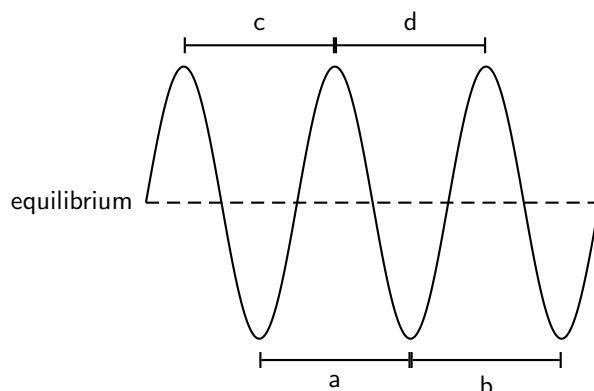

Fill in the table below by measuring the distance between peaks and troughs in the wave above.

	Distance(cm)
a	
b	
c	
d	

1. What can you say about your results?
2. Are the distances between peaks equal?
3. Are the distances between troughs equal?
4. Is the distance between peaks equal to the distance between troughs?

As we have seen in the activity on wavelength, the distance between two *adjacent* peaks is the same no matter which two adjacent peaks you choose. There is a fixed distance between the peaks. Similarly, we have seen that there is a fixed distance between the troughs, no matter which two troughs you look at. More importantly, the distance between two adjacent peaks is the same as the distance between two adjacent troughs. This distance is called the *wavelength* of the wave.

The symbol for the wavelength is λ (the Greek letter *lambda*) and wavelength is measured in metres (m).

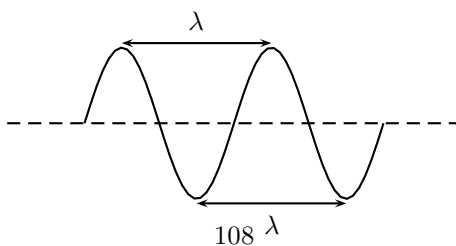



Worked Example 26: Wavelength

Question: The total distance between 4 consecutive peaks of a transverse wave is 6 m. What is the wavelength of the wave?

Answer

Step 1 : Draw a rough sketch of the situation

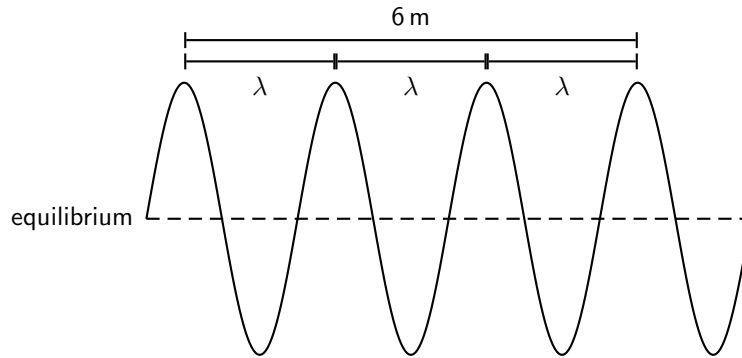

Step 2 : Determine how to approach the problem

From the sketch we see that 4 consecutive peaks is equivalent to 3 wavelengths.

Step 3 : Solve the problem

Therefore, the wavelength of the wave is:

$$\begin{aligned} 3\lambda &= 6 \text{ m} \\ \lambda &= \frac{6 \text{ m}}{3} \\ &= 2 \text{ m} \end{aligned}$$

6.2.3 Points in Phase

Activity :: Investigation : Points in Phase

Fill in the table by measuring the distance between the indicated points.

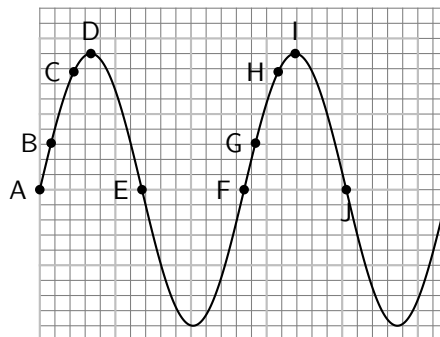

Points	Distance (cm)
A to F	
B to G	
C to H	
D to I	
E to J	

What do you find?

In the activity the distance between the indicated points was the same. These points are then said to be *in phase*. Two points in phase are separate by an integer (0,1,2,3,...) number of complete wave cycles. They do not have to be peaks or troughs, but they must be separated by a complete number of wavelengths.

We then have an alternate definition of the wavelength as the distance between any two adjacent points which are *in phase*.



Definition: Wavelength of wave

The wavelength of a wave is the distance between any two adjacent points that are in phase.

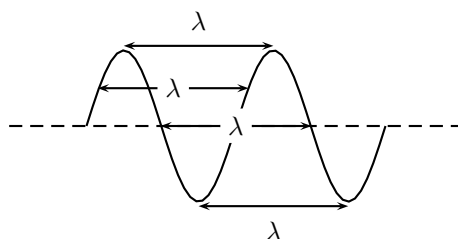

Points that are not in phase, those that are not separated by a complete number of wavelengths, are called *out of phase*. Examples of points like these would be *A* and *C*, or *D* and *E*, or *B* and *H* in the Activity.

6.2.4 Period and Frequency

Imagine you are sitting next to a pond and you watch the waves going past you. First one peak arrives, then a trough, and then another peak. Suppose you measure the time taken between one peak arriving and then the next. This time will be the same for any two successive peaks passing you. We call this time the *period*, and it is a characteristic of the wave.

The symbol T is used to represent the period. The period is measured in seconds (s).



Definition: The period (T) is the time taken for two successive peaks (or troughs) to pass a fixed point.

Imagine the pond again. Just as a peak passes you, you start your stopwatch and count each peak going past. After 1 second you stop the clock and stop counting. The number of peaks that you have counted in the 1 second is the *frequency* of the wave.



Definition: The frequency is the number of successive peaks (or troughs) passing a given point in 1 second.

The frequency and the period are related to each other. As the period is the time taken for 1 peak to pass, then the number of peaks passing the point in 1 second is $\frac{1}{T}$. But this is the frequency. So

$$f = \frac{1}{T}$$

or alternatively,

$$T = \frac{1}{f}$$

For example, if a wave takes $\frac{1}{2}$ s to go by then the period of the wave is $\frac{1}{2}$ s. Therefore, the frequency of the wave is:

$$\begin{aligned} f &= \frac{1}{T} \\ &= \frac{1}{\frac{1}{2}\text{s}} \\ &= 2\text{s}^{-1} \end{aligned}$$

The unit of frequency is the Hertz (Hz) or s^{-1} .



Worked Example 27: Period and Frequency

Question: What is the period of a wave of frequency 10 Hz?

Answer

Step 1 : Determine what is given and what is required

We are required to calculate the period of a 10 Hz wave.

Step 2 : Determine how to approach the problem

We know that:

$$T = \frac{1}{f}$$

Step 3 : Solve the problem

$$\begin{aligned} T &= \frac{1}{f} \\ &= \frac{1}{10\text{ Hz}} \\ &= 0,1\text{ m} \end{aligned}$$

Step 4 : Write the answer

The period of a 10 Hz wave is 0,1 m.

6.2.5 Speed of a Transverse Wave

In Chapter 3, we saw that speed was defined as

$$\text{speed} = \frac{\text{distance travelled}}{\text{time taken}}$$

The distance between two successive peaks is 1 wavelength, λ . Thus in a time of 1 period, the wave will travel 1 wavelength in distance. Thus the speed of the wave, v , is:

$$v = \frac{\text{distance travelled}}{\text{time taken}} = \frac{\lambda}{T}$$

However, $f = \frac{1}{T}$. Therefore, we can also write:

$$\begin{aligned} v &= \frac{\lambda}{T} \\ &= \lambda \cdot \frac{1}{T} \\ &= \lambda \cdot f \end{aligned}$$

We call this equation the *wave equation*. To summarise, we have that $v = \lambda \cdot f$ where

- $v = \text{speed in m}\cdot\text{s}^{-1}$

- λ = wavelength in m
- f = frequency in Hz



Worked Example 28: Speed of a Transverse Wave 1

Question: When a particular string is vibrated at a frequency of 10 Hz, a transverse wave of wavelength 0,25 m is produced. Determine the speed of the wave as it travels along the string.

Answer

Step 1 : Determine what is given and what is required

- frequency of wave: $f = 10$ Hz
- wavelength of wave: $\lambda = 0,25$ m

We are required to calculate the speed of the wave as it travels along the string. All quantities are in SI units.

Step 2 : Determine how to approach the problem

We know that the speed of a wave is:

$$v = f \cdot \lambda$$

and we are given all the necessary quantities.

Step 3 : Substituting in the values

$$\begin{aligned} v &= f \cdot \lambda \\ &= (10 \text{ Hz})(0,25 \text{ m}) \\ &= 2,5 \text{ m} \cdot \text{s}^{-1} \end{aligned}$$

Step 4 : Write the final answer

The wave travels at $2,5 \text{ m} \cdot \text{s}^{-1}$ in the string.



Worked Example 29: Speed of a Transverse Wave 2

Question: A cork on the surface of a swimming pool bobs up and down once per second on some ripples. The ripples have a wavelength of 20 cm. If the cork is 2 m from the edge of the pool, how long does it take a ripple passing the cork to reach the shore?

Answer

Step 1 : Determine what is given and what is required

We are given:

- frequency of wave: $f = 1$ Hz
- wavelength of wave: $\lambda = 20$ cm
- distance of leaf from edge of pool: $d = 2$ m

We are required to determine the time it takes for a ripple to travel between the cork and the edge of the pool.

The wavelength is not in SI units and should be converted.

Step 2 : Determine how to approach the problem

The time taken for the ripple to reach the edge of the pool is obtained from:

$$t = \frac{d}{v} \quad \left(\text{from } v = \frac{d}{t}\right)$$

We know that

$$v = f \cdot \lambda$$

Therefore,

$$t = \frac{d}{f \cdot \lambda}$$

Step 3 : Convert wavelength to SI units

$$20 \text{ cm} = 0,2 \text{ m}$$

Step 4 : Solve the problem

$$\begin{aligned} t &= \frac{d}{f \cdot \lambda} \\ &= \frac{2 \text{ m}}{(1 \text{ Hz})(0,2 \text{ m})} \\ &= 10 \text{ s} \end{aligned}$$

Step 5 : Write the final answer

A ripple passing the leaf will take 10s to reach the edge of the pool.



Exercise: Waves

1. List one property that distinguishes waves from matter.
2. When the particles of a medium move perpendicular to the direction of the wave motion, the wave is called a wave.
3. A transverse wave is moving downwards. In what direction do the particles in the medium move?
4. Consider the diagram below and answer the questions that follow:

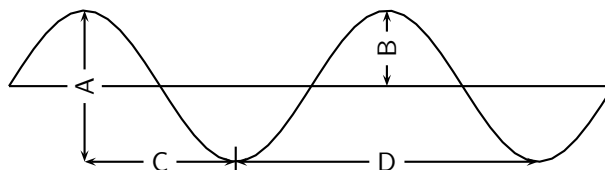

- (a) the wavelength of the wave is shown by letter
- (b) the amplitude of the wave is shown by letter
5. Draw 2 wavelengths of the following transverse waves on the same graph paper. Label all important values.
 - (a) Wave 1: Amplitude = 1 cm, wavelength = 3 cm
 - (b) Wave 2: Peak to trough distance (vertical) = 3 cm, peak to peak distance (horizontal) = 5 cm
6. You are given the transverse wave below.

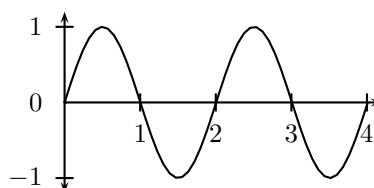

Draw the following:

- (a) A wave with twice the amplitude of the given wave.
- (b) A wave with half the amplitude of the given wave.

- (c) A wave with twice the frequency of the given wave.
 (d) A wave with half the frequency of the given wave.
 (e) A wave with twice the wavelength of the given wave.
 (f) A wave with half the wavelength of the given wave.
 (g) A wave with twice the period of the given wave.
 (h) A wave with half the period of the given wave.
7. A transverse wave with an amplitude of 5 cm has a frequency of 15 Hz. The horizontal distance from a crest to the nearest trough is measured to be 2,5 cm. Find the
 (a) period of the wave.
 (b) speed of the wave.
8. A fly flaps its wings back and forth 200 times each second. Calculate the period of a wing flap.
9. As the period of a wave increases, the frequency **increases/decreases/does not change**.
10. Calculate the frequency of rotation of the second hand on a clock.
11. Microwave ovens produce radiation with a frequency of 2 450 MHz (1 MHz = 10^6 Hz) and a wavelength of 0,122 m. What is the wave speed of the radiation?
12. Study the following diagram and answer the questions:

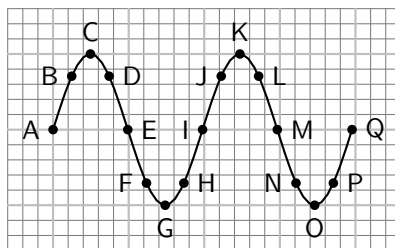

- (a) Identify two sets of points that are in phase.
 (b) Identify two sets of points that are out of phase.
 (c) Identify any two points that would indicate a wavelength.
13. Tom is fishing from a pier and notices that four wave crests pass by in 8 s and estimates the distance between two successive crests is 4 m. The timing starts with the first crest and ends with the fourth. Calculate the speed of the wave.
-

6.3 Graphs of Particle Motion

In Chapter 5, we saw that when a pulse moves through a medium, there are two different motions: the motion of the particles of the medium and the motion of the pulse. These two motions are at right angles to each other when the pulse is transverse. Since a transverse wave is a series of transverse pulses, the particle in the medium and the wave move in exactly the same way as for the pulse.

When a transverse wave moves through the medium, the particles in the medium **only** move up and down. We can see this in the figure below, which shows the motion of a single particle as a transverse wave moves through the medium.

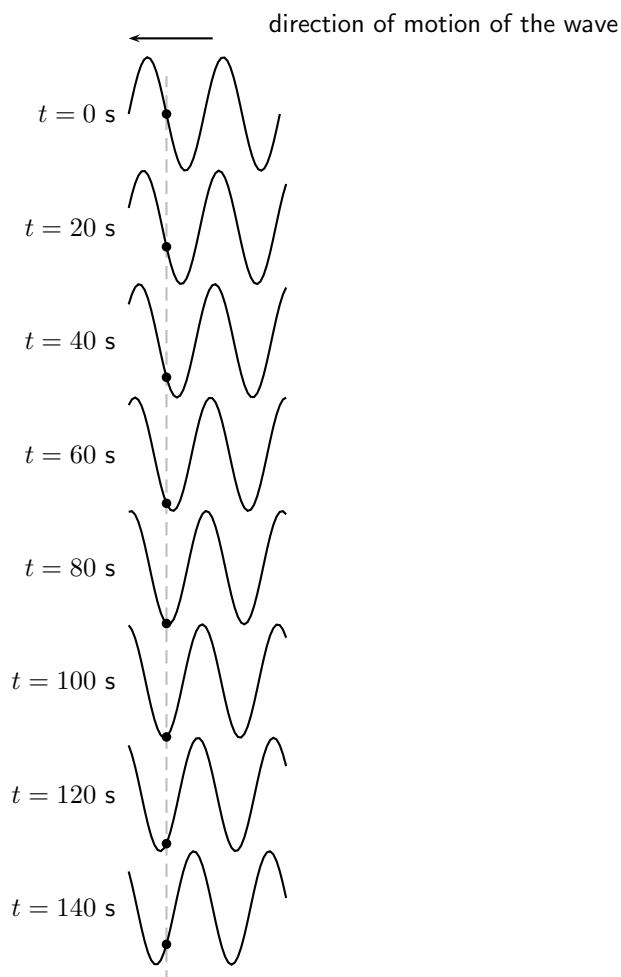

Important: A particle in the medium **only** moves up and down when a transverse wave moves through the medium.

As in Chapter 3, we can draw a graph of the particles' position as a function of time. For the wave shown in the above figure, we can draw the graph shown below.

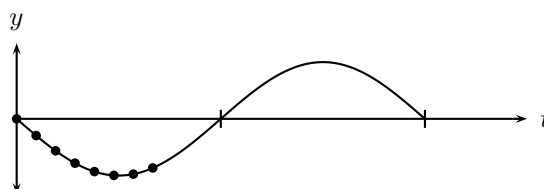

Graph of particle position as a function of time.

The graph of the particle's velocity as a function of time is obtained by taking the gradient of the position vs. time graph. The graph of velocity vs. time for the position vs. time graph above, is shown in the graph below.

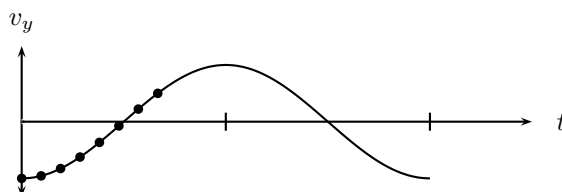

Graph of particle velocity as a function of time.

The graph of the particle's acceleration as a function of time is obtained by taking the gradient of the velocity vs. time graph. The graph of acceleration vs. time for the position vs. time graph shown above, is shown below.

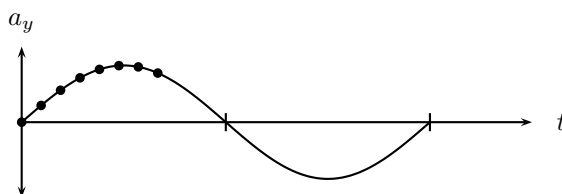

Graph of particle acceleration as a function of time.

As for motion in one dimension, these graphs can be used to describe the motion of the particle. This is illustrated in the worked examples below.



Worked Example 30: Graphs of particle motion 1

Question: The following graph shows the position of a particle of a wave as a function of time.

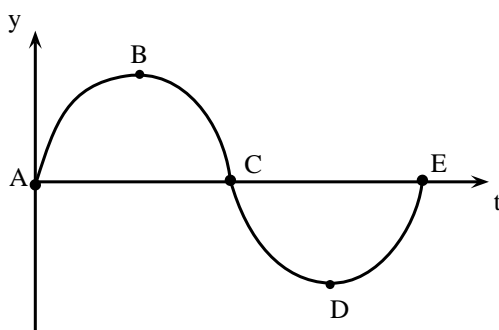

1. Draw the corresponding velocity vs. time graph for the particle.
2. Draw the corresponding acceleration vs. time graph for the particle.

Answer

Step 1 : Determine what is given and what is required.

The y vs. t graph is given.

The v_y vs. t and a_y vs. t graphs are required.

Step 2 : Draw the velocity vs. time graph

To find the velocity of the particle we need to find the gradient of the y vs. t graph at each time.

At point A the gradient is a maximum and positive.
 At point B the gradient is zero.
 At point C the gradient is a maximum, but negative.
 At point D the gradient is zero.
 At point E the gradient is a maximum and positive again.

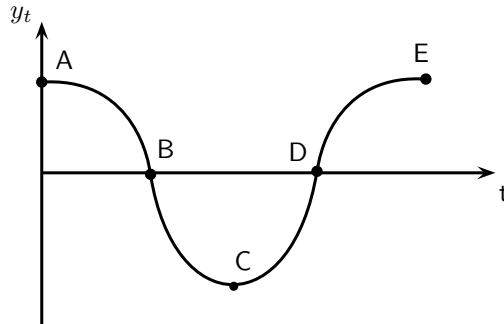

Step 3 : Draw the acceleration vs. time graph

To find the acceleration of the particle we need to find the gradient of the v_y vs. t graph at each time.

At point A the gradient is zero.
 At point B the gradient is negative and a maximum.
 At point C the gradient is zero.
 At point D the gradient is positive and a maximum.
 At point E the gradient is zero.

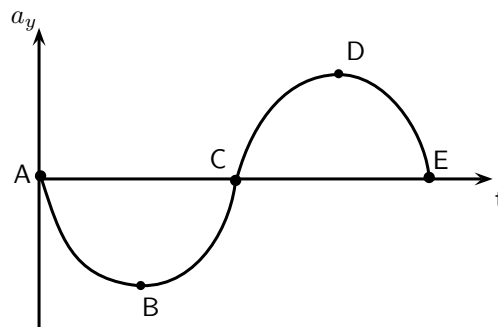

Extension: Mathematical Description of Waves

If you look carefully at the pictures of waves you will notice that they look very much like *sine* or *cosine* functions. This is correct. Waves can be described by trigonometric functions that are functions of time or of position. Depending on which case we are dealing with the function will be a function of t or x . For example, a function of position would be:

$$y(x) = A \sin(k \frac{x}{\lambda})$$

while a function of time would be:

$$y(t) = A \sin(k \frac{t}{T})$$

Descriptions of the wave incorporate the amplitude, wavelength, frequency or period and a phase shift.



Exercise: Graphs of Particle Motion

1. The following velocity vs. time graph for a particle in a wave is given.

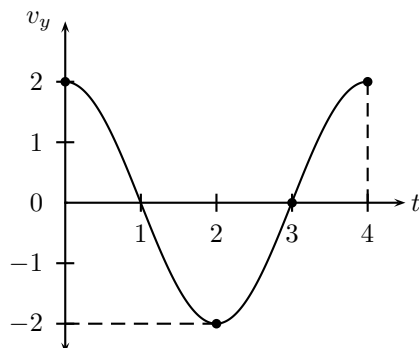

- (a) Draw the corresponding position vs. time graph for the particle.
 (b) Draw the corresponding acceleration vs. time graph for the particle.

6.4 Standing Waves and Boundary Conditions

6.4.1 Reflection of a Transverse Wave from a Fixed End

We have seen that when a pulse meets a fixed endpoint, the pulse is reflected, but it is inverted. Since a transverse wave is a series of pulses, a transverse wave meeting a fixed endpoint is also reflected and the reflected wave is inverted. That means that the peaks and troughs are swapped around.

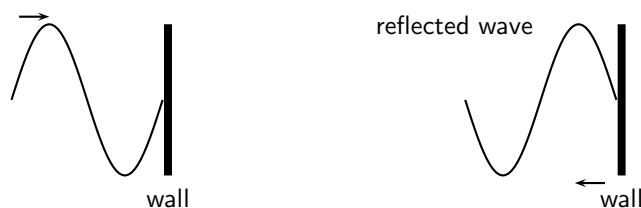

Figure 6.3: Reflection of a transverse wave from a fixed end.

6.4.2 Reflection of a Transverse Wave from a Free End

If transverse waves are reflected from an end, which is free to move, the waves sent down the string are reflected but do not suffer a phase shift as shown in Figure 6.4.

6.4.3 Standing Waves

What happens when a reflected transverse wave meets an incident transverse wave? When two waves move in opposite directions, through each other, interference takes place. If the two waves have the same frequency and wavelength then *standing waves* are generated.

Standing waves are so-called because they appear to be standing still.

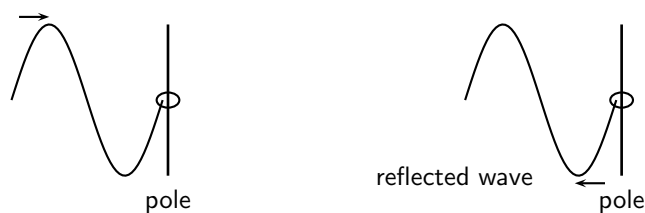

Figure 6.4: Reflection of a transverse wave from a free end.

Activity :: Investigation : Creating Standing Waves

Tie a rope to a fixed object such that the tied end does not move. Continuously move the free end up and down to generate firstly transverse waves and later standing waves.

We can now look closely how standing waves are formed. Figure 6.5 shows a reflected wave meeting an incident wave.

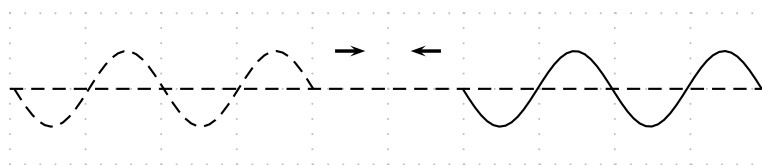

Figure 6.5: A reflected wave (solid line) approaches the incident wave (dashed line).

When they touch, both waves have an amplitude of zero:

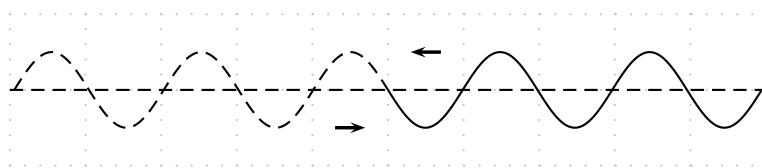

Figure 6.6: A reflected wave (solid line) meets the incident wave (dashed line).

If we wait for a short time the ends of the two waves move past each other and the waves overlap. To find the resultant wave, we add the two together.

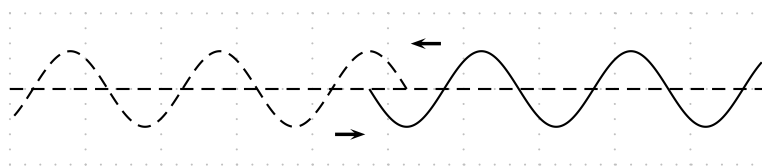
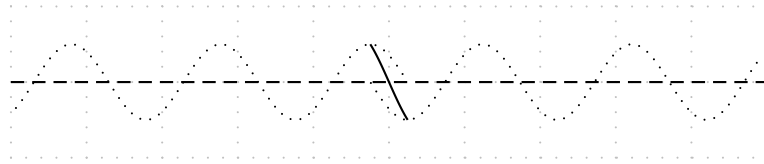
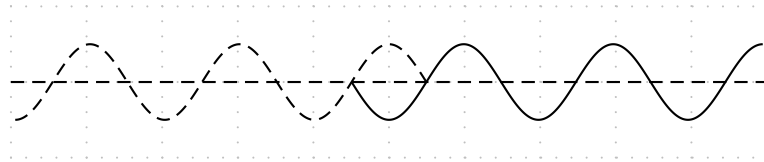

Figure 6.7: A reflected wave (solid line) overlaps slightly with the incident wave (dashed line).

In this picture, we show the two waves as dotted lines and the sum of the two in the overlap region is shown as a solid line:



The important thing to note in this case is that there are some points where the two waves always destructively interfere to zero. If we let the two waves move a little further we get the picture below:



Again we have to add the two waves together in the overlap region to see what the sum of the waves looks like.

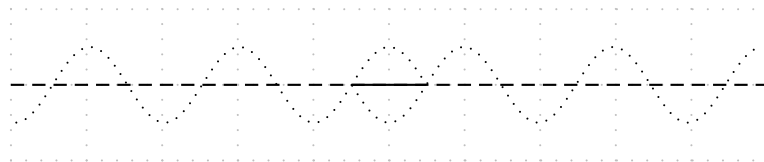

In this case the two waves have moved half a cycle past each other but because they are out of phase they cancel out completely.

When the waves have moved past each other so that they are overlapping for a large region the situation looks like a wave oscillating in place. The following sequence of diagrams show what the resulting wave will look like. To make it clearer, the arrows at the top of the picture show peaks where maximum positive constructive interference is taking place. The arrows at the bottom of the picture show places where maximum negative interference is taking place.

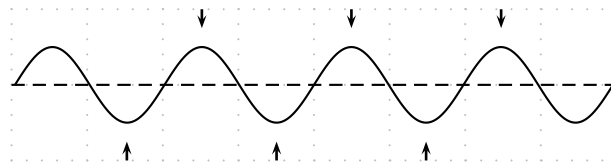

As time goes by the peaks become smaller and the troughs become shallower but they do not move.

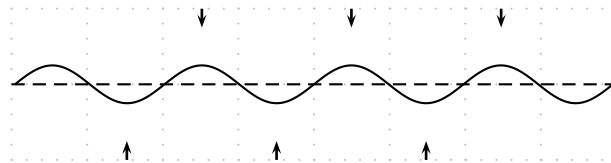

For an instant the entire region will look completely flat.

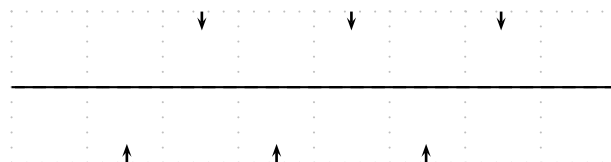

The various points continue their motion in the same manner.

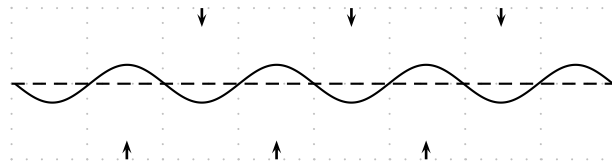

Eventually the picture looks like the complete reflection through the x -axis of what we started with:

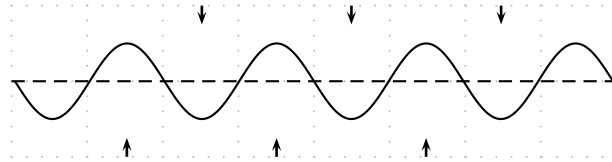

Then all the points begin to move back. Each point on the line is oscillating up and down with a different amplitude.

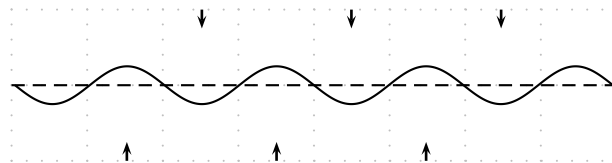

If we look at the overall result, we get a standing wave.

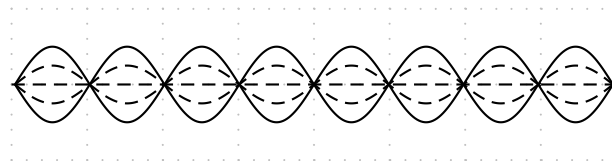
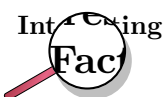

Figure 6.8: A standing wave

If we superimpose the two cases where the peaks were at a maximum and the case where the same waves were at a minimum we can see the lines that the points oscillate between. We call this the *envelope* of the standing wave as it contains all the oscillations of the individual points. To make the concept of the envelope clearer let us draw arrows describing the motion of points along the line.



Every point in the medium containing a standing wave oscillates up and down and the amplitude of the oscillations depends on the location of the point. It is convenient to draw the envelope for the oscillations to describe the motion. We cannot draw the up and down arrows for every single point!



Standing waves can be a problem in for example indoor concerts where the dimensions of the concert venue coincide with particular wavelengths. Standing waves can appear as 'feedback', which would occur if the standing wave was picked up by the microphones on stage and amplified.

6.4.4 Nodes and anti-nodes

A node is a point on a wave where no displacement takes place. In a standing wave, a node is a place where the two waves cancel out completely as two waves destructively interfere in the same place. A fixed end of a rope is a node. An anti-node is a point on a wave where maximum displacement takes place. In a standing wave, an anti-node is a place where the two waves constructively interfere. A free end of a rope is an anti-node.

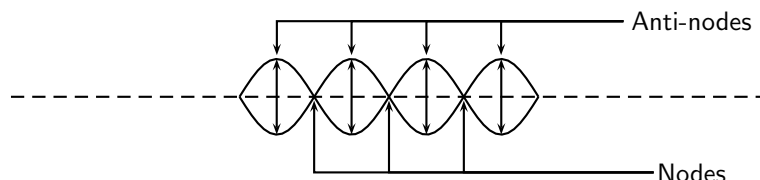

Definition: Node

A node is a point on a wave where no displacement takes place. In a standing wave, a node is a place where the two waves cancel out completely as two waves destructively interfere in the same place. A fixed end of a rope is a node.

Definition: Anti-Node

An anti-node is a point on a wave where maximum displacement takes place. In a standing wave, an anti-node is a place where the two waves constructively interfere. A free end of a rope is an anti-node.

Important: The distance between two anti-nodes is only $\frac{1}{2}\lambda$ because it is the distance from a peak to a trough in one of the waves forming the standing wave. It is the same as the distance between two adjacent nodes. This will be important when we work out the allowed wavelengths in tubes later. We can take this further because half-way between any two anti-nodes is a node. Then the distance from the node to the anti-node is half the distance between two anti-nodes. This is half of half a wavelength which is one quarter of a wavelength, $\frac{1}{4}\lambda$.

6.4.5 Wavelengths of Standing Waves with Fixed and Free Ends

There are many applications which make use of the properties of waves and the use of fixed and free ends. Most musical instruments rely on the basic picture that we have presented to create specific sounds, either through standing pressure waves or standing vibratory waves in strings.

The key is to understand that a standing wave must be created in the medium that is oscillating. There are restrictions as to what wavelengths can form standing waves in a medium.

For example, if we consider a rope that can move in a pipe such that it can have

- both ends free to move (Case 1)
- one end free and one end fixed (Case 2)
- both ends fixed (Case 3).

Each of these cases is slightly different because the free or fixed end determines whether a node or anti-node will form when a standing wave is created in the rope. These are the main restrictions when we determine the wavelengths of potential standing waves. These restrictions are known as *boundary conditions* and **must** be met.

In the diagram below you can see the three different cases. It is possible to create standing waves with different frequencies and wavelengths as long as the end criteria are met.

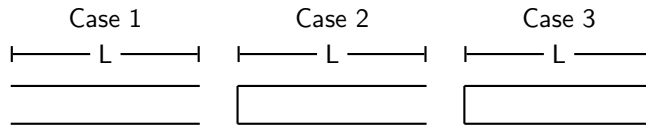

The longer the wavelength the less the number of anti-nodes in the standing waves. We cannot have a standing wave with no anti-nodes because then there would be no oscillations. We use n to number the anti-nodes. If all of the tubes have a length L and we know the end constraints we can find the wavelength, λ , for a specific number of anti-nodes.

One Node

Let's work out the longest wavelength we can have in each tube, i.e. the case for $n = 1$.

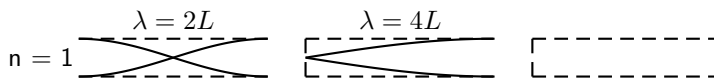

Case 1: In the first tube, both ends must be nodes, so we can place one anti-node in the middle of the tube. We know the distance from one node to another is $\frac{1}{2}\lambda$ and we also know this distance is L . So we can equate the two and solve for the wavelength:

$$\begin{aligned} \frac{1}{2}\lambda &= L \\ \lambda &= 2L \end{aligned}$$

Case 2: In the second tube, one end must be a node and the other must be an anti-node. We are looking at the case with one anti-node we are forced to have it at the end. We know the distance from one node to another is $\frac{1}{2}\lambda$ but we only have half this distance contained in the tube. So :

$$\begin{aligned} \frac{1}{2}\left(\frac{1}{2}\lambda\right) &= L \\ \lambda &= 4L \end{aligned}$$

Case 3: Here both ends are closed and so we must have two nodes so it is impossible to construct a case with only one node.

Two Nodes

Next we determine which wavelengths could be formed if we had two nodes. Remember that we are dividing the tube up into smaller and smaller segments by having more nodes so we expect the wavelengths to get shorter.

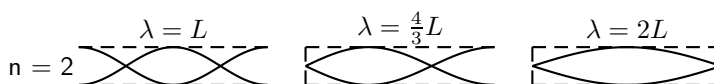

Case 1: Both ends are open and so they must be anti-nodes. We can have two nodes inside the tube only if we have one anti-node contained inside the tube and one on each end. This means we have 3 anti-nodes in the tube. The distance between any two anti-nodes is half a wavelength. This means there is half wavelength between the left side and the middle and another half wavelength between the middle and the right side so there must be one wavelength inside the tube. The safest thing to do is work out how many half wavelengths there are and equate this to the length of the tube L and then solve for λ .

$$\begin{aligned}2\left(\frac{1}{2}\lambda\right) &= L \\ \lambda &= L\end{aligned}$$

Case 2: We want to have two nodes inside the tube. The left end must be a node and the right end must be an anti-node. We can have one node inside the tube as drawn above. Again we can count the number of distances between adjacent nodes or anti-nodes. If we start from the left end we have one half wavelength between the end and the node inside the tube. The distance from the node inside the tube to the right end which is an anti-node is half of the distance to another node. So it is half of half a wavelength. Together these add up to the length of the tube:

$$\begin{aligned}\frac{1}{2}\lambda + \frac{1}{2}\left(\frac{1}{2}\lambda\right) &= L \\ \frac{2}{4}\lambda + \frac{1}{4}\lambda &= L \\ \frac{3}{4}\lambda &= L \\ \lambda &= \frac{4}{3}L\end{aligned}$$

Case 3: In this case both ends have to be nodes. This means that the length of the tube is one half wavelength: So we can equate the two and solve for the wavelength:

$$\begin{aligned}\frac{1}{2}\lambda &= L \\ \lambda &= 2L\end{aligned}$$



Important: If you ever calculate a longer wavelength for more nodes you have made a mistake. Remember to check if your answers make sense!

Three Nodes

To see the complete pattern for all cases we need to check what the next step for case 3 is when we have an additional node. Below is the diagram for the case where $n = 3$.

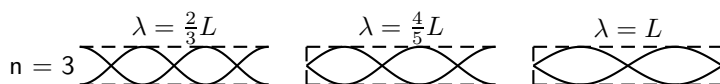

Case 1: Both ends are open and so they must be anti-nodes. We can have three nodes inside the tube only if we have two anti-nodes contained inside the tube and one on each end. This means we have 4 anti-nodes in the tube. The distance between any two anti-nodes is half a wavelength. This means there is half wavelength between every adjacent pair of anti-nodes. We count how many gaps there are between adjacent anti-nodes to determine how many half wavelengths there are and equate this to the length of the tube L and then solve for λ .

$$\begin{aligned}3\left(\frac{1}{2}\lambda\right) &= L \\ \lambda &= \frac{2}{3}L\end{aligned}$$

Case 2: We want to have three nodes inside the tube. The left end must be a node and the right end must be an anti-node, so there will be two nodes between the ends of the tube. Again

we can count the number of distances between adjacent nodes or anti-nodes, together these add up to the length of the tube. Remember that the distance between the node and an adjacent anti-node is only half the distance between adjacent nodes. So starting from the left end we count 3 nodes, so 2 half wavelength intervals and then only a node to anti-node distance:

$$\begin{aligned} 2\left(\frac{1}{2}\lambda\right) + \frac{1}{2}\left(\frac{1}{2}\lambda\right) &= L \\ \lambda + \frac{1}{4}\lambda &= L \\ \frac{5}{4}\lambda &= L \\ \lambda &= \frac{4}{5}L \end{aligned}$$

Case 3: In this case both ends have to be nodes. With one node in between there are two sets of adjacent nodes. This means that the length of the tube consists of two half wavelength sections:

$$\begin{aligned} 2\left(\frac{1}{2}\lambda\right) &= L \\ \lambda &= L \end{aligned}$$

6.4.6 Superposition and Interference

If two waves meet interesting things can happen. Waves are basically collective motion of particles. So when two waves meet they both try to impose their collective motion on the particles. This can have quite different results.

If two identical (same wavelength, amplitude and frequency) waves are both trying to form a peak then they are able to achieve the sum of their efforts. The resulting motion will be a peak which has a height which is the sum of the heights of the two waves. If two waves are both trying to form a trough in the same place then a deeper trough is formed, the depth of which is the sum of the depths of the two waves. Now in this case, the two waves have been trying to do the same thing, and so add together constructively. This is called *constructive interference*.

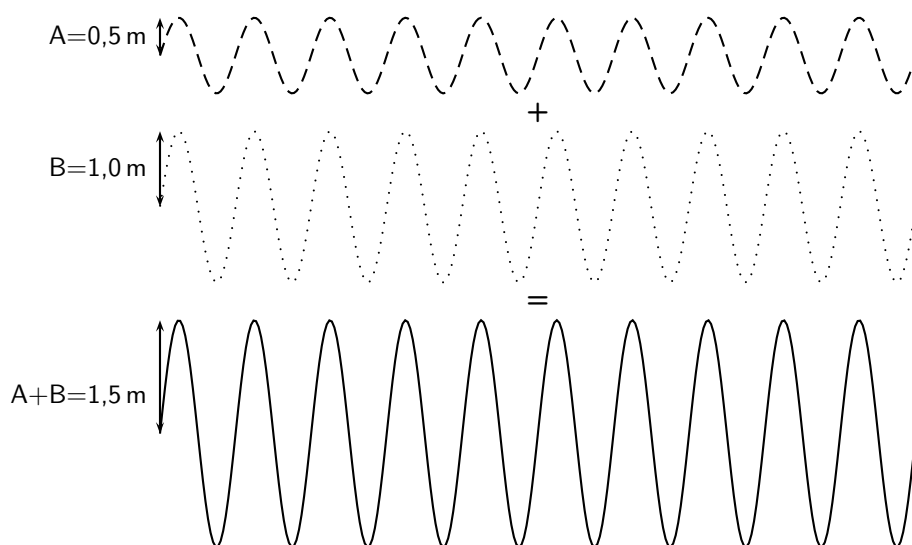

If one wave is trying to form a peak and the other is trying to form a trough, then they are competing to do different things. In this case, they can cancel out. The amplitude of the resulting wave will depend on the amplitudes of the two waves that are interfering. If the depth of the trough is the same as the height of the peak nothing will happen. If the height of the peak is bigger than the depth of the trough, a smaller peak will appear. And if the trough is deeper then a less deep trough will appear. This is *destructive interference*.

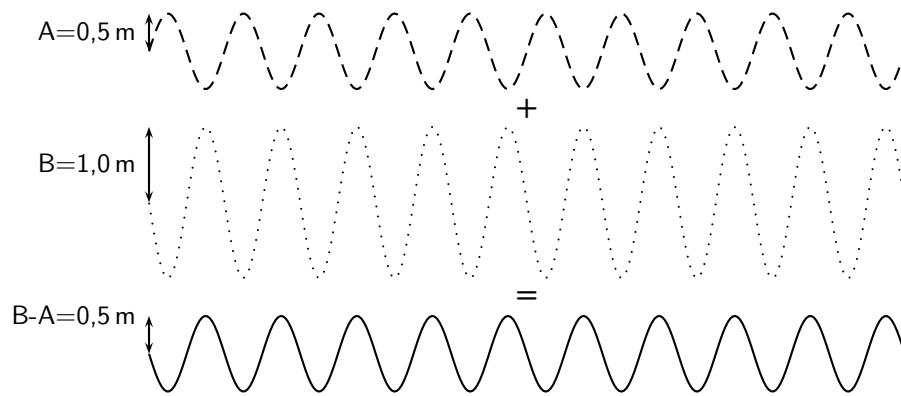

Exercise: Superposition and Interference

- For each labelled point, indicate whether constructive or destructive interference takes place at that point.

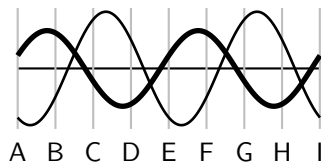

Position	Constructive/Destructive
A	
B	
C	
D	
E	
F	
G	
H	
I	

- A ride at the local amusement park is called "Standing on Waves". Which position (a node or an antinode) on the ride would give the greatest thrill?
- How many nodes and how many anti-nodes appear in the standing wave below?

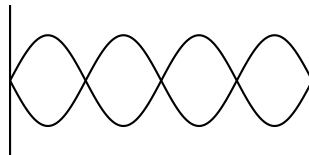

- For a standing wave on a string, you are given three statements:
 - you can have any λ and any f as long as the relationship, $v = \lambda \cdot f$ is satisfied.
 - only certain wavelengths and frequencies are allowed
 - the wave velocity is only dependent on the medium

Which of the statements are true:

- A and C only
 - B and C only
 - A, B, and C
 - none of the above
- Consider the diagram below of a standing wave on a string 9 m long that is tied at both ends. The wave velocity in the string is $16 \text{ m}\cdot\text{s}^{-1}$. What is the wavelength?

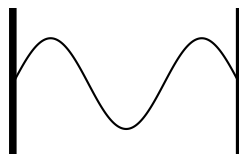

6.5 Summary

1. A wave is formed when a continuous number of pulses are transmitted through a medium.
2. A peak is the highest point a particle in the medium rises to.
3. A trough is the lowest point a particle in the medium sinks to.
4. In a transverse wave, the particles move perpendicular to the motion of the wave.
5. The amplitude is the maximum distance from equilibrium position to a peak (or trough), or the maximum displacement of a particle in a wave from its position of rest.
6. The wavelength (λ) is the distance between any two adjacent points on a wave that are in phase. It is measured in metres.
7. The period (T) of a wave is the time it takes a wavelength to pass a fixed point. It is measured in seconds (s).
8. The frequency (f) of a wave is how many waves pass a point in a second. It is measured in hertz (Hz) or s^{-1} .
9. Frequency: $f = \frac{1}{T}$
10. Period: $T = \frac{1}{f}$
11. Speed: $v = f\lambda$ or $v = \frac{\lambda}{T}$.
12. When a wave is reflected from a fixed end, the resulting wave will move back through the medium, but will be inverted. When a wave is reflected from a free end, the waves are reflected, but not inverted.
13. Standing waves.

6.6 Exercises

1. A standing wave is formed when:
 - (a) a wave refracts due to changes in the properties of the medium
 - (b) a wave reflects off a canyon wall and is heard shortly after it is formed
 - (c) a wave refracts and reflects due to changes in the medium
 - (d) two identical waves moving different directions along the same medium interfere
2. How many nodes and anti-nodes are shown in the diagram?

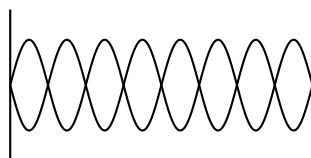

3. Draw a transverse wave that is reflected from a fixed end.
4. Draw a transverse wave that is reflected from a free end.
5. A wave travels along a string at a speed of $1,5 \text{ m}\cdot\text{s}^{-1}$. If the frequency of the source of the wave is 7,5 Hz, calculate:
 - (a) the wavelength of the wave
 - (b) the period of the wave

Chapter 7

Geometrical Optics - Grade 10

7.1 Introduction

You are indoors on a sunny day. A beam of sunlight through a window lights up a section of the floor. How would you draw this sunbeam? You might draw a series of parallel lines showing the path of the sunlight from the window to the floor. This is not exactly accurate – no matter how hard you look, you will not find unique lines of light in the sunbeam! However, this is a good way to draw light. It is also a good way to model light geometrically, as we will see in this chapter.

We will call these narrow, imaginary lines of light **light rays**. Since light is an electromagnetic wave, you could think of a light ray as the path of a point on the crest of a wave. Or, you could think of a light ray as the path taken by a miniscule particle that carries light. We will always draw them the same way: as straight lines between objects, images, and optical devices.

We can use light rays to model mirrors, lenses, telescopes, microscopes, and prisms. The study of how light interacts with materials is **optics**. When dealing with light rays, we are usually interested in the shape of a material and the angles at which light rays hit it. From these angles, we can work out, for example, the distance between an object and its reflection. We therefore refer to this kind of optics as **geometrical optics**.

7.2 Light Rays

In physics we use the idea of a *light ray* to indicate the direction that light travels. Light rays are lines with arrows and are used to show the path that light travels. In Figure 7.1, the light rays from the object enters the eye and the eye sees the object.

The most important thing to remember is that we can only see an object when light from the object enters our eyes. The object must be a source of light (for example a light bulb) or else it must reflect light from a source (for example the moon), and the reflected light enters our eyes.



Important: We cannot see an object unless light from that object enters our eyes.



Definition: Light ray

Light rays are straight lines with arrows to show the path of light.



Important: Light rays are not real. They are merely used to show the path that light travels.

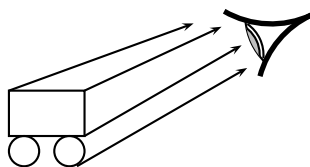

Figure 7.1: We can only see an object when light from that object enters our eyes. We draw light as lines with arrows to show the direction the light travels. When the light travels from the object to the eye, the eye can see the object.

Activity :: Investigation : Light travels in straight lines

Apparatus:

You will need a candle, matches and three sheets of paper.

Method:

1. Make a small hole in the middle of each of the three sheets of paper.
2. Light the candle.
3. Look at the burning candle through the hole in the first sheet of paper.
4. Place the second sheet of paper between you and the candle so that you can still see the candle through the holes.
5. Now do the same with the third sheet so that you can still see the candle. The sheets of paper must not touch each other.

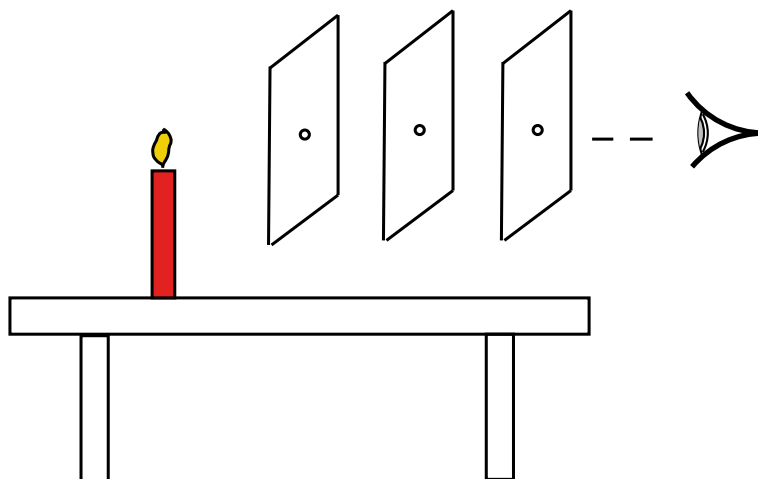

Figure 7.2: Light travels in straight lines

6. What do you notice about the holes in the paper?

Conclusions:

In the investigation you will notice that the holes in the paper need to be in a straight line. This shows that light travels in a straight line. We cannot see around corners. This also proves that light does not bend around a corner, but travels straight.

Activity :: Investigation : Light travels in straight lines

On a sunny day, stand outside and look at something in the distance, for example a tree, a flower or a car. From what we have learnt, we can see the tree, flower or car because light from the object is entering our eye. Now take a sheet of paper and hold it about 20 cm in front of your face. Can you still see the tree, flower or car? Why not?

Figure 7.3 shows that a sheet of paper in front of your eye prevents light rays from reaching your eye.

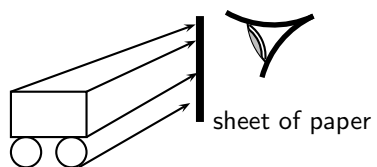
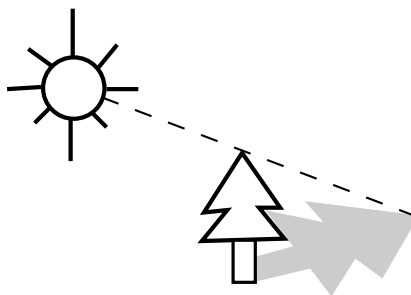

Figure 7.3: The sheet of paper prevents the light rays from reaching the eye, and the eye cannot see the object.

7.2.1 Shadows

Objects cast shadows when light shines on them. This is more evidence that light travels in straight lines. The picture below shows how shadows are formed.



7.2.2 Ray Diagrams

A ray diagram is a drawing that shows the path of light rays. Light rays are drawn using straight lines and arrow heads. The figure below shows some examples of ray diagrams.

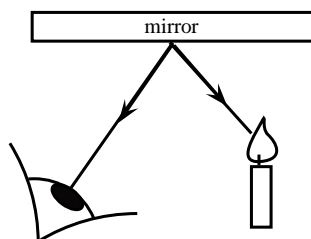
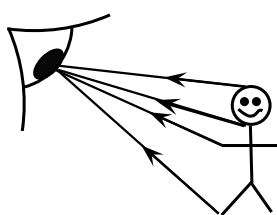



Exercise: Light Rays

1. Are light rays real? Explain.
2. Give evidence to support the statement: "Light travels in straight lines". Draw a ray diagram to prove this.
3. You are looking at a burning candle. Draw the path of light that enables you to see that candle.

7.3 Reflection

When you smile into a mirror, you see your own face smiling back at you. This is caused by the reflection of light rays on the mirror. Reflection occurs when a light ray bounces off a surface.

7.3.1 Terminology

In Chapters 5 and 6 we saw that when a pulse or wave strikes a surface it is *reflected*. This means that waves bounce off things. Sound waves bounce off walls, light waves bounce off mirrors, radar waves bounce off aeroplanes and it can explain how bats can fly at night and avoid things as thin as telephone wires. The phenomenon of reflection is a very important and useful one.

We will use the following terminology. The incoming light ray is called the **incident ray**. The light ray moving away from the surface is the **reflected ray**. The most important characteristic of these rays is their angles in relation to the reflecting surface. These angles are measured with respect to the normal of the surface. The **normal** is an imaginary line perpendicular to the surface. The **angle of incidence**, θ_i is measured between the incident ray and the surface normal. The **angle of reflection**, θ_r is measured between the reflected ray and the surface normal. This is shown in Figure 7.4.

When a ray of light is reflected, the reflected ray lies in the same plane as the incident ray and the normal. This plane is called the **plane of incidence** and is shown in Figure 7.5.

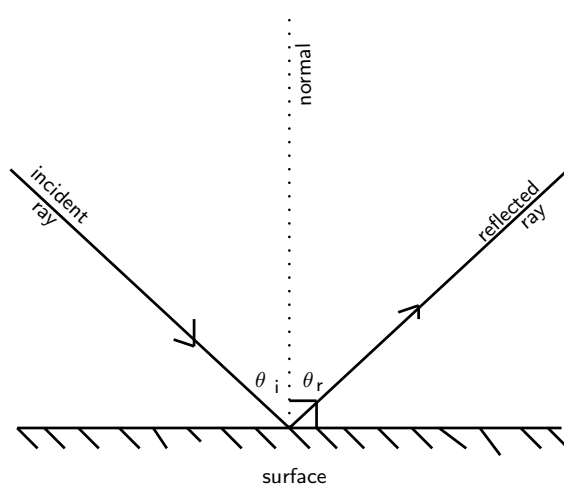

Figure 7.4: The angles of incidence and reflection are measured with respect to the surface normal.

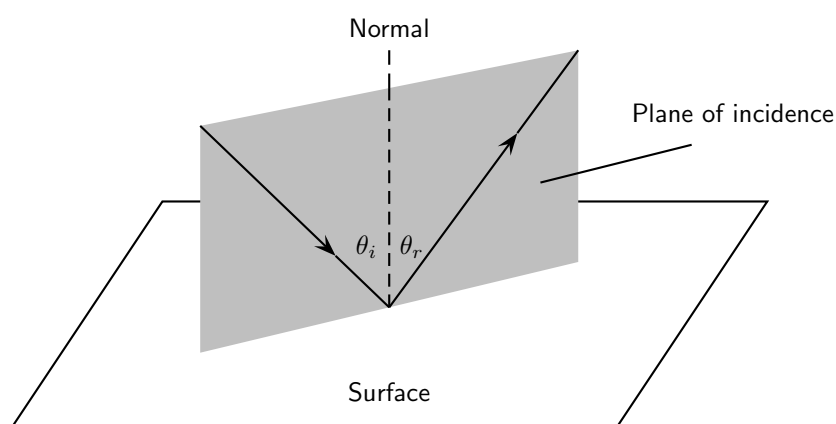

Figure 7.5: The plane of incidence is the plane including the incident ray, reflected ray, and the surface normal.

7.3.2 Law of Reflection

The **Law of Reflection** states that the angles of incidence and reflection are always equal and that the reflected ray always lies in the plane of incidence.

**Definition: Law of Reflection**

The Law of Reflection states that the angle of incidence is equal to the angle of reflection.

$$\theta_i = \theta_r$$

The simplest example of the law of incidence is if the angle of incidence is 0° . In this case, the angle of reflection is also 0° . You see this when you look straight into a mirror.

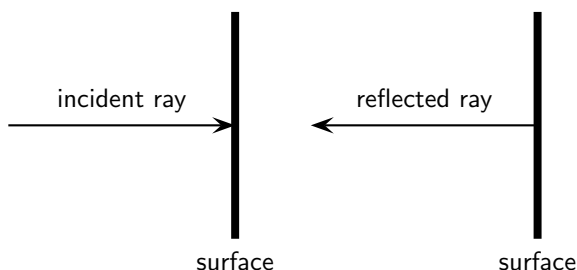

Figure 7.6: When a wave strikes a surface at right angles to the surface, then the wave is reflected directly back.

If the angle of incidence is not 0° , then the angle of reflection is also not 0° . For example, if a light strikes a surface at 60° to the surface normal, then the angle that the reflected ray makes with the surface normal is also 60° as shown in Figure 7.7.

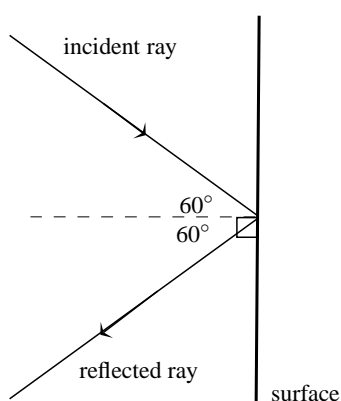

Figure 7.7: Ray diagram showing angle of incidence and angle of reflection. The Law of Reflection states that when a light ray reflects off a surface, the angle of reflection θ_r is the same as the angle of incidence θ_i .

**Worked Example 31: Law of Reflection**

Question: An incident ray strikes a smooth reflective surface at an angle of 33° to the surface normal. Calculate the angle of reflection.

Answer

Step 1 : Determine what is given and what is required

We are given the angle between the incident ray and the surface normal. This is the angle of incidence.

We are required to calculate the angle of reflection.

Step 2 : Determine how to approach the problem

We can use the Law of Reflection, which states that the angle of incidence is equal to the angle of reflection.

Step 3 : Calculate the angle of reflection

We are given the angle of incidence to be 33° . Therefore, the angle of reflection is also 33° .

7.3.3 Types of Reflection

The Law of Reflection is true for any surface. Does this mean that when parallel rays approach a surface, the reflected rays will also be parallel? This depends on the texture of the reflecting surface.

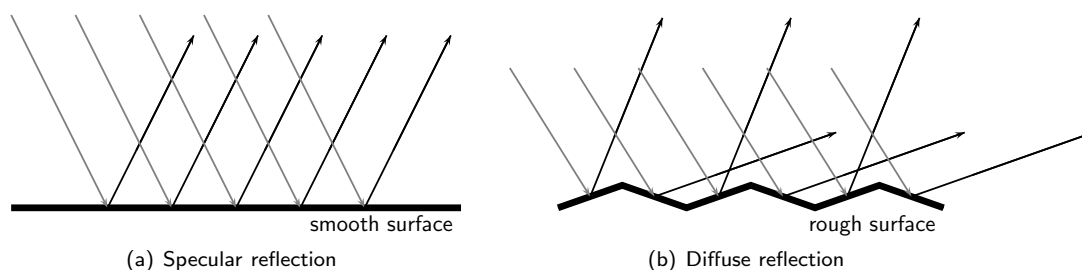

Figure 7.8: Specular and diffuse reflection.

Specular Reflection

Figure 7.8(a) shows a surface that is flat and even. Parallel incident light rays hit the smooth surface and parallel reflected light rays leave the surface. This type of reflection is called **specular reflection**. Specular reflection occurs when rays are reflected from a smooth, shiny surface. The normal to the surface is the same at every point on the surface. Parallel incident rays become parallel reflected rays. When you look in a mirror, the image you see is formed by specular reflection.

Diffuse Reflection

Figure 7.8(b) shows a surface with bumps and curves. When multiple rays hit this uneven surface, **diffuse reflection** occurs. The incident rays are parallel but the reflected rays are not. Each point on the surface has a different normal. This means the angle of incidence is different at each point. Then according to the Law of Reflection, each angle of reflection is different. Diffuse reflection occurs when light rays are reflected from bumpy surfaces. You can still see a reflection as long as the surface is not too bumpy. Diffuse reflection enables us to see all objects that are not sources of light.

Activity :: Experiment : Specular and Diffuse Reflection

A bouncing ball can be used to demonstrate the basic difference between specular and diffuse reflection.

Aim:

To demonstrate and compare specular and diffuse reflection.

Apparatus:

You will need:

1. a small ball (a tennis ball or a table tennis ball is perfect)
2. a smooth surface, like the floor inside the classroom
3. a very rough surface, like a rocky piece of ground

Method:

1. Bounce the ball on the smooth floor and observe what happens.
2. Bounce the ball on the rough ground floor and observe what happens.
3. What do you observe?

4. What is the difference between the two surfaces?

Conclusions:

You should have seen that the ball bounces (is reflected off the floor) in a predictable manner off the smooth floor, but bounces unpredictably on the rough ground.

The ball can be seen to be a ray of light and the floor or ground is the reflecting surface. For specular reflection (smooth surface), the ball bounces predictably. For diffuse reflection (rough surface), the ball bounces unpredictably.



Exercise: Reflection

1. The diagram shows a curved surface. Draw normals to the surface at the marked points.

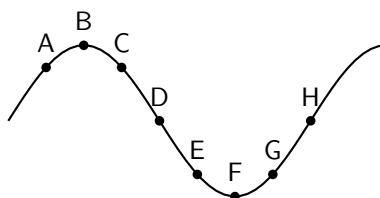

2. In the diagram, label the following:
- normal
 - angle of incidence
 - angle of reflection
 - incident ray
 - reflected ray

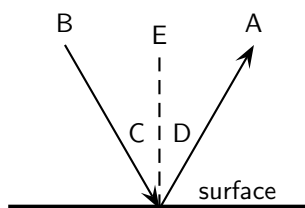

3. State the Law of Reflection. Draw a diagram, label the appropriate angles and write a mathematical expression for the Law of Reflection.
4. Draw a ray diagram to show the relationship between the angle of incidence and the angle of reflection.
5. The diagram shows an incident ray I . Which of the other 5 rays (A, B, C, D, E) best represents the reflected ray of I ?

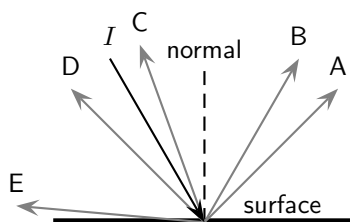

6. A ray of light strikes a surface at 15° to the surface normal. Draw a ray diagram showing the incident ray, reflected ray and surface normal. Calculate the angles of incidence and reflection and fill them in on your diagram.

7. A ray of light leaves a surface at 45° to the surface normal. Draw a ray diagram showing the incident ray, reflected ray and surface normal. Calculate the angles of incidence and reflection and fill them in on your diagram.
8. A ray of light strikes a surface at 25° to the surface. Draw a ray diagram showing the incident ray, reflected ray and surface normal. Calculate the angles of incidence and reflection and fill them in on your diagram.
9. A ray of light leaves a surface at 65° to the surface. Draw a ray diagram showing the incident ray, reflected ray and surface normal. Calculate the angles of incidence and reflection and fill them in on your diagram.
10. If the incident ray, the reflected ray and the surface normal do not fall on the same plane, will the angle of incidence equal the angle of reflection?
11. Explain the difference between specular and diffuse reflection.
12. We see an object when the light that is reflected by the object enters our eyes. Do you think the reflection by most objects is specular reflection or diffuse reflection? Explain.
13. A beam of light (for example from a torch) is generally not visible at night, as it travels through air. Try this for yourself. However, if you shine the torch through dust, the beam is visible. Explain why this happens.
14. If a torch beam is shone across a classroom, only students in the direct line of the beam would be able to see that the torch is shining. However, if the beam strikes a wall, the entire class will be able to see the spot made by the beam on the wall. Explain why this happens.
15. A scientist looking into a flat mirror hung perpendicular to the floor cannot see her feet but she can see the hem of her lab coat. Draw a ray diagram to help explain the answers to the following questions:
 - (a) Will she be able to see her feet if she backs away from the mirror?
 - (b) What if she moves towards the mirror?

7.4 Refraction

In the previous sections we studied light reflecting off various surfaces. What happens when light passes *through* a medium? Like all waves, the speed of light is dependent on the medium in which it is travelling. When light moves from one medium into another (for example, from air to glass), the speed of light changes. The effect is that the light ray passing into a new medium is **refracted**, or bent. Refraction is therefore the bending of light as it moves from one optical medium to another.



Definition: Refraction

Refraction is the bending of light that occurs because light travels at different speeds in different materials.

When light travels from one medium to another, it will be bent away from its original path. When it travels from an optically dense medium like water or glass to a less dense medium like air, it will be refracted away from the normal (Figure 7.9). Whereas, if it travels from a less dense medium to a denser one, it will be refracted towards the normal (Figure 7.10).

Just as we defined an angle of reflection in the previous section, we can similarly define an angle of refraction as the angle between the surface normal and the refracted ray. This is shown in Figure 7.11.

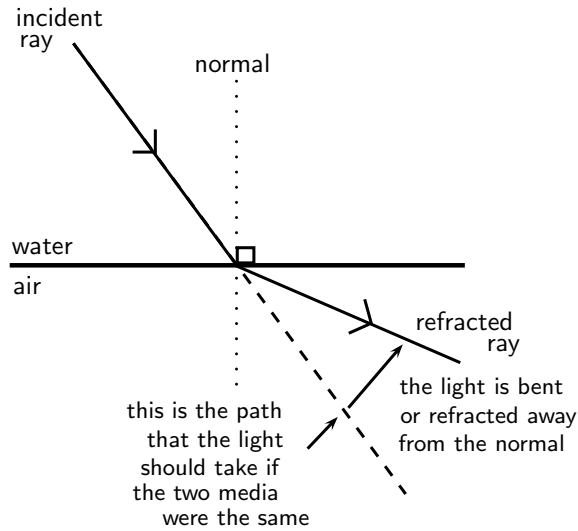

Figure 7.9: Light is moving from an optically dense medium to an optically less dense medium. Light is refracted away from the normal.

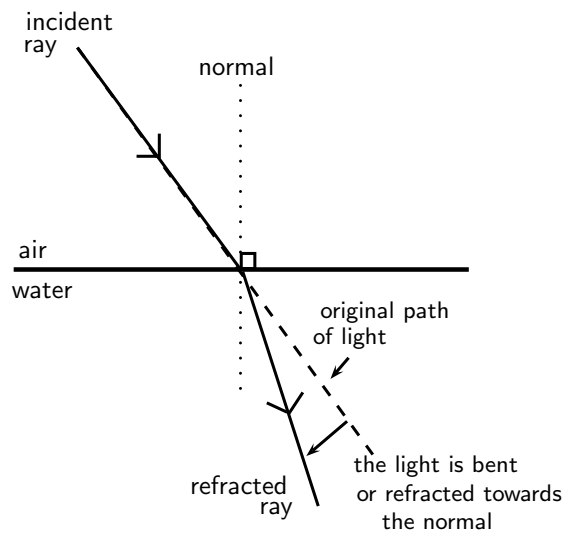

Figure 7.10: Light is moving from an optically less dense medium to an optically denser medium. Light is refracted towards the normal.

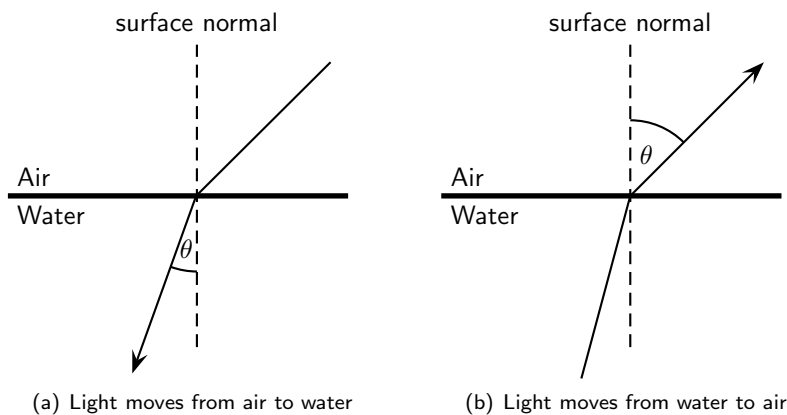

Figure 7.11: Light moving from one medium to another bends towards or away from the surface normal. The angle of refraction θ is shown.

7.4.1 Refractive Index

Which is easier to travel through, air or water? People usually travel faster through air. So does light! The speed of light and therefore the degree of bending of the light depends on the *refractive index* of material through which the light passes. The refractive index (symbol n) is the ratio of the speed of light in a vacuum to its speed in the material. You can think of the refractive index as a measure of how difficult it is for light to get through a material.



Definition: Refractive Index

The refractive index of a material is the ratio of the speed of light in a vacuum to its speed in the medium.

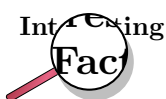

The symbol c is used to represent the speed of light in a vacuum.

$$c = 299\,792\,485 \text{ m} \cdot \text{s}^{-1}$$

For purposes of calculation, we use $3 \times 10^8 \text{ m} \cdot \text{s}^{-1}$. A vacuum is a region with no matter in it, not even air. However, the speed of light in air is very close to that in a vacuum.



Definition: Refractive Index

The refractive index (symbol n) of a material is the ratio of the speed of light in a vacuum to its speed in the material and gives an indication of how difficult it is for light to get through the material.

$$n = \frac{c}{v}$$

where

- $n =$ refractive index (no unit)
- $c =$ speed of light in a vacuum ($3,00 \times 10^8 \text{ m} \cdot \text{s}^{-1}$)
- $v =$ speed of light in a given medium ($\text{m} \cdot \text{s}^{-1}$)



Extension: Refractive Index and Speed of Light

Using

$$n = \frac{c}{v}$$

we can also examine how the speed of light changes in different media, because the speed of light in a vacuum (c) is constant.

If the refractive index n increases, the speed of light in the material v must decrease. Light therefore travels slowly through materials of high n .

Table 7.4.1 shows refractive indices for various materials. Light travels slower in any material than it does in a vacuum, so all values for n are greater than 1.

7.4.2 Snell's Law

Now that we know that the degree of bending, or the angle of refraction, is dependent on the refractive index of a medium, how do we calculate the angle of refraction?

The angles of incidence and refraction when light travels from one medium to another can be calculated using Snell's Law.

Medium	Refractive Index
Vacuum	1
Helium	1,000036
Air*	1,0002926
Carbon dioxide	1,00045
Water: Ice	1,31
Water: Liquid (20°C)	1,333
Acetone	1,36
Ethyl Alcohol (Ethanol)	1,36
Sugar solution (30%)	1,38
Fused quartz	1,46
Glycerine	1,4729
Sugar solution (80%)	1,49
Rock salt	1,516
Crown Glass	1,52
Sodium chloride	1,54
Polystyrene	1,55 to 1,59
Bromine	1,661
Sapphire	1,77
Glass (typical)	1,5 to 1,9
Cubic zirconia	2,15 to 2,18
Diamond	2,419
Silicon	4,01

Table 7.1: Refractive indices of some materials. n_{air} is calculated at STP and all values are determined for yellow sodium light which has a wavelength of 589,3 nm.



Definition: Snell's Law

$$n_1 \sin \theta_1 = n_2 \sin \theta_2$$

where

n_1 = Refractive index of material 1

n_2 = Refractive index of material 2

θ_1 = Angle of incidence

θ_2 = Angle of refraction

Remember that angles of incidence and refraction are measured from the normal, which is an imaginary line perpendicular to the surface.

Suppose we have two media with refractive indices n_1 and n_2 . A light ray is incident on the surface between these materials with an **angle of incidence** θ_1 . The refracted ray that passes through the second medium will have an **angle of refraction** θ_2 .



Worked Example 32: Using Snell's Law

Question: A light ray with an angle of incidence of 35° passes from water to air. Find the angle of refraction using Snell's Law and Table 7.4.1. Discuss the meaning of your answer.

Answer

Step 1 : Determine the refractive indices of water and air

From Table 7.4.1, the refractive index is 1,333 for water and about 1 for air. We know the angle of incidence, so we are ready to use Snell's Law.

Step 2 : Substitute values

According to Snell's Law:

$$\begin{aligned}n_1 \sin \theta_1 &= n_2 \sin \theta_2 \\1,33 \sin 35^\circ &= 1 \sin \theta_2 \\ \sin \theta_2 &= 0,763 \\ \theta_2 &= 49,7^\circ.\end{aligned}$$

Step 3 : Discuss the answer

The light ray passes from a medium of high refractive index to one of low refractive index. Therefore, the light ray is bent away from the normal.



Worked Example 33: Using Snell's Law

Question: A light ray passes from water to diamond with an angle of incidence of 75° . Calculate the angle of refraction. Discuss the meaning of your answer.

Answer

Step 1 : Determine the refractive indices of water and air

From Table 7.4.1, the refractive index is 1,333 for water and 2,42 for diamond. We know the angle of incidence, so we are ready to use Snell's Law.

Step 2 : Substitute values and solve

According to Snell's Law:

$$\begin{aligned}n_1 \sin \theta_1 &= n_2 \sin \theta_2 \\1,33 \sin 75^\circ &= 2,42 \sin \theta_2 \\ \sin \theta_2 &= 0,531 \\ \theta_2 &= 32,1^\circ.\end{aligned}$$

Step 3 : Discuss the answer

The light ray passes from a medium of low refractive index to one of high refractive index. Therefore, the light ray is bent towards the normal.

If

$$n_2 > n_1$$

then from Snell's Law,

$$\sin \theta_1 > \sin \theta_2.$$

For angles smaller than 90° , $\sin \theta$ increases as θ increases. Therefore,

$$\theta_1 > \theta_2.$$

This means that the angle of incidence is greater than the angle of refraction and the light ray is bent toward the normal.

Similarly, if

$$n_2 < n_1$$

then from Snell's Law,

$$\sin \theta_1 < \sin \theta_2.$$

For angles smaller than 90° , $\sin \theta$ increases as θ increases. Therefore,

$$\theta_1 < \theta_2.$$

This means that the angle of incidence is less than the angle of refraction and the light ray is away toward the normal.

Both these situations can be seen in Figure 7.12.

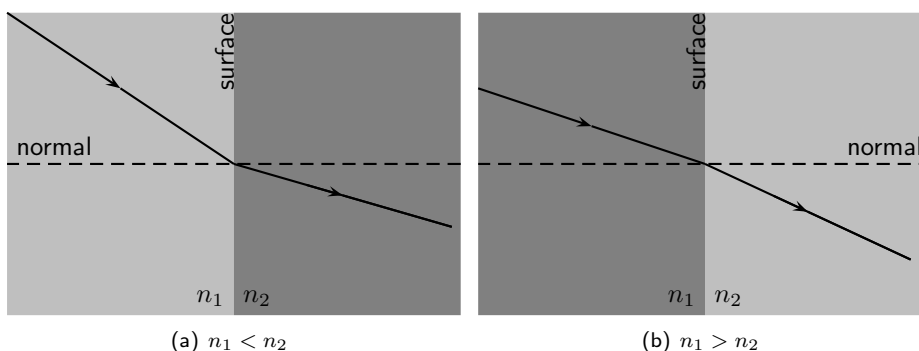

Figure 7.12: Refraction of two light rays. (a) A ray travels from a medium of low refractive index to one of high refractive index. The ray is bent towards the normal. (b) A ray travels from a medium with a high refractive index to one with a low refractive index. The ray is bent away from the normal.

What happens to a ray that lies along the normal line? In this case, the angle of incidence is 0° and

$$\begin{aligned}\sin \theta_2 &= \frac{n_1}{n_2} \sin \theta_1 \\ &= 0 \\ \therefore \theta_2 &= 0.\end{aligned}$$

This shows that if the light ray is incident at 0° , then the angle of refraction is also 0° . The ray passes through the surface unchanged, i.e. no refraction occurs.

Activity :: Investigation : Snell's Law 1

The angles of incidence and refraction were measured in five unknown media and recorded in the table below. Use your knowledge about Snell's Law to identify each of the unknown media A - E. Use Table 7.4.1 to help you.

Medium 1	n_1	θ_1	θ_2	n_2	Unknown Medium
Air	1,000036	38	11,6	?	A
Air	1,000036	65	38,4	?	B
Vacuum	1	44	0,419	?	C
Air	1,000036	15	29,3	?	D
Vacuum	1	20	36,9	?	E

Activity :: Investigation : Snell's Law 2

Zingi and Tumi performed an investigation to identify an unknown liquid. They shone a beam of light into the unknown liquid, varying the angle of incidence and recording the angle of refraction. Their results are recorded in the following table:

Angle of Incidence	Angle of Refraction
0,0°	0,00°
5,0°	3,76°
10,0°	7,50°
15,0°	11,2°
20,0°	14,9°
25,0°	18,5°
30,0°	22,1°
35,0°	25,5°
40,0°	28,9°
45,0°	32,1°
50,0°	35,2°
55,0°	38,0°
60,0°	40,6°
65,0°	43,0°
70,0°	?
75,0°	?
80,0°	?
85,0°	?

1. Write down an aim for the investigation.
2. Make a list of all the apparatus they used.
3. Identify the unknown liquid.
4. Predict what the angle of refraction will be for 70°, 75°, 80° and 85°.

7.4.3 Apparent Depth

Imagine a coin on the bottom of a shallow pool of water. If you reach for the coin, you will miss it because the light rays from the coin are refracted at the water's surface.

Consider a light ray that travels from an underwater object to your eye. The ray is refracted at the water surface and then reaches your eye. Your eye does not know Snell's Law; it assumes light rays travel in straight lines. Your eye therefore sees the image of the coin shallower location. This shallower location is known as the *apparent depth*.

The refractive index of a medium can also be expressed as

$$n = \frac{\text{real depth}}{\text{apparent depth}}$$

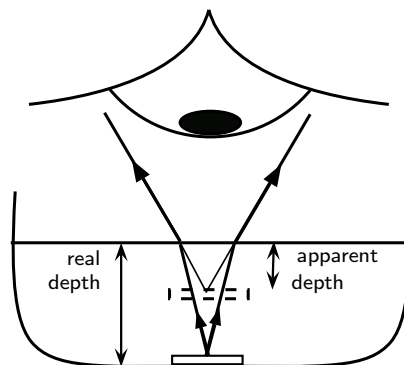

Worked Example 34: Apparent Depth 1



Question: A coin is placed at the bottom of a 40 cm deep pond. The refractive index for water is 1,33. How deep does the coin appear to be?

Answer

Step 1 : Identify what is given and what is asked

$$n = 1,33$$

$$\text{real depth} = 40 \text{ cm}$$

$$\text{apparent depth} = ?$$

Step 2 : Substitute values and find answer

$$n = \frac{\text{real depth}}{\text{apparent depth}}$$

$$1,33 = \frac{40}{x}$$

$$x = \frac{40}{1,33} = 30,08 \text{ cm}$$

The coin appears to be 30,08 cm deep.



Worked Example 35: Apparent Depth 2

Question: A R1 coin appears to be 7 cm deep in a colourless liquid. The depth of the liquid is 10,43 cm.

1. Determine the refractive index of the liquid.
2. Identify the liquid.

Answer

Step 1 : Identify what is given and what is asked

$$\text{real depth} = 7 \text{ cm}$$

$$\text{apparent depth} = 10,43 \text{ cm}$$

$$n = ?$$

Identify the liquid.

Step 2 : Calculate refractive index

$$n = \frac{\text{real depth}}{\text{apparent depth}}$$

$$= \frac{10,43}{7}$$

$$= 1,49$$

Step 3 : Identify the liquid

Use Table 7.4.1. The liquid is an 80% sugar solution.



Exercise: Refraction

1. Explain refraction in terms of a change of wave speed in different media.
2. In the diagram, label the following:
 - (a) angle of incidence
 - (b) angle of refraction

- (c) incident ray
- (d) refracted ray
- (e) normal

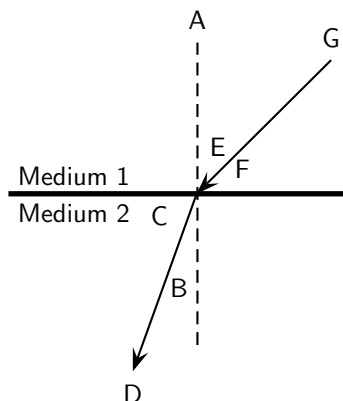

3. What is *the angle of refraction*?
4. Describe what is meant by *the refractive index of a medium*.
5. State Snell's Law.
6. In the diagram, a ray of light strikes the interface between two media.

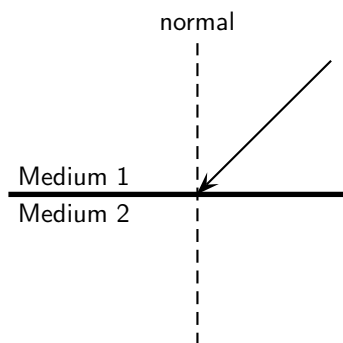

Draw what the refracted ray would look like if:

- (a) medium 1 had a higher refractive index than medium 2.
 - (b) medium 1 had a lower refractive index than medium 2.
7. Light travels from a region of glass into a region of glycerine, making an angle of incidence of 40° .
 - (a) Describe the path of the light as it moves into the glycerine.
 - (b) Calculate the angle of refraction.
 8. A ray of light travels from silicon to water. If the ray of light in the water makes an angle of 69° to the surface normal, what is the angle of incidence in the silicon?
 9. Light travels from a medium with $n = 1,25$ into a medium of $n = 1,34$, at an angle of 27° from the interface normal.
 - (a) What happens to the speed of the light? Does it increase, decrease, or remain the same?
 - (b) What happens to the wavelength of the light? Does it increase, decrease, or remain the same?
 - (c) Does the light bend towards the normal, away from the normal, or not at all?
 10. Light travels from a medium with $n = 1,63$ into a medium of $n = 1,42$.
 - (a) What happens to the speed of the light? Does it increase, decrease, or remain the same?
 - (b) What happens to the wavelength of the light? Does it increase, decrease, or remain the same?

- (c) Does the light bend towards the normal, away from the normal, or not at all?
- Light is incident on a glass prism. The prism is surrounded by air. The angle of incidence is 23° . Calculate the angle of reflection and the angle of refraction.
 - Light is refracted at the interface between air and an unknown medium. If the angle of incidence is 53° and the angle of refraction is 37° , calculate the refractive index of the unknown, second medium.
 - A coin is placed in a bowl of acetone ($n = 1,36$). The coin appears to be 10 cm deep. What is the depth of the acetone?
 - A dot is drawn on a piece of paper and a glass prism placed on the dot according to the diagram.

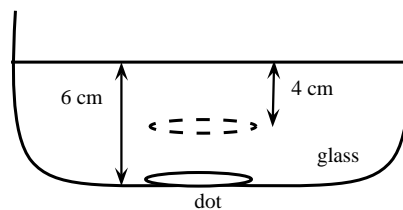

- Use the information supplied to determine the refractive index of glass.
 - Draw a ray diagram to explain how the image of the dot is above where the dot really is.
- Light is refracted at the interface between a medium of refractive index 1,5 and a second medium of refractive index 2,1. If the angle of incidence is 45° , calculate the angle of refraction.
 - A ray of light strikes the interface between air and diamond. If the incident ray makes an angle of 30° with the interface, calculate the angle made by the refracted ray with the interface.
 - Challenge Question:** What values of n are physically impossible to achieve? Explain your answer. The values provide the limits of possible refractive indices.
 - Challenge Question:** You have been given a glass beaker full of an unknown liquid. How would you identify what the liquid is? You have the following pieces of equipment available for the experiment: a laser, a protractor, a ruler, a pencil, and a reference guide containing optical properties of various liquids.

7.5 Mirrors

A mirror is a highly reflective surface. The most common mirrors are flat and are known as **plane mirrors**. Household mirrors are plane mirrors. They are made of a flat piece of glass with a thin layer of silver nitrate or aluminium on the back. However, other mirrors are curved and are either **convex mirrors** or are **concave mirrors**. The reflecting properties of all three types of mirrors will be discussed in this section.

7.5.1 Image Formation



Definition: Image

An image is a representation of an object formed by a mirror or lens. Light from the image is seen.

If you place a candle in front of a mirror, you now see two candles. The actual, physical candle is called the object and the picture you see in the mirror is called the image. The **object** is the source of the incident rays. The **image** is the picture that is formed by the reflected rays.

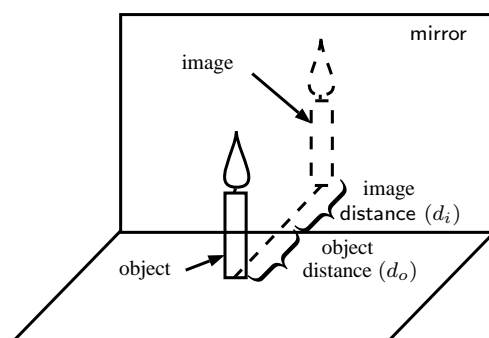

Figure 7.13: An object formed in a mirror is real and upright.

The object could be an actual source that emits light, such as a light bulb or a candle. More commonly, the object reflects light from another source. When you look at your face in the mirror, your face does not emit light. Instead, light from a light bulb or from the sun reflects off your face and then hits the mirror. However, in working with light rays, it is easiest to pretend the light is coming from the object.

An image formed by reflection may be real or virtual. A **real** image occurs when light rays actually intersect at the image. A real image is inverted, or upside down. A **virtual** image occurs when light rays do not actually meet at the image. Instead, you "see" the image because your eye projects light rays backward. You are fooled into seeing an image! A virtual image is erect, or right side up (upright).

You can tell the two types apart by putting a screen at the location of the image. A real image can be formed on the screen because the light rays actually meet there. A virtual image cannot be seen on a screen, since it is not really there.

To describe objects and images, we need to know their locations and their sizes. The distance from the mirror to the object is the **object distance**, d_o .

The distance from the mirror to the image is the **image distance**, d_i .

7.5.2 Plane Mirrors

Activity :: Investigation : Image formed by a mirror

1. Stand one step away from a large mirror
 2. What do you observe in the mirror? This is called your image.
 3. What size is your image? Bigger, smaller or the same size as you?
 4. How far is your image from you? How far is your image from the mirror?
 5. Is your image upright or upside down?
 6. Take one step backwards. What does your image do? How far are you away from your image?
 7. Lift your left arm. Which arm does your image lift?
-

When you look into a mirror, you see an *image* of yourself.

The image created in the mirror has the following properties:

1. The image is *virtual*.

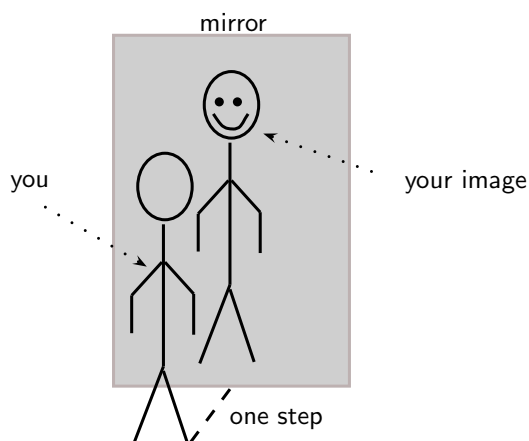

Figure 7.14: An image in a mirror is virtual, upright, the same size and laterally inverted.

2. The image is the same distance behind the mirror as the object is in front of the mirror.
3. The image is *laterally* inverted. This means that the image is inverted from side to side.
4. The image is the same size as the object.
5. The image is upright.

Virtual images are images formed in places where light does not really reach. Light does not really pass through the mirror to create the image; it only appears to an observer as though the light were coming from behind the mirror. Whenever a mirror creates an image which is virtual, the image will always be located behind the mirror where light does not really pass.



Definition: Virtual Image

A virtual image is upright, on the opposite side of the mirror as the object, and light does not actually reach it.

7.5.3 Ray Diagrams

We draw *ray diagrams* to predict the image that is formed by a plane mirror. A ray diagram is a geometrical picture that is used for analyzing the images formed by mirrors and lenses. We draw a few characteristic rays from the object to the mirror. We then follow ray-tracing rules to find the path of the rays and locate the image.

Important: A mirror obeys the Law of Reflection.

The ray diagram for the image formed by a plane mirror is the simplest possible ray diagram. Figure 7.15 shows an object placed in front of a plane mirror. It is convenient to have a central line that runs perpendicular to the mirror. This imaginary line is called the **principal axis**.

Important: Ray diagrams

The following should be remembered when drawing ray diagrams:

1. Objects are represented by arrows. The length of the arrow represents the height of the object.
2. If the arrow points upwards, then the object is described as upright or erect. If the arrow points downwards then the object is described as inverted.
3. If the object is real, then the arrow is drawn with a solid line. If the object is virtual, then the arrow is drawn with a dashed line.

Method: Ray Diagrams for Plane Mirrors

Ray diagrams are used to find the position and size and whether the image is real or virtual.

1. Draw the plane mirror as a straight line on a principal axis.

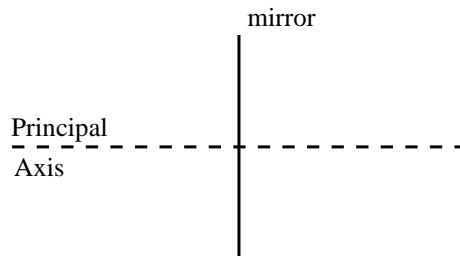

2. Draw the object as an arrow in front of the mirror.

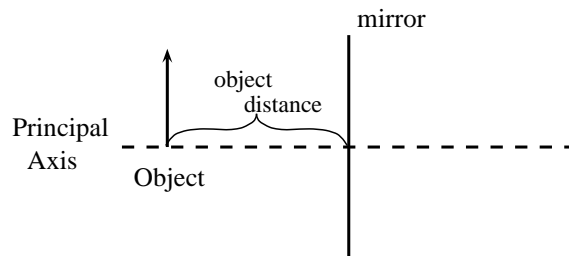

3. Draw the image of the object, by using the principle that the image is placed at the same distance behind the mirror that the object is in front of the mirror. The image size is also the same as the object size.

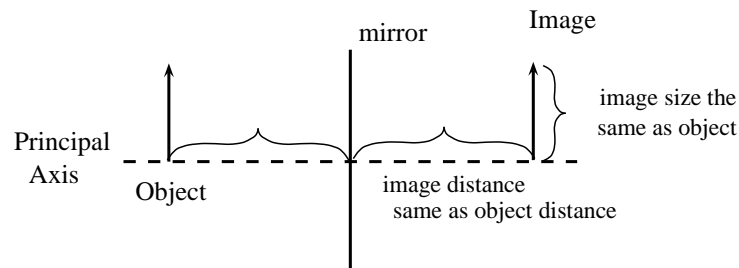

4. Place a dot at the point the eye is located.
5. Pick one point on the image and draw the reflected ray that travels to the eye as it sees this point. Remember to add an arrowhead.

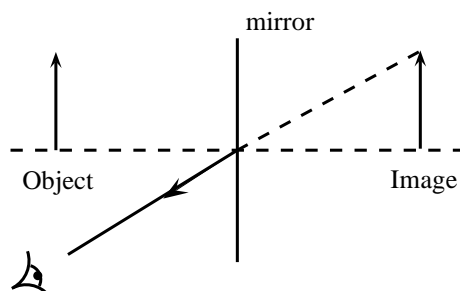

6. Draw the incident ray for light traveling from the corresponding point on the object to the mirror, such that the law of reflection is obeyed.

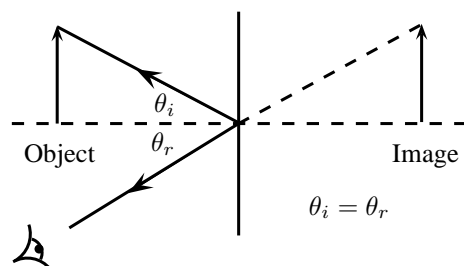

7. Continue for other extreme points on the object.

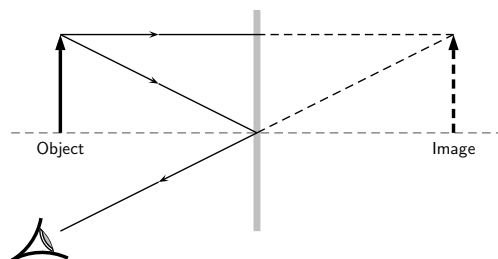

Figure 7.15: Ray diagram to predict the image formed by a plane mirror.

Suppose a light ray leaves the top of the object traveling parallel to the principal axis. The ray will hit the mirror at an angle of incidence of 0 degrees. We say that the ray hits the mirror *normally*. According to the law of reflection, the ray will be reflected at 0 degrees. The ray then bounces back in the same direction. We also project the ray back behind the mirror because this is what your eye does.

Another light ray leaves the top of the object and hits the mirror at its centre. This ray will be reflected at the same angle as its angle of incidence, as shown. If we project the ray backward behind the mirror, it will eventually cross the projection of the first ray we drew. We have found the location of the image! It is a virtual image since it appears in an area that light cannot actually reach (behind the mirror). You can see from the diagram that the image is erect and is the same size as the object. This is exactly as we expected.

We use a dashed line to indicate that the image is virtual.

7.5.4 Spherical Mirrors

The second class of mirrors that we will look at are spherical mirrors. These mirrors are called spherical mirrors because if you take a sphere and cut it as shown in Figure 7.16 and then polish the inside of one and the outside of the other, you will get a *concave mirror* and *convex mirror* as shown. These two mirrors will be studied in detail.

The centre of curvature is the point at the centre of the sphere and describes how big the sphere is.

7.5.5 Concave Mirrors

The first type of curved mirror we will study are concave mirrors. Concave mirrors have the shape shown in Figure 7.17. As with a plane mirror, the principal axis is a line that is perpendicular to the centre of the mirror.

If you think of light reflecting off a concave mirror, you will immediately see that things will look very different compared to a plane mirror. The easiest way to understand what will happen is to draw a ray diagram and work out where the images will form. Once we have done that it is easy to see what properties the image has.

First we need to define a very important characteristic of the mirror. We have seen that the centre of curvature is the centre of the sphere from which the mirror is cut. We then define that

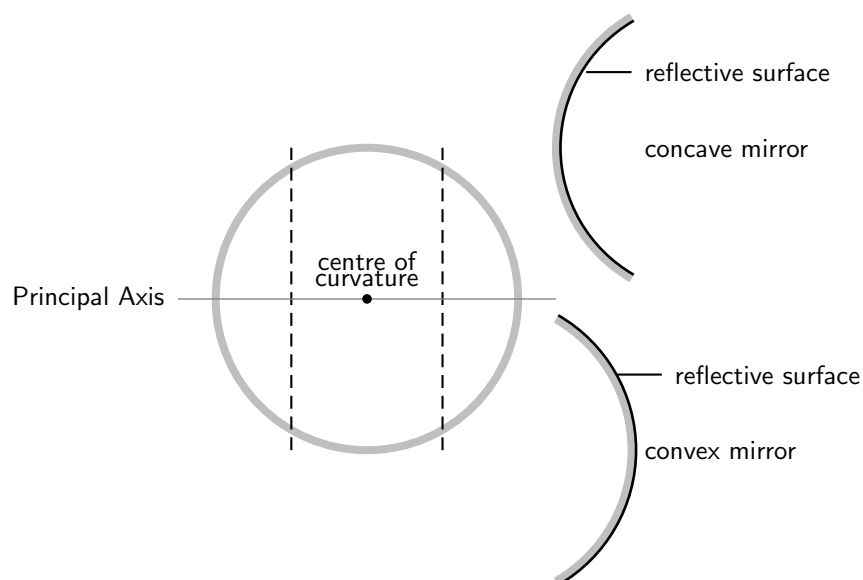

Figure 7.16: When a sphere is cut and then polished to a reflective surface on the inside a concave mirror is obtained. When the outside is polished to a reflective surface, a convex mirror is obtained.

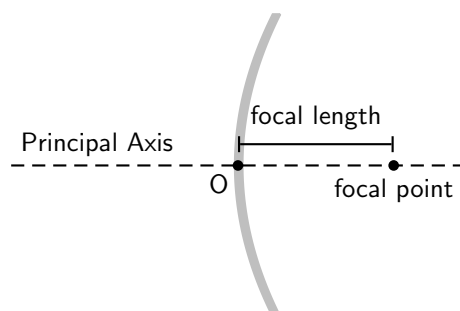

Figure 7.17: Concave mirror with principal axis.

a distance that is half-way between the centre of curvature and the mirror on the principal axis. This point is known as the *focal point* and the distance from the focal point to the mirror is known as the *focal length* (symbol f). Since the focal point is the midpoint of the line segment joining the vertex and the centre of curvature, the focal length would be one-half the radius of curvature. This fact can come in very handy, remember if you know one then you know the other!



Definition: Focal Point

The focal point of a mirror is the midpoint of a line segment joining the vertex and the centre of curvature. It is the position at which all parallel rays are focussed.

Why are we making such a big deal about this point we call the focal point? It has an important property we will use often. A ray parallel to the principal axis hitting the mirror will always be reflected through the focal point. The focal point is the position at which all parallel rays are *focussed*.

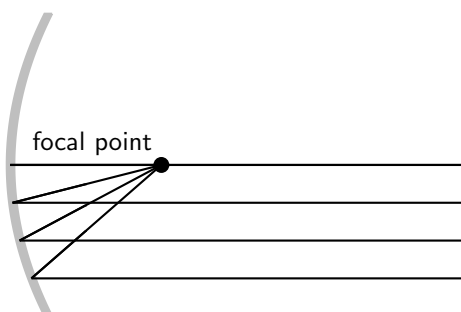

Figure 7.18: All light rays pass through the focal point.

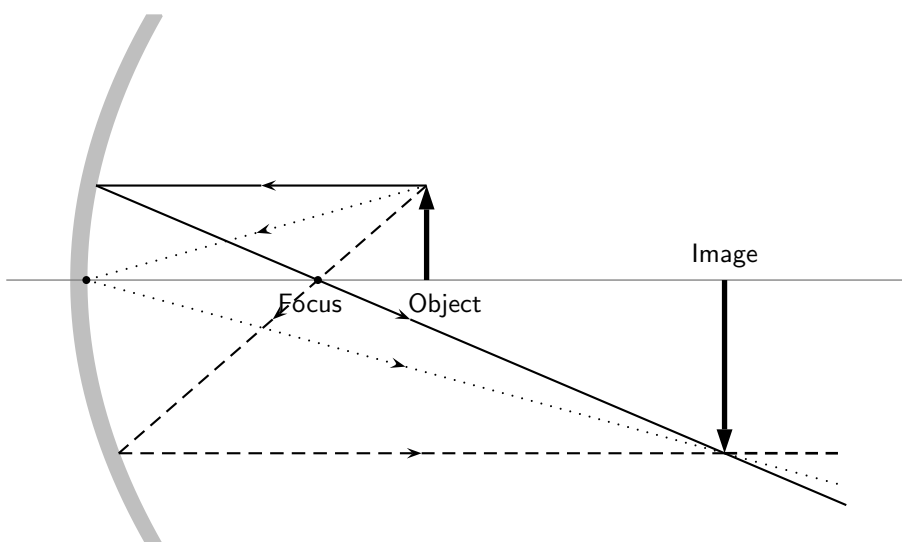

Figure 7.19: A concave mirror with three rays drawn to locate the image. Each incident ray is reflected according to the Law of Reflection. The intersection of the reflected rays gives the location of the image. Here the image is real and inverted.

From Figure 7.19, we see that the image created by a concave mirror is real and inverted, as compared to the virtual and erect image created by a plane mirror.

**Definition: Real Image**

A real image can be cast on a screen; it is inverted, and on the same side of the mirror as the object.

*Extension: Convergence*

A concave mirror is also known as a converging mirror. Light rays appear to converge to the focal point of a concave mirror.

7.5.6 Convex Mirrors

The second type of curved mirror we will study are convex mirrors. Convex mirrors have the shape shown in Figure 7.20. As with a plane mirror, the principal axis is a line that is perpendicular to the centre of the mirror.

We have defined the focal point as that point that is half-way along the principal axis between the centre of curvature and the mirror. Now for a convex mirror, this point is *behind* the mirror. A convex mirror has a *negative* focal length because the focal point is behind the mirror.

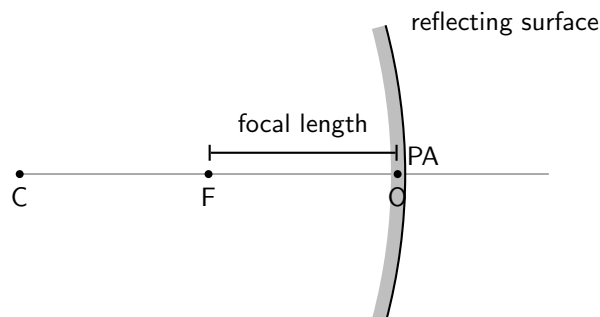

Figure 7.20: Convex mirror with principle axis, focal point (F) and centre of curvature (C). The centre of the mirror is the optical centre (O).

To determine what the image from a convex mirror looks like and where the image is located, we need to remember that a mirror obeys the laws of reflection and that light appears to come from the image. The image created by a convex mirror is shown in Figure 7.21.

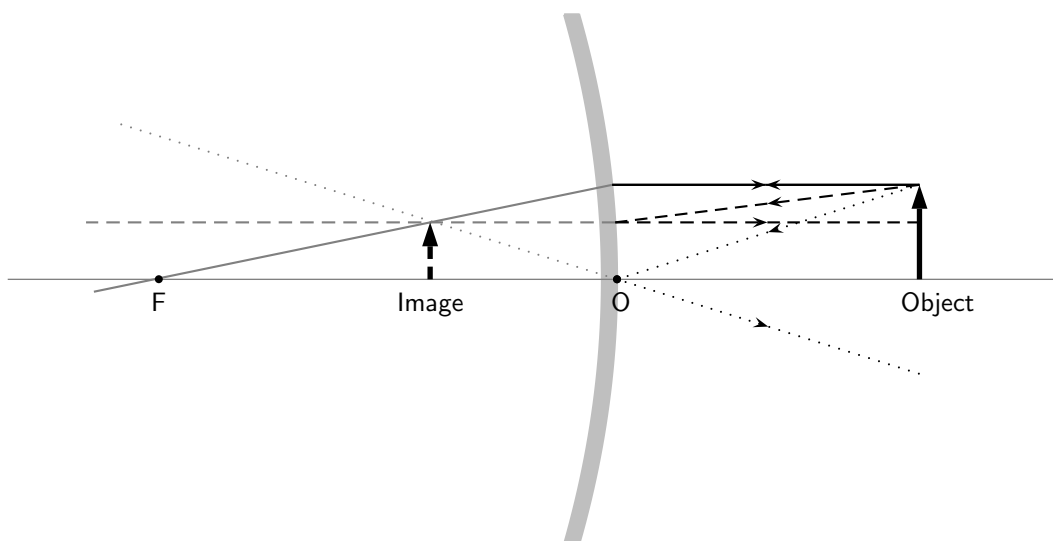

Figure 7.21: A convex mirror with three rays drawn to locate the image. Each incident ray is reflected according to the Law of Reflection. The reflected rays diverge. If the reflected rays are extended behind the mirror, then their intersection gives the location of the image behind the mirror. For a convex mirror, the image is virtual and upright.

From Figure 7.21, we see that the image created by a convex mirror is virtual and upright, as compared to the real and inverted image created by a concave mirror.



Extension: Divergence

A convex mirror is also known as a diverging mirror. Light rays appear to diverge from the focal point of a convex mirror.

7.5.7 Summary of Properties of Mirrors

The properties of mirrors are summarised in Table 7.2.

Table 7.2: Summary of properties of concave and convex mirrors.

Plane	Concave	Convex
–	converging	diverging
virtual image	real image	virtual image
upright	inverted	upright
image behind mirror	image in front of mirror	image behind mirror

7.5.8 Magnification

In Figures 7.19 and 7.21, the height of the object and image arrows were different. In any optical system where images are formed from objects, the ratio of the image height, h_i , to the object height, h_o is known as the magnification, m .

$$m = \frac{h_i}{h_o}$$

This is true for the mirror examples we showed above and will also be true for lenses, which will be introduced in the next sections. For a plane mirror, the height of the image is the same as the

height of the object, so the magnification is simply $m = \frac{h_i}{h_o} = 1$. If the magnification is greater than 1, the image is larger than the object and is said to be *magnified*. If the magnification is less than 1, the image is smaller than the object so the image is said to be *diminished*.



Worked Example 36: Magnification

Question: A concave mirror forms an image that is 4,8 cm high. The height of the object is 1,6 cm. Calculate the magnification of the mirror.

Answer

Step 1 : Identify what is given and what is asked.

Image height $h_i = 4,8$ cm

Object height $h_o = 1,6$ cm

Magnification $m = ?$

Step 2 : Substitute the values and calculate m.

$$\begin{aligned} m &= \frac{h_i}{h_o} \\ &= \frac{4,8}{1,6} \\ &= 3 \end{aligned}$$

The magnification is 3 times.



Exercise: Mirrors

- List 5 properties of a virtual image created by reflection from a plane mirror.
- What angle does the principal axis make with a plane mirror?
- Is the principal axis a normal to the surface of the plane mirror?
- Do the reflected rays that contribute to forming the image from a plane mirror obey the law of reflection?
- If a candle is placed 50 cm in front of a plane mirror, how far behind the plane mirror will the image be? Draw a ray diagram to show how the image is formed.
- If a stool 0,5 m high is placed 2 m in front of a plane mirror, how far behind the plane mirror will the image be and how high will the image be?
- If Susan stands 3 m in front of a plane mirror, how far from Susan will her image be located?
- Explain why ambulances have the word 'ambulance' reversed on the front bonnet of the car?
- Complete the diagram by filling in the missing lines to locate the image.

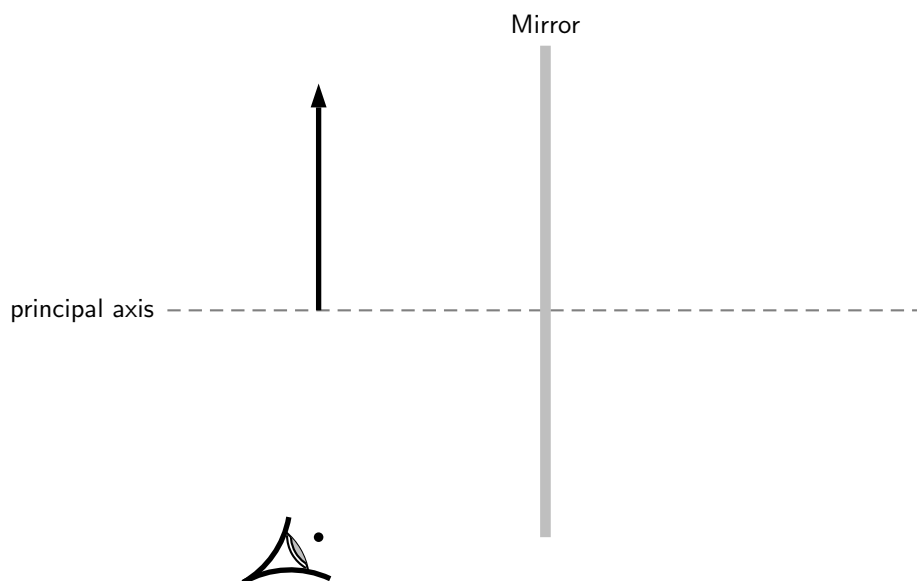

10. An object 2 cm high is placed 4 cm in front of a plane mirror. Draw a ray diagram, showing the object, the mirror and the position of the image.
11. The image of an object is located 5 cm behind a plane mirror. Draw a ray diagram, showing the image, the mirror and the position of the object.
12. How high must a mirror be so that you can see your whole body in it? Does it make a difference if you change the distance you stand in front of the mirror? Explain.
13. If 1-year old Tommy crawls towards a mirror at a rate of $0,3 \text{ m}\cdot\text{s}^{-1}$, at what speed will Tommy and his image approach each other?
14. Use a diagram to explain how light converges to the focal point of a concave mirror.
15. Use a diagram to explain how light diverges away from the focal point of a convex mirror.
16. An object 1 cm high is placed 4 cm from a concave mirror. If the focal length of the mirror is 2 cm, find the position and size of the image by means of a ray diagram. Is the image real or virtual?
17. An object 2 cm high is placed 4 cm from a convex mirror. If the focal length of the mirror is 4 cm, find the position and size of the image by means of a ray diagram. Is the image real or virtual?
18. Calculate the magnification for each of the mirrors in the previous two questions.

7.6 Total Internal Reflection and Fibre Optics

7.6.1 Total Internal Reflection

Activity :: Investigation : Total Internal Reflection

Work in groups of four. Each group will need a raybox (or torch) with slit, triangular glass prism and protractor. If you do not have a raybox, use a torch and stick two pieces of tape over the lens so that only a thin beam of light is visible.

Aim:

To investigate total internal reflection.

Method:

- Place the raybox next to the glass block so that the light shines right through without any refraction. See "Position 1" in diagram.

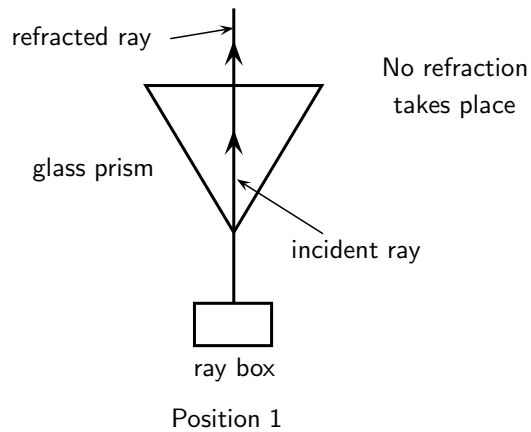

- Move the raybox such that the light is refracted by the glass. See "Position 2".

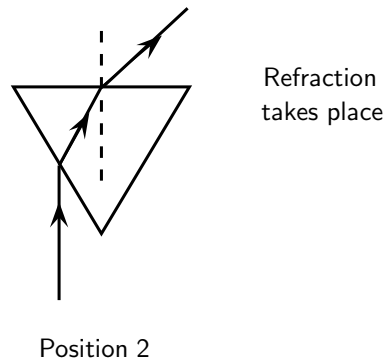

- Move the raybox further and observe what happens.

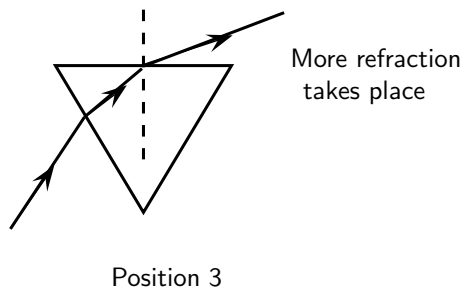

- Move the raybox until the refracted ray seems to disappear. See "Position 4". The angle of the incident light is called the critical angle.

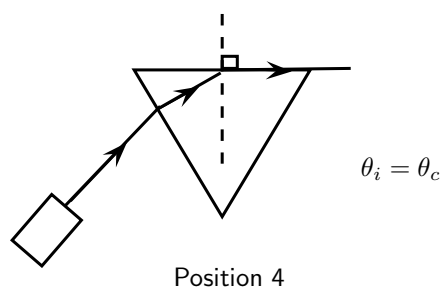

- Move the raybox further and observe what happens. See "Position 5". The light shines back into the glass block. This is called total internal reflection.

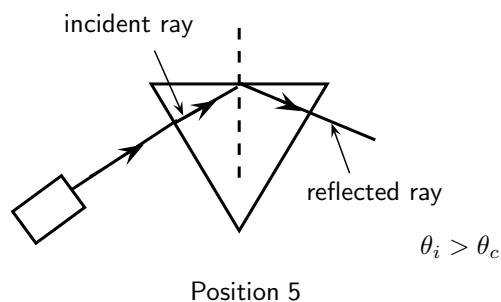

When we increase the angle of incidence, we reach a point where the angle of refraction is 90° and the refracted ray runs along the surface of the medium. This angle of incidence is called the critical angle.



Definition: Critical Angle

The critical angle is the angle of incidence where the angle of refraction is 90° . The light must shine from a dense to a less dense medium.

If the angle of incidence is bigger than this critical angle, the refracted ray will not emerge from the medium, but will be reflected back into the medium. This is called total internal reflection.

Total internal reflection takes place when

- light shines from an optically denser medium to an optically less dense medium.
- the angle of incidence is greater than the critical angle.



Definition: Total Internal Reflection

Total internal reflection takes place when light is reflected back into the medium because the angle of incidence is greater than the critical angle.

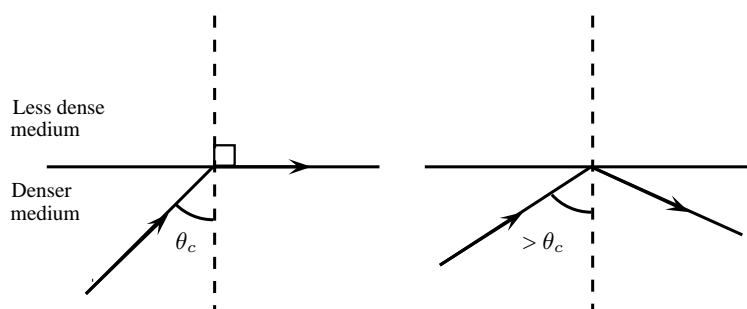

Figure 7.22: Diagrams to show the critical angle and total internal reflection.

Each medium has its own unique critical angle. For example, the critical angle for glass is 42° , and that of water is $48,8^\circ$. We can calculate the critical angle for any medium.

Calculating the Critical Angle

Now we shall learn how to derive the value of the critical angle for two given media. The process is fairly simple and involves just the use of Snell's Law that we have already studied. To recap, Snell's Law states:

$$n_1 \sin \theta_1 = n_2 \sin \theta_2$$

where n_1 is the refractive index of material 1, n_2 is the refractive index of material 2, θ_1 is the angle of incidence and θ_2 is the angle of refraction. For total internal reflection we know that the angle of incidence is the critical angle. So,

$$\theta_1 = \theta_c.$$

However, we also know that the angle of refraction at the critical angle is 90° . So we have:

$$\theta_2 = 90^\circ.$$

We can then write Snell's Law as:

$$n_1 \sin \theta_c = n_2 \sin 90^\circ$$

Solving for θ_c gives:

$$\begin{aligned} n_1 \sin \theta_c &= n_2 \sin 90^\circ \\ \sin \theta_c &= \frac{n_2}{n_1}(1) \\ \therefore \theta_c &= \sin^{-1}\left(\frac{n_2}{n_1}\right) \end{aligned}$$



Important: Take care that for total internal reflection the incident ray is always in the denser medium.



Worked Example 37: Critical Angle 1

Question: Given that the refractive indices of air and water are 1 and 1,33, respectively, find the critical angle.

Answer

Step 1 : Determine how to approach the problem

We know that the critical angle is given by:

$$\theta_c = \sin^{-1}\left(\frac{n_2}{n_1}\right)$$

Step 2 : Solve the problem

$$\begin{aligned} \theta_c &= \sin^{-1}\left(\frac{n_2}{n_1}\right) \\ &= \sin^{-1}\left(\frac{1}{1,33}\right) \\ &= 48,8^\circ \end{aligned}$$

Step 3 : Write the final answer

The critical angle for light travelling from water to air is $48,8^\circ$.



Worked Example 38: Critical Angle 2

Question: Complete the following ray diagrams to show the path of light in each situation.

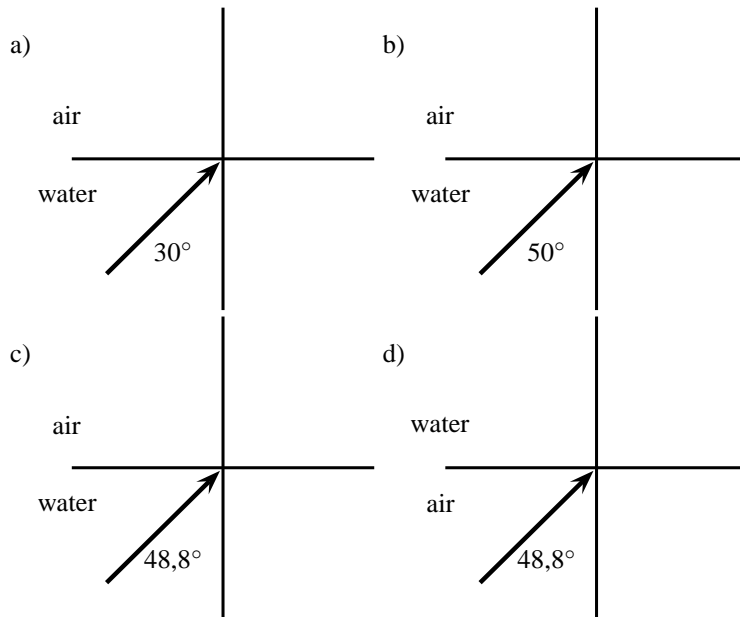
**Answer****Step 1 : Identify what is given and what is asked**

The critical angle for water is $48,8^\circ$.

We are asked to complete the diagrams.

For incident angles smaller than $48,8^\circ$ refraction will occur.

For incident angles greater than $48,8^\circ$ total internal reflection will occur.

For incident angles equal to $48,8^\circ$ refraction will occur at 90° .

The light must travel from a high optical density to a lower one.

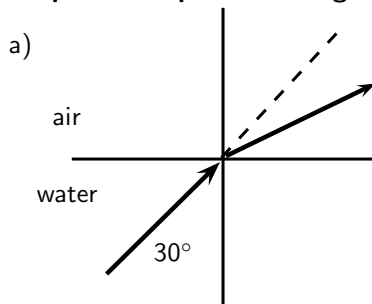
Step 2 : Complete the diagrams

Refraction occurs (ray is bent away from the normal)

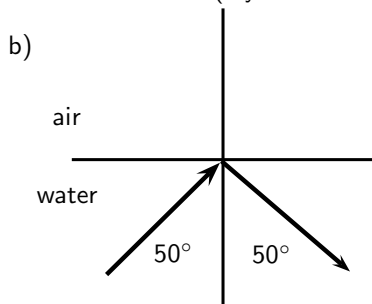

Total internal reflection occurs

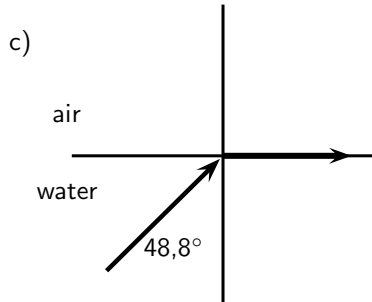

$$\theta_c = 48,8^\circ$$

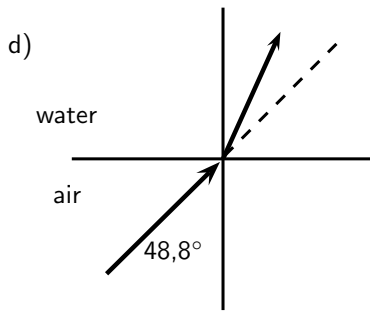

Refraction towards the normal (air is less dense than water)

7.6.2 Fibre Optics

Total internal reflection is a powerful tool since it can be used to confine light. One of the most common applications of total internal reflection is in *fibre optics*. An optical fibre is a thin, transparent fibre, usually made of glass or plastic, for transmitting light. Optical fibres are usually thinner than a human hair! The construction of a single optical fibre is shown in Figure 7.23.

The basic functional structure of an optical fibre consists of an outer protective *cladding* and an *inner core* through which light pulses travel. The overall diameter of the fibre is about $125\ \mu\text{m}$ ($125 \times 10^{-6}\ \text{m}$) and that of the core is just about $10\ \mu\text{m}$ ($10 \times 10^{-6}\ \text{m}$). The mode of operation of the optical fibres, as mentioned above, depends on the phenomenon of total internal reflection. The difference in refractive index of the cladding and the core allows total internal reflection in the same way as happens at an air-water surface. If light is incident on a cable end with an angle of incidence greater than the critical angle then the light will remain trapped inside the glass strand. In this way, light travels very quickly down the length of the cable.

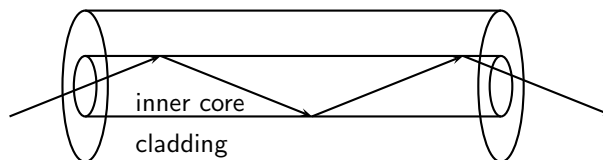

Figure 7.23: Structure of a single optical fibre.

Fibre Optics in Telecommunications

Optical fibres are most common in telecommunications, because information can be transported over long distances, with minimal loss of data. The minimised loss of data gives optical fibres an advantage over conventional cables.

Data is transmitted from one end of the fibre to another in the form of laser pulses. A single strand is capable of handling over 3000 simultaneous transmissions which is a huge improvement over the conventional co-axial cables. Multiple signal transmission is achieved by sending individual light pulses at slightly different angles. For example if one of the pulses makes a $72,23^\circ$ angle of incidence then a separate pulse can be sent at an angle of $72,26^\circ$! The transmitted data is received almost instantaneously at the other end of the cable since the information coded onto the laser travels at the speed of light! During transmission over long distances *repeater stations* are used to amplify the signal which has weakened somewhat by the time it reaches the station. The amplified signals are then relayed towards their destination and may encounter several other repeater stations on the way.

Fibre Optics in Medicine

Optic fibres are used in medicine in *endoscopes*.

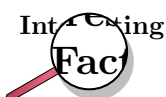

Endoscopy means *to look inside* and refers to looking inside the human body for diagnosing medical conditions.

The main part of an endoscope is the optical fibre. Light is shone down the optical fibre and a medical doctor can use the endoscope to look inside a patient. Endoscopes are used to examine the inside of a patient's stomach, by inserting the endoscope down the patient's throat.

Endoscopes allow minimally invasive surgery. This means that a person can be diagnosed and treated through a small incision. This has advantages over open surgery because endoscopy is quicker and cheaper and the patient recovers more quickly. The alternative is open surgery which is expensive, requires more time and is more traumatic for the patient.



Exercise: Total Internal Reflection and Fibre Optics

- Describe total internal reflection, referring to the conditions that must be satisfied for total internal reflection to occur.
- Define what is meant by the *critical angle* when referring to total internal reflection. Include a ray diagram to explain the concept.
- Will light travelling from diamond to silicon ever undergo total internal reflection?
- Will light travelling from sapphire to diamond undergo total internal reflection?
- What is the critical angle for light traveling from air to acetone?
- Light traveling from diamond to water strikes the interface with an angle of incidence of 86° . Calculate the critical angle to determine whether the light be totally internally reflected and so be trapped within the water.
- Which of the following interfaces will have the largest critical angle?
 - a glass to water interface
 - a diamond to water interface
 - a diamond to glass interface
- If the fibre optic strand is made from glass, determine the critical angle of the light ray so that the ray stays within the fibre optic strand.
- A glass slab is inserted in a tank of water. If the refractive index of water is 1,33 and that of glass is 1,5, find the critical angle.
- A diamond ring is placed in a container full of glycerin. If the critical angle is found to be $37,4^\circ$ and the refractive index of glycerin is given to be 1,47, find the refractive index of diamond.
- An optical fibre is made up of a core of refractive index 1,9, while the refractive index of the cladding is 1,5. Calculate the maximum angle which a light pulse can make with the wall of the core. NOTE: The question does not ask for the angle of incidence but for the angle made by the ray with the wall of the core, which will be equal to 90° - angle of incidence.

7.7 Summary

1. We can see objects when light from the objects enters our eyes.
2. Light rays are thin imaginary lines of light and are indicated in drawings by means of arrows.
3. Light travels in straight lines. Light can therefore not travel around corners. Shadows are formed because light shines in straight lines.
4. Light rays reflect off surfaces. The incident ray shines in on the surface and the reflected ray is the one that bounces off the surface. The surface normal is the perpendicular line to the surface where the light strikes the surface.
5. The angle of incidence is the angle between the incident ray and the surface, and the angle of reflection is the angle between the reflected ray and the surface.
6. The Law of Reflection states the angle of incidence is equal to the angle of reflection and that the reflected ray lies in the plane of incidence.
7. Specular reflection takes place when parallel rays fall on a surface and they leave the object as parallel rays. Diffuse reflection takes place when parallel rays are reflected in different directions.
8. Refraction is the bending of light when it travels from one medium to another. Light travels at different speeds in different media.
9. The refractive index of a medium is a measure of how easily light travels through the medium. It is a ratio of the speed of light in a vacuum to the speed of light in the medium.

$$n = \frac{c}{v}$$
10. Snell's Law gives the relationship between the refractive indices, angles of incidence and reflection of two media.

$$n_1 \sin \theta_1 = n_2 \sin \theta_2$$
11. Light travelling from one medium to another of lighter optical density will be refracted towards the normal.
 Light travelling from one medium to another of lower optical density will be refracted away from the normal.
12. Objects in a medium (e.g. under water) appear closer to the surface than they really are. This is due to the refraction of light, and the refractive index of the medium.

$$n = \frac{\text{real depth}}{\text{apparent depth}}$$
13. Mirrors are highly reflective surfaces. Flat mirrors are called plane mirrors. Curved mirrors can be convex or concave. The properties of the images formed by mirrors are summarised in Table 3.2.
14. A real image can be cast on a screen, is inverted and in front of the mirror.
 A virtual image cannot be cast on a screen, is upright and behind the mirror.
15. The magnification of a mirror is how many times the image is bigger or smaller than the object.

$$m = \frac{\text{image height } (h_i)}{\text{object height } (h_o)}$$
16. The critical angle of a medium is the angle of incidence when the angle of refraction is 90° and the refracted ray runs along the interface between the two media.
17. Total internal reflection takes place when light travels from one medium to another of lower optical density. If the angle of incidence is greater than the critical angle for the medium, the light will be reflected back into the medium. No refraction takes place.
18. Total internal reflection is used in optical fibres in telecommunication and in medicine in endoscopes. Optical fibres transmit information much more quickly and accurately than traditional methods.

7.8 Exercises

- Give one word for each of the following descriptions:
 - The image that is formed by a plane mirror.
 - The perpendicular line that is drawn at right angles to a reflecting surface at the point of incidence.
 - The bending of light as it travels from one medium to another.
 - The ray of light that falls in on an object.
 - A type of mirror that focuses all rays behind the mirror.
- State whether the following statements are TRUE or FALSE. If they are false, rewrite the statement correcting it.
 - The refractive index of a medium is an indication of how fast light will travel through the medium.
 - Total internal refraction takes place when the incident angle is larger than the critical angle.
 - The magnification of an object can be calculated if the speed of light in a vacuum and the speed of light in the medium is known.
 - The speed of light in a vacuum is about $3 \times 10^8 \text{ m.s}^{-1}$.
 - Specular reflection takes place when light is reflected off a rough surface.
- Choose words from Column B to match the concept/description in Column A. All the appropriate words should be identified. Words can be used more than once.

	<u>Column A</u>	<u>Column B</u>
(a)	Real image	Upright
(b)	Virtual image	Can be cast on a screen
(c)	Concave mirror	In front
(d)	Convex mirror	Behind
(e)	Plane mirror	Inverted
		Light travels to it
		Upside down
		Light does not reach it
		Erect
		Same size

- Complete the following ray diagrams to show the path of light.

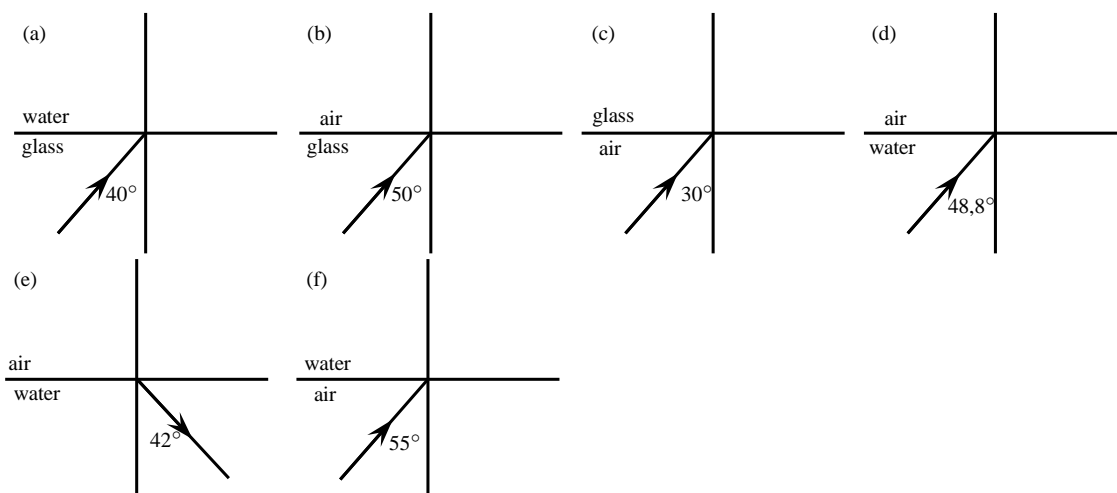

- A ray of light strikes a surface at 35° to the surface normal. Draw a ray diagram showing the incident ray, reflected ray and surface normal. Calculate the angles of incidence and reflection and fill them in on your diagram.
- Light travels from glass ($n = 1,5$) to acetone ($n = 1,36$). The angle of incidence is 25° .

- 6.1 Describe the path of light as it moves into the acetone.
 - 6.2 Calculate the angle of refraction.
 - 6.3 What happens to the speed of the light as it moves from the glass to the acetone?
 - 6.4 What happens to the wavelength of the light as it moves into the acetone?
 - 6.5 What is the name of the phenomenon that occurs at the interface between the two media?
7. A stone lies at the bottom of a swimming pool. The water is 120 cm deep. The refractive index of water is 1,33. How deep does the stone appear to be?
 8. Light strikes the interface between air and an unknown medium with an incident angle of 32° . The angle of refraction is measured to be 48° . Calculate the refractive index of the medium and identify the medium.
 9. Explain what total internal reflection is and how it is used in medicine and telecommunications. Why is this technology much better to use?
 10. A candle 10 cm high is placed 25 cm in front of a plane mirror. Draw a ray diagram to show how the image is formed. Include all labels and write down the properties of the image.
 11. A virtual image, 4 cm high, is formed 3 cm from a plane mirror. Draw a labelled ray diagram to show the position and height of the object. What is the magnification?
 12. An object, 3 cm high, is placed 4 cm from a concave mirror of focal length 2 cm. Draw a labelled ray diagram to find the position, height and properties of the image.
 13. An object, 2 cm high, is placed 3 cm from a convex mirror. The magnification is 0,5. Calculate the focal length of the mirror.

Chapter 8

Magnetism - Grade 10

8.1 Introduction

Magnetism is the force that a magnetic object exerts, through its magnetic field, on another object. The two objects do not have to physically touch each other for the force to be exerted. Object 2 feels the magnetic force from Object 1 because of Object 1's surrounding magnetic field.

Humans have known about magnetism for many thousands of years. For example, *lodestone* is a magnetised form of the iron oxide mineral *magnetite*. It has the property of attracting iron objects. It is referred to in old European and Asian historical records; from around 800 BCE in Europe and around 2 600 BCE in Asia.

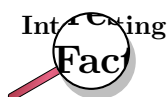

The root of the English word *magnet* is from the Greek word *magnes*, probably from Magnesia in Asia Minor, once an important source of lodestone.

8.2 Magnetic fields

A magnetic field is a region in space where a magnet or object made of ferromagnetic material will experience a non-contact force.

Electrons moving inside any object have magnetic fields associated with them. In most materials these fields point in all directions, so the net magnetic field is zero. For example, in the plastic ball below, the directions of the magnetic fields of the electrons (shown by the arrows) are pointing in different directions and cancel each other out. Therefore the plastic ball is not magnetic and has no magnetic field.

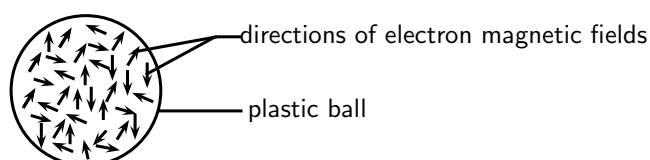

The electron magnetic fields point in all directions and so there is no net magnetic field

In some materials (e.g. iron), called **ferromagnetic** materials, there are regions called *domains*, where these magnetic fields line up. All the atoms in each domain group together so that the magnetic fields from their electrons point the same way. The picture shows a piece of an iron needle zoomed in to show the domains with the electric fields lined up inside them.

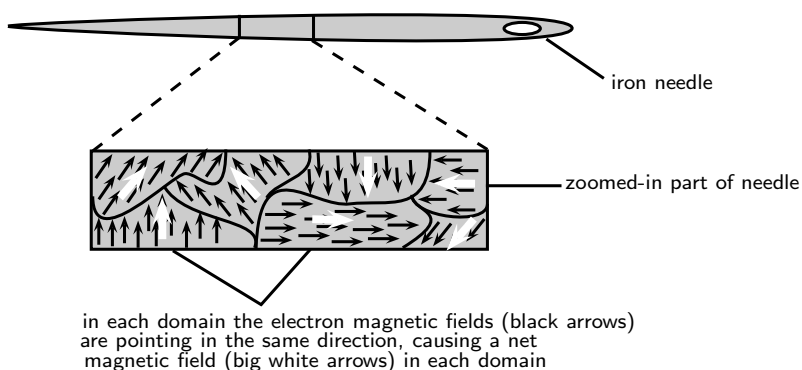

In permanent magnets, many domains are lined up, resulting in a *net magnetic field*. Objects made from ferromagnetic materials can be magnetised, for example by rubbing a magnet along the object in one direction. This causes the magnetic fields of most, or all, of the domains to line up and cause the object to have a magnetic field and be *magnetic*. Once a ferromagnetic object has been magnetised, it can stay magnetic without another magnet being nearby (i.e. without being in another magnetic field). In the picture below, the needle has been magnetised because the magnetic fields in all the domains are pointing in the same direction.

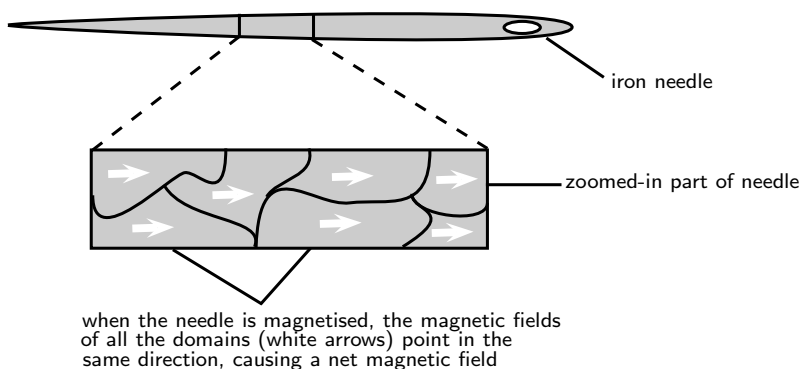

Activity :: Investigation : Ferromagnetic materials and magnetisation

1. Find 2 paper clips. Put the paper clips close together and observe what happens.
 - 1.1 **What happens to the paper clips?**
 - 1.2 **Are the paper clips magnetic?**
2. Now take a permanent bar magnet and rub it once along 1 of the paper clips. Remove the magnet and put the paper clip which was touched by the magnet close to the other paper clip and observe what happens.
 - 2.1 **Does the untouched paper clip feel a force on it? If so, is the force attractive or repulsive?**
3. Rub the same paper clip a few more times with the bar magnet, in the same direction as before. Put the paper clip close to the other one and observe what happens.
 - 3.1 **Is there any difference to what happened in step 2?**

- 3.2 **If there is a difference, what is the reason for it?**
- 3.3 **Is the paper clip which was rubbed by the magnet now magnetised?**
- 3.4 **What is the difference between the two paper clips at the level of their atoms and electrons?**
4. Now, find a *metal* knitting needle, or a plastic ruler, or other plastic object. Rub the bar magnet along the knitting needle a few times in the same direction. Now put the knitting needle close to the paper clips and observe what happens.
- 4.1 **Does the knitting needle attract the paper clips?**
- 4.2 **What does this tell you about the material of the knitting needle? Is it ferromagnetic?**
5. Repeat this experiment with objects made from other materials.
- 5.1 **Which materials appear to be ferromagnetic and which are not? Put your answers in a table.**
-

8.3 Permanent magnets

8.3.1 The poles of permanent magnets

Because the domains in a permanent magnet all line up in a particular direction, the magnet has a pair of opposite poles, called **north** (usually shortened to **N**) and **south** (usually shortened to **S**). Even if the magnet is cut into tiny pieces, each piece will still have *both* a N and a S pole. These poles *always* occur in pairs. In nature we never find a north magnetic pole or south magnetic pole on its own.

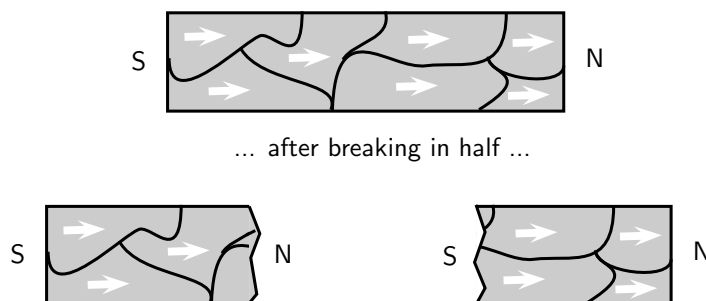

Magnetic fields are *different* to gravitational and electric fields. In nature, positive and negative electric charges can be found on their own, but you *never* find just a north magnetic pole or south magnetic pole on its own. On the very small scale, zooming in to the size of atoms, magnetic fields are caused by moving charges (i.e. the negatively charged electrons).

8.3.2 Magnetic attraction and repulsion

Like poles of magnets repel one another whilst unlike poles attract. This means that two N poles or two S poles will push away from each other while a N pole and a S pole will be drawn towards each other.



Definition: Attraction and Repulsion

Like poles of magnets *repel* each other whilst *unlike* poles *attract* each other.



Worked Example 39: Attraction and Repulsion

Question: Do you think the following magnets will repel or be attracted to each other?



Answer

Step 1 : Determine what is required

We are required to determine whether the two magnets will repel each other or be attracted to each other.

Step 2 : Determine what is given

We are given two magnets with the N pole of one approaching the N pole of the other.

Step 3 : Determine the conclusion

Since both poles are the same, the magnets will repel each other.



Worked Example 40: Attraction and repulsion

Question: Do you think the following magnets will repel or be attracted to each other?



Answer

Step 1 : Determine what is required

We are required to determine whether the two magnets will repel each other or be attracted to each other.

Step 2 : Determine what is given

We are given two magnets with the S pole of one approaching the S pole of the other.

Step 3 : Determine the conclusion

Since both poles are the different, the magnets will be attracted to each other.

8.3.3 Representing magnetic fields

Magnetic fields can be *represented* using **magnetic field lines**. Although the magnetic field of a permanent magnet is everywhere surrounding the magnet (in all 3 dimensions), we draw only some of the field lines to represent the field (usually only 2 dimensions are shown in drawings).

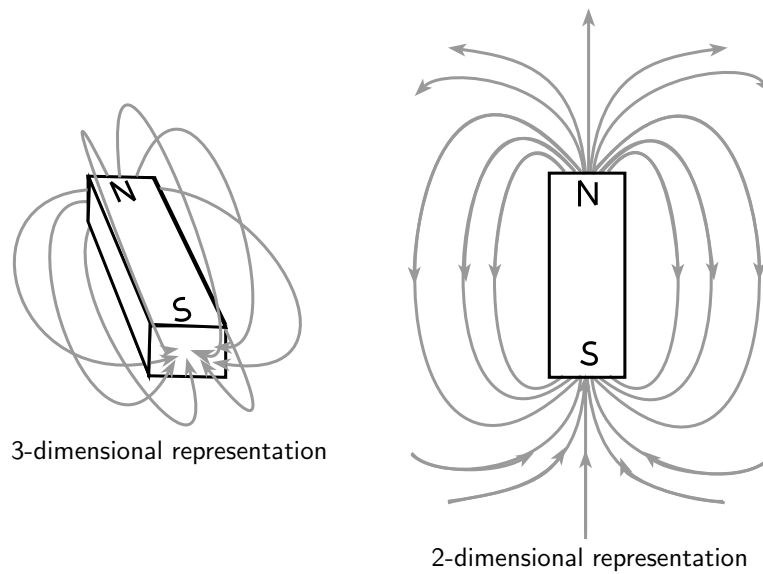

In areas where the magnetic field is strong, the field lines are closer together. Where the field is weaker, the field lines are drawn further apart. The strength of a magnetic field is referred to as the **magnetic flux**

Important:

1. Field lines *never* cross.
2. Arrows drawn on the field lines indicate the direction of the field.
3. A magnetic field points from the north to the south pole of a magnet.

Activity :: Investigation : Field around a Bar Magnet

Take a bar magnet and place it on a flat surface. Place a sheet of white paper over the bar magnet and sprinkle some iron filings onto the paper. Give the paper a shake to evenly distribute the iron filings. In your workbook, draw the bar magnet and the pattern formed by the iron filings. Draw the pattern formed when you rotate the bar magnet as shown.

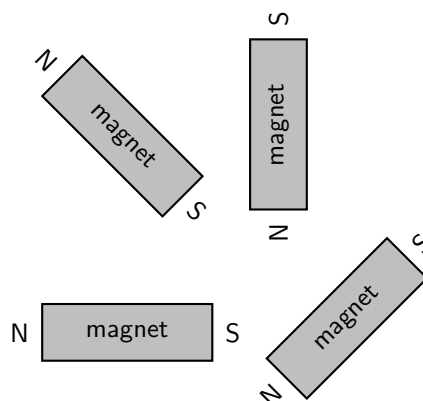

As the activity shows, one can map the magnetic field of a magnet by placing it underneath a piece of paper and sprinkling iron filings on top. The iron filings line themselves up parallel to the magnetic field.

Another tool one can use to find the direction of a magnetic field is a *compass*. The compass arrow points in the direction of the field.

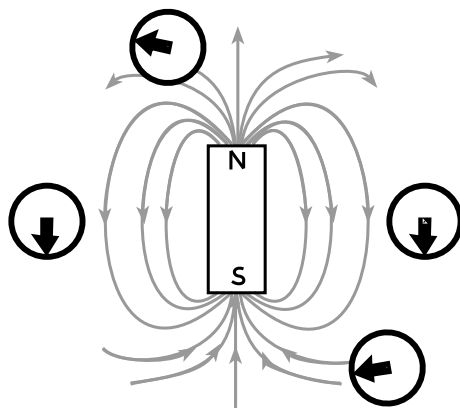

The direction of the compass arrow is the same as the direction of the magnetic field

Activity :: Investigation : Field around a Pair of Bar Magnets

Take two bar magnets and place them a short distance apart such that they are repelling each other. Place a sheet of white paper over the bar magnets and sprinkle some iron filings onto the paper. Give the paper a shake to evenly distribute the iron filings. In your workbook, draw both the bar magnets and the pattern formed by the iron filings. Repeat the procedure for two bar magnets attracting each other and draw what the pattern looks like for this situation. Make a note of the shape of the lines formed by the iron filings, as well as their size and their direction for both arrangements of the bar magnet. What does the pattern look like when you place both bar magnets side by side?

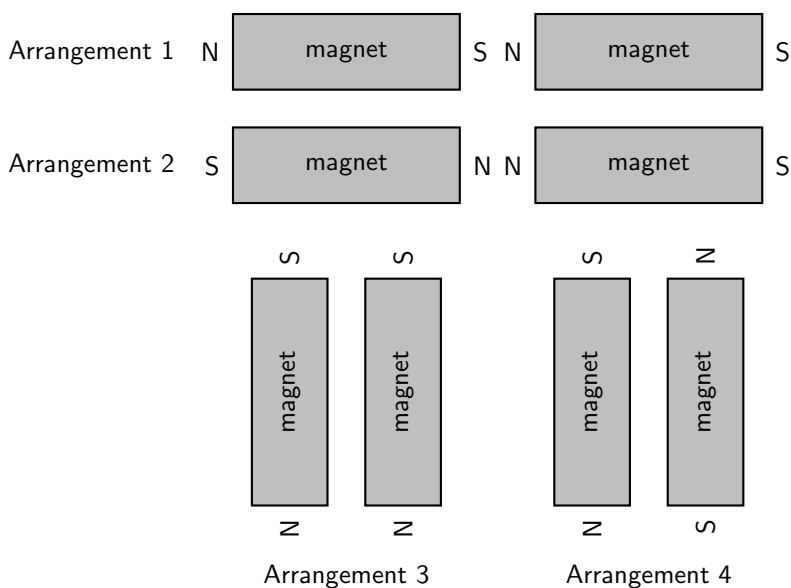

As already said, opposite poles of a magnet attract each other and bringing them together causes their magnetic field lines to *converge* (come together). Like poles of a magnet repel each other and bringing them together causes their magnetic field lines to *diverge* (bend out from each other).

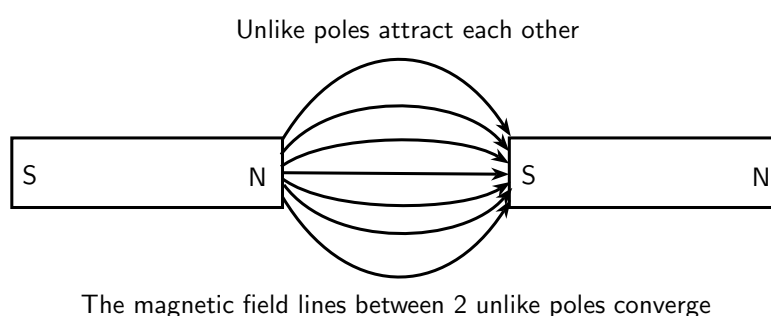
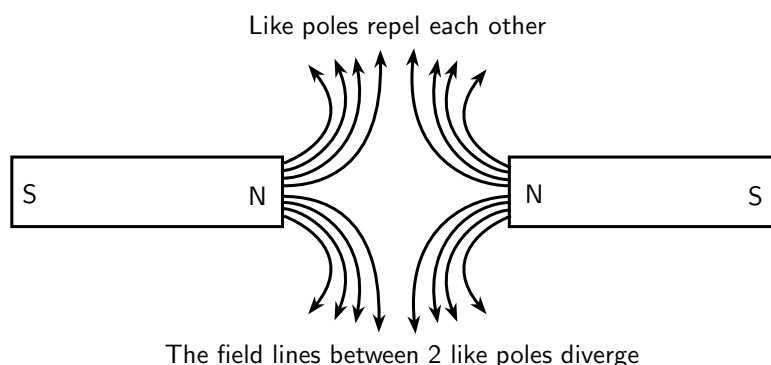

Extension: Ferromagnetism and Retentivity

Ferromagnetism is a phenomenon shown by materials like iron, nickel or cobalt. These materials can form permanent magnets. They always magnetise so as to be attracted to a magnet, no matter which magnetic pole is brought toward the unmagnetised iron/nickel/cobalt.

The ability of a ferromagnetic material to retain its magnetisation *after* an external field is removed is called its **retentivity**.

Paramagnetic materials are materials like aluminium or platinum, which become magnetised in an external magnetic field in a similar way to ferromagnetic materials. However, they lose their magnetism when the external magnetic field is removed.

Diamagnetism is shown by materials like copper or bismuth, which become magnetised in a magnetic field with a polarity *opposite* to the external magnetic field. Unlike iron, they are slightly repelled by a magnet.

8.4 The compass and the earth's magnetic field

A **compass** is an instrument which is used to find the direction of a magnetic field. It can do this because a compass consists of a small metal needle which is magnetised itself and which is free to turn in any direction. Therefore, when in the presence of a magnetic field, the needle is able to line up in the same direction as the field.

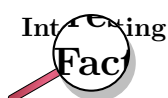

Lodestone, a magnetised form of iron-oxide, was found to orientate itself in a north-south direction if left free to rotate by suspension on a string or on a float in water. Lodestone was therefore used as an early navigational compass.

Compasses are mainly used in navigation to find direction on the earth. This works because the earth itself has a magnetic field which is similar to that of a bar magnet (see the picture below). The compass needle aligns with the magnetic field direction and points north (or south). Once you know where north is, you can figure out any other direction. A picture of a compass is shown below:

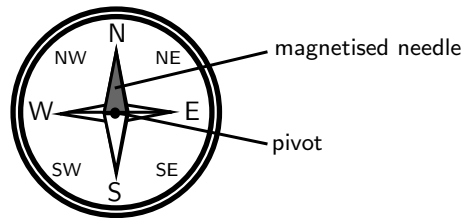

Some animals can detect magnetic fields, which helps them orientate themselves and find direction. Animals which can do this include pigeons, bees, Monarch butterflies, sea turtles and fish.

8.4.1 The earth's magnetic field

In the picture below, you can see a representation of the earth's magnetic field which is very similar to the magnetic field of a giant bar magnet like the one on the right of the picture. So the earth has two sets of north poles and south poles: **geographic poles** and **magnetic poles**.

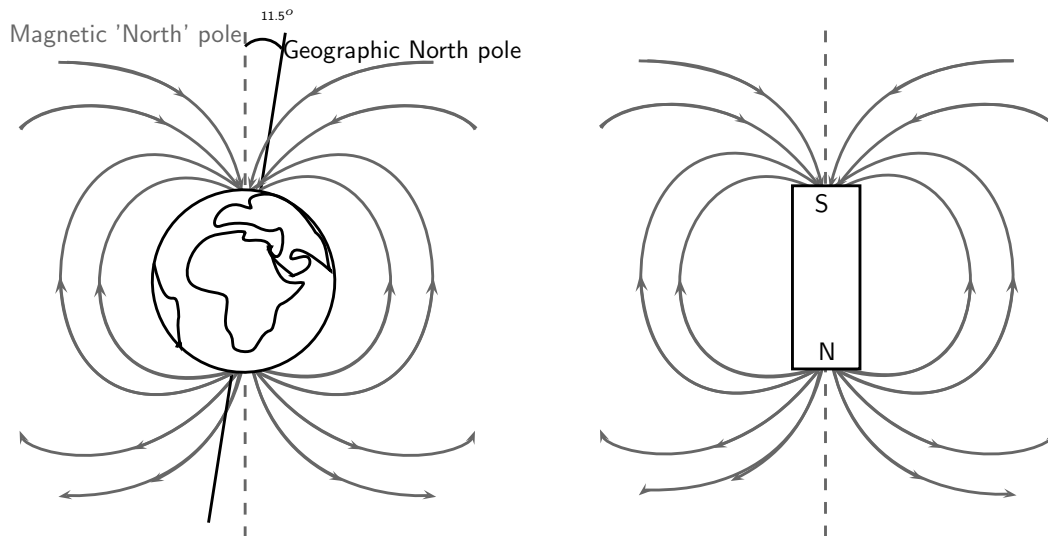

The earth's magnetic field is thought to be caused by churning liquid metals in the core which causes electric currents and a magnetic field. From the picture you can see that the direction of magnetic north and true north are not identical. The **geographic north pole**, which is the point through which the earth's rotation axis goes, is about $11,5^\circ$ away from the direction of the **magnetic north pole** (which is where a compass will point). However, the magnetic poles shift slightly all the time.

Another interesting thing to note is that if we think of the earth as a big bar magnet, and we know that magnetic field lines always point *from north to south*, then the compass tells us that what we call the *magnetic north pole* is actually the *south pole* of the bar magnet!

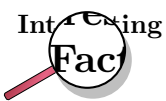

The direction of the earth's magnetic field flips direction about once every 200 000 years! You can picture this as a bar magnet whose north and south pole periodically switch sides. The reason for this is still not fully understood.

The earth's magnetic field is very important for humans and other animals on earth because it stops charged particles emitted by the sun from hitting the earth and us. Charged particles can also damage and cause interference with telecommunications (such as cell phones). Charged particles (mainly protons and electrons) are emitted by the sun in what is called the solar wind, and travel towards the earth. These particles spiral in the earth's magnetic field towards the poles. If they collide with other particles in the earth's atmosphere they sometimes cause red or green lights or a glow in the sky which is called the aurora. This happens close to the north and south pole and so we cannot see the aurora from South Africa.

8.5 Summary

1. Magnets have two poles - North and South.

2. Some substances can be easily magnetised.
3. Like poles repel each other and unlike poles attract each other.
4. The Earth also has a magnetic field.
5. A compass can be used to find the magnetic north pole and help us find our direction.

8.6 End of chapter exercises

1. Describe what is meant by the term *magnetic field*.
2. Use words and pictures to explain why permanent magnets have a magnetic field around them. Refer to *domains* in your explanation.
3. What is a magnet?
4. What happens to the poles of a magnet if it is cut into pieces?
5. What happens when like magnetic poles are brought close together?
6. What happens when unlike magnetic poles are brought close together?
7. Draw the shape of the magnetic field around a bar magnet.
8. Explain how a compass indicates the direction of a magnetic field.
9. Compare the magnetic field of the Earth to the magnetic field of a bar magnet using words and diagrams.
10. Explain the difference between the geographical north pole and the magnetic north pole of the Earth.
11. Give examples of phenomena that are affected by Earth's magnetic field.
12. Draw a diagram showing the magnetic field around the Earth.

Chapter 9

Electrostatics - Grade 10

9.1 Introduction

Electrostatics is the study of electric charge which is static (not moving).

9.2 Two kinds of charge

All objects surrounding us (including people!) contain large amounts of electric charge. There are two types of electric charge: **positive** charge and **negative** charge. If the same amounts of negative and positive charge are brought together, they neutralise each other and there is no net charge. **Neutral** objects are objects which contain positive and negative charges, but in equal numbers. However, if there is a little bit more of one type of charge than the other on the object then the object is said to be **electrically charged**. The picture below shows what the distribution of charges might look like for a neutral, positively charged and negatively charged object.

There are:

6 positive charges and
6 negative charges

$$6 + (-6) = 0$$

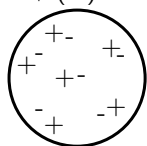

There is zero net charge:
The object is neutral

8 positive charges and
6 negative charges

$$8 + (-6) = 2$$

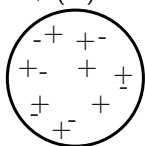

The net charge is +2
The object is positively charged

6 positive charges and
9 negative charges

$$6 + (-9) = -3$$

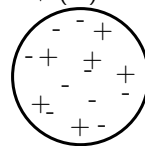

The net charge is -3

The object is negatively charged

9.3 Unit of charge

Charge is measured in units called **coulombs (C)**. A coulomb of charge is a very large charge. In electrostatics we therefore often work with charge in microcoulombs ($1 \mu\text{C} = 1 \times 10^{-6} \text{ C}$) and nanocoulombs ($1 \text{ nC} = 1 \times 10^{-9} \text{ C}$).

9.4 Conservation of charge

Objects can become charged by contact or by rubbing them. This means that they can gain extra negative or positive charge. Charging happens when you, for example, rub your feet against the carpet. When you then touch something metallic or another person, you will feel a shock as

the excess charge that you have collected is *discharged*.



Important: Charge, just like energy, cannot be created or destroyed. We say that charge is **conserved**.

When you rub your feet against the carpet, negative charge is transferred to you from the carpet. The carpet will then become positively charged by the *same amount*.

Another example is to take two *neutral* objects such as a plastic ruler and a cotton cloth (handkerchief). To begin, the two objects are neutral (i.e. have the same amounts of positive and negative charge.)

BEFORE rubbing:

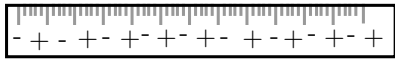

The ruler has 9 positive charges and 9 negative charges

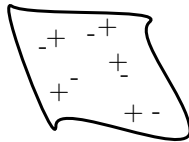

The neutral cotton cloth has 5 positive charges and 5 negative charges

The total number of charges is:

$(9+5)=14$ positive charges

$(9+5)=14$ negative charges

Now, if the cotton cloth is used to rub the ruler, negative charge is transferred *from* the cloth *to* the ruler. The ruler is now *negatively* charged and the cloth is *positively* charged. If you count up all the positive and negative charges at the beginning and the end, there are still the same amount. i.e. total charge has been *conserved*!

AFTER rubbing:



The ruler has 9 positive charges and 12 negative charges
It is now negatively charged.

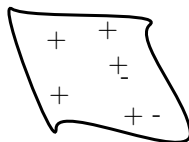

The cotton cloth has 5 positive charges and 2 negative charges.
It is now positively charged.

The total number of charges is:

$(9+5)=14$ positive charges

$(12+2)=14$ negative charges

Charges have been transferred from the cloth to the ruler BUT total charge has been conserved!

9.5 Force between Charges

The force exerted by non-moving (static) charges on each other is called the **electrostatic force**. The electrostatic force between:

- **like** charges is **repulsive**
- **opposite** (unlike) charges is **attractive**.

In other words, like charges repel each other while opposite charges attract each other. This is different to the gravitational force which is only attractive.

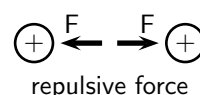
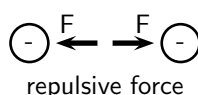
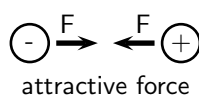

The *closer* together the charges are, the *stronger* the electrostatic force between them.

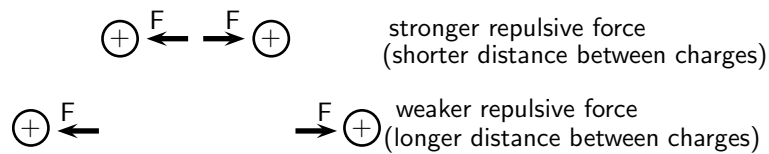

Activity :: Experiment : Electrostatic Force

You can easily test that like charges repel and unlike charges attract each other by doing a very simple experiment.

Take a glass rod and rub it with a piece of silk, then hang it from its middle with a piece of string so that it is free to move. If you then bring another glass rod which you have also charged in the same way next to it, you will see the rod on the string turn *away* from the rod in your hand i.e. it is **repelled**. If, however, you take a plastic rod, rub it with a piece of fur and then bring it close to the rod on the string, you will see the rod on the string turn *towards* the rod in your hand i.e. it is **attracted**.

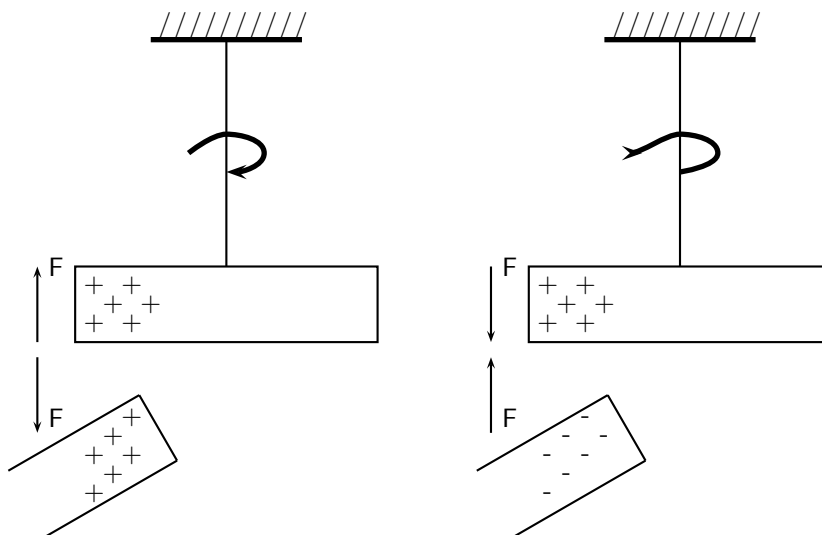

This happens because when you rub the glass with silk, tiny amounts of negative charge are transferred from the glass onto the silk, which causes the glass to have less negative charge than positive charge, making it **positively charged**. When you rub the plastic rod with the fur, you transfer tiny amounts of negative charge onto the rod and so it has more negative charge than positive charge on it, making it **negatively charged**.



Worked Example 41: Application of electrostatic forces

Question: Two charged metal spheres hang from strings and are free to move as shown in the picture below. The right hand sphere is positively charged. The charge on the left hand sphere is unknown.

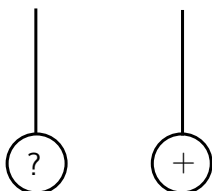

The left sphere is now brought close to the right sphere.

1. If the left hand sphere swings towards the right hand sphere, what can you say about the charge on the left sphere and why?
2. If the left hand sphere swings away from the right hand sphere, what can you say about the charge on the left sphere and why?

Answer

Step 1 : Identify what is known and what question you need to answer:

In the first case, we have a sphere with positive charge which is *attracting* the left charged sphere. We need to find the charge on the left sphere.

Step 2 : What concept is being used?

We are dealing with electrostatic forces between charged objects. Therefore, we know that *like charges repel* each other and *opposite charges attract* each other.

Step 3 : Use the concept to find the solution

1. In the first case, the positively charged sphere is attracting the left sphere. Since an electrostatic force between unlike charges is attractive, the left sphere must be *negatively* charged.
2. In the second case, the positively charged sphere repels the left sphere. Like charges repel each other. Therefore, the left sphere must now also be *positively* charged.



Extension: Electrostatic Force

The electrostatic force determines the arrangement of charge on the surface of conductors. When we place a charge on a spherical conductor the repulsive forces between the individual like charges cause them to spread uniformly over the surface of the sphere. However, for conductors with non-regular shapes, there is a concentration of charge near the point or points of the object.

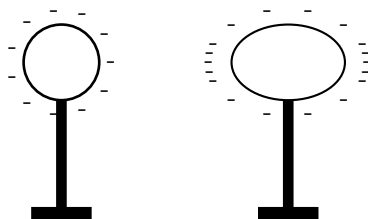

This collection of charge can actually allow charge to leak off the conductor if the point is sharp enough. It is for this reason that buildings often have a lightning rod on the roof to remove any charge the building has collected. This minimises the possibility of the building being struck by lightning. This “spreading out” of charge would not occur if we were to place the charge on an insulator since charge cannot move in insulators.

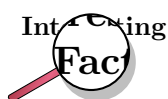

The word 'electron' comes from the Greek word for amber. The ancient Greeks observed that if you rubbed a piece of amber, you could use it to pick up bits of straw.

9.6 Conductors and insulators

All atoms are electrically neutral i.e. they have the same amounts of negative and positive charge inside them. By convention, the electrons carry negative charge and the protons carry positive charge. The basic unit of charge, called the elementary charge, e , is the amount of charge carried by one electron.

All the matter and materials on earth are made up of atoms. Some materials allow electrons to move relatively freely through them (e.g. most metals, the human body). These materials are called **conductors**.

Other materials do not allow the charge carriers, the electrons, to move through them (e.g. plastic, glass). The electrons are bound to the atoms in the material. These materials are called **non-conductors** or **insulators**.

If an excess of charge is placed on an insulator, it will stay where it is put and there will be a concentration of charge in that area of the object. However, if an excess of charge is placed on a conductor, the like charges will repel each other and spread out over the surface of the object. When two conductors are made to touch, the total charge on them is shared between the two. If the two conductors are identical, then each conductor will be left with half of the total charge.



Extension: Charge and electrons

The basic unit of charge, namely the elementary charge is carried by the electron (equal to 1.602×10^{-19} C!). In a conducting material (e.g. copper), when the atoms bond to form the material, some of the outermost, loosely bound electrons become detached from the individual atoms and so become free to move around. The charge carried by these electrons can move around in the material. In insulators, there are very few, if any, free electrons and so the charge cannot move around in the material.



Worked Example 42: Conducting spheres and movement of charge

Question: I have 2 charged metal conducting spheres. Sphere A has a charge of -5 nC and sphere B has a charge of -3 nC. I then bring the spheres together so that they touch each other. Afterwards I move the two spheres apart so that they are no longer touching.

1. What happens to the charge on the two spheres?
2. What is the final charge on each sphere?

Answer

Step 1 : Identify what is known and what question/s we need to answer:

We have two identical negatively charged conducting spheres which are brought together to touch each other and then taken apart again. We need to explain what

happens to the charge on each sphere and what the final charge on each sphere is after they are moved apart.

Step 2 : What concept is being used?

We know that the charge carriers in conductors are free to move around and that charge on a conductor spreads itself out on the surface of the conductor.

Step 3 : Use the concept to find the answer

1. When the two conducting spheres are brought together to touch, it is as though they become one single big conductor and the total charge of the two spheres spreads out across the whole surface of the touching spheres. When the spheres are moved apart again, each one is left with half of the total original charge.
2. Before the spheres touch, the total charge is: $-5 \text{ nC} + (-3) \text{ nC} = -8 \text{ nC}$. When they touch they share out the -8 nC across their whole surface. When they are removed from each other, each is left with half of the original charge:

$$-8 \text{ nC} / 2 = -4 \text{ nC}$$

on each sphere.

9.6.1 The electroscope

The electroscope is a very sensitive instrument which can be used to detect electric charge. A diagram of a gold leaf electroscope is shown in the figure below. The electroscope consists of a glass container with a metal rod inside which has 2 thin pieces of gold foil attached. The other end of the metal rod has a metal plate attached to it outside the glass container.

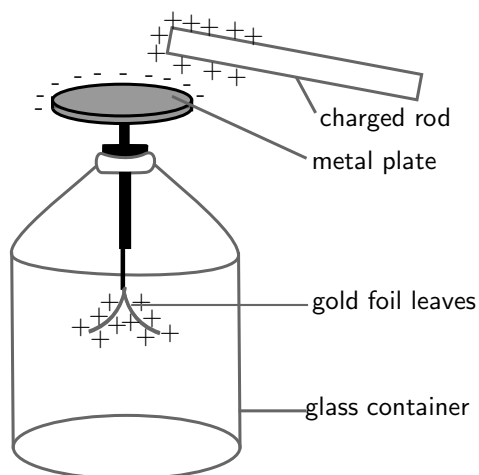

The electroscope detects charge in the following way: A charged object, like the positively charged rod in the picture, is brought close to (but not touching) the neutral metal plate of the electroscope. This causes negative charge in the gold foil, metal rod, and metal plate, to be attracted to the positive rod. Because the metal (gold is a metal too!) is a conductor, the charge can move freely from the foil up the metal rod and onto the metal plate. There is now more negative charge on the plate and more positive charge on the gold foil leaves. This is called *inducing* a charge on the metal plate. It is important to remember that the electroscope is still neutral (the total positive and negative charges are the same), the charges have just been induced to *move* to different parts of the instrument! The induced positive charge on the gold leaves forces them apart since like charges repel! This is how we can tell that the rod is charged. If the rod is now moved away from the metal plate, the charge in the electroscope will spread itself out evenly again and the leaves will fall down again because there will no longer be an induced charge on them.

Grounding

If you were to bring the charged rod close to the uncharged electroscope, and then you touched the metal plate with your finger at the same time, this would cause charge to flow up from the ground (the earth), through your body onto the metal plate. This is called **grounding**. The charge flowing onto the plate is opposite to the charge on the rod, since it is attracted to the rod. Therefore, for our picture, the charge flowing onto the plate would be negative. Now charge has been added to the electroscope. It is no longer neutral, but has an excess of negative charge. Now if we move the rod away, the leaves will remain apart because they have an excess of negative charge and they repel each other.

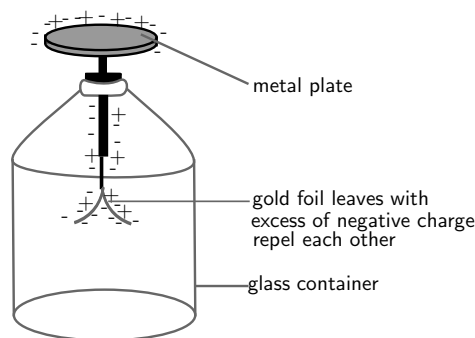

9.7 Attraction between charged and uncharged objects

9.7.1 Polarisation of Insulators

Unlike conductors, the electrons in insulators (non-conductors) are bound to the atoms of the insulator and cannot move around freely in the material. However, a charged object can still exert a force on a neutral insulator through the concept of **polarisation**.

If a positively charged rod is brought close to a neutral insulator such as polystyrene, it can attract the bound electrons to move round to the side of the atoms which is closest to the rod and cause the positive nuclei to move slightly to the opposite side of the atoms. This process is called *polarisation*. Although it is a very small (microscopic) effect, if there are many atoms and the polarised object is light (e.g. a small polystyrene ball), it can add up to enough force to be attracted onto the charged rod. Remember, that the polystyrene is *only* polarised, *not* charged. The polystyrene ball is still neutral since no charge was added or removed from it. The picture shows a not-to-scale view of the polarised atoms in the polystyrene ball:

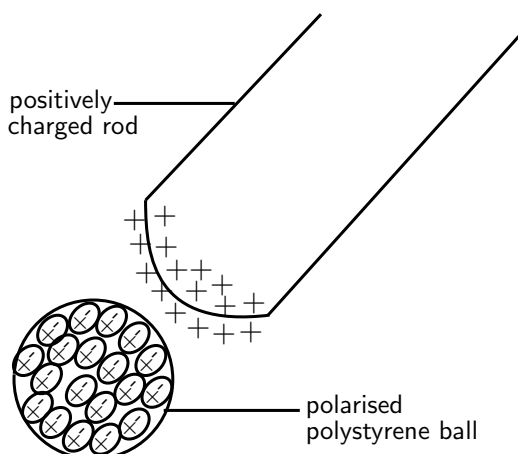

Some materials are made up of molecules which are already polarised. These are molecules which have a more positive and a more negative side but are still neutral overall. Just as a polarised polystyrene ball can be attracted to a charged rod, these materials are also affected if brought close to a charged object.

Water is an example of a substance which is made of polarised molecules. If a positively charged rod is brought close to a stream of water, the molecules can rotate so that the negative sides all line up towards the rod. The stream of water will then be attracted to the rod since opposite charges attract.

9.8 Summary

1. Objects can be **positively** charged, **negatively** charged or **neutral**.
2. Objects that are neutral have equal numbers of positive and negative charge.
3. Unlike charges are attracted to each other and like charges are repelled from each other.
4. Charge is neither created nor destroyed, it can only be transferred.
5. Charge is measured in coulombs (C).
6. Conductors allow charge to move through them easily.
7. Insulators do not allow charge to move through them easily.

9.9 End of chapter exercise

1. What are the two types of charge called?
2. Provide evidence for the existence of two types of charge.
3. The electrostatic force between like charges is ????? while the electrostatic force between opposite charges is ?????.
4. I have two positively charged metal balls placed 2 m apart.
 - 4.1 Is the electrostatic force between the balls attractive or repulsive?
 - 4.2 If I now move the balls so that they are 1 m apart, what happens to the strength of the electrostatic force between them?
5. I have 2 charged spheres each hanging from string as shown in the picture below.

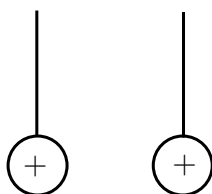

Choose the correct answer from the options below: The spheres will

- 5.1 swing towards each other due to the attractive electrostatic force between them.
 - 5.2 swing away from each other due to the attractive electrostatic force between them.
 - 5.3 swing towards each other due to the repulsive electrostatic force between them.
 - 5.4 swing away from each other due to the repulsive electrostatic force between them.
6. Describe how objects (insulators) can be charged by contact or rubbing.
 7. You are given a perspex ruler and a piece of cloth.
 - 7.1 How would you charge the perspex ruler?
 - 7.2 Explain how the ruler becomes charged in terms of charge.
 - 7.3 How does the charged ruler attract small pieces of paper?

8. [IEB 2005/11 HG] An uncharged hollow metal sphere is placed on an insulating stand. A positively charged rod is brought up to touch the hollow metal sphere at P as shown in the diagram below. It is then moved away from the sphere.

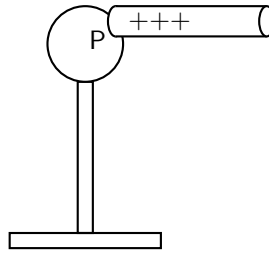

- Where is the excess charge distributed on the sphere after the rod has been removed?
- 8.1 It is still located at point P where the rod touched the sphere.
 - 8.2 It is evenly distributed over the outer surface of the hollow sphere.
 - 8.3 It is evenly distributed over the outer and inner surfaces of the hollow sphere.
 - 8.4 No charge remains on the hollow sphere.
9. What is the process called where molecules in an uncharged object are caused to align in a particular direction due to an external charge?
10. Explain how an uncharged object can be attracted to a charged object. You should use diagrams to illustrate your answer.
11. Explain how a stream of water can be attracted to a charged rod.

Chapter 10

Electric Circuits - Grade 10

10.1 Electric Circuits

In South Africa, people depend on electricity to provide power for most appliances in the home, at work and out in the world in general. For example, fluorescent lights, electric heating and cooking (on electric stoves), all depend on electricity to work. To realise just how big an impact electricity has on our daily lives, just think about what happens when there is a power failure or load shedding.

Activity :: Discussion : Uses of electricity

With a partner, take the following topics and, for each topic, write down at least 5 items/appliances/machines which need electricity to work. Try not to use the same item more than once.

- At home
- At school
- At the hospital
- In the city

Once you have finished making your lists, compare with the lists of other people in your class. (Save your lists somewhere safe for later because there will be another activity for which you'll need them.)

When you start comparing, you should notice that there are many different items which we use in our daily lives which rely on electricity to work!



Important: Safety Warning: We believe in experimenting and learning about physics at every opportunity, BUT playing with electricity can be **EXTREMELY DANGEROUS!** Do not try to build home made circuits alone. Make sure you have someone with you who knows if what you are doing is safe. Normal electrical outlets are dangerous. Treat electricity with respect in your everyday life.

10.1.1 Closed circuits

In the following activity we will investigate what is needed to cause charge to flow in an electric circuit.

Activity :: Experiment : Closed circuits**Aim:**

To determine what is required to make electrical charges flow. In this experiment, we will use a lightbulb to check whether electrical charge is flowing in the circuit or not. If charge is flowing, the lightbulb should glow. On the other hand, if no charge is flowing, the lightbulb will not glow.

Apparatus:

You will need a small lightbulb which is attached to a metal conductor (e.g. a bulb from a school electrical kit), some connecting leads and a battery.

Method:

Take the apparatus items and try to connect them in a way that you cause the light bulb to glow (i.e. charge flows in the circuit).

Questions:

1. Once you have arranged your circuit elements to make the lightbulb glow, draw your circuit.
2. What can you say about how the battery is connected? (i.e. does it have one or two connecting leads attached? Where are they attached?)
3. What can you say about how the light bulb is connected in your circuit? (i.e. does it connect to one or two connecting leads, and where are they attached?)
4. Are there any items in your circuit which are not attached to something? In other words, are there any gaps in your circuit?

Write down your conclusion about what is needed to make an electric circuit work and charge to flow.

In the experiment above, you will have seen that the light bulb only glows when there is a *closed* circuit i.e. there are no gaps in the circuit and all the circuit elements are connected in a *closed loop*. Therefore, in order for charges to flow, a closed circuit and an energy source (in this case the battery) are needed. (Note: you do not have to have a lightbulb in the circuit! We used this as a check that charge was flowing.)

**Definition: Electric circuit**

An electric circuit is a closed path (with no breaks or gaps) along which electrical charges (electrons) flow powered by an energy source.





10.1.2 Representing electric circuits**Components of electrical circuits**

Some common elements (components) which can be found in electrical circuits include light bulbs, batteries, connecting leads, switches, resistors, voltmeters and ammeters. You will learn more about these items in later sections, but it is important to know what their symbols are and how to represent them in circuit diagrams. Below is a table with the items and their symbols:

Circuit diagrams**Definition: Representing circuits**

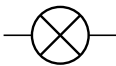
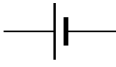
A **physical circuit** is the electric circuit you create with real components.

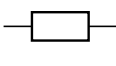
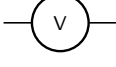
A **circuit diagram** is a drawing which uses symbols to represent the different components in the physical circuit.

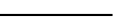
Component	Symbol	Usage
light bulb		glows when charge moves through it
battery		provides energy for charge to move
switch		allows a circuit to be open or closed
resistor	 	resists the flow of charge
voltmeter		measures potential difference
ammeter		measures current in a circuit
connecting lead		connects circuit elements together

We use circuit diagrams to represent circuits because they are much simpler and more general than drawing the physical circuit because they only show the workings of the electrical components. You can see this in the two pictures below. The first picture shows the *physical circuit* for an electric torch. You can see the light bulb, the batteries, the switch and the outside plastic casing of the torch. The picture is actually a *cross-section* of the torch so that we can see inside it.

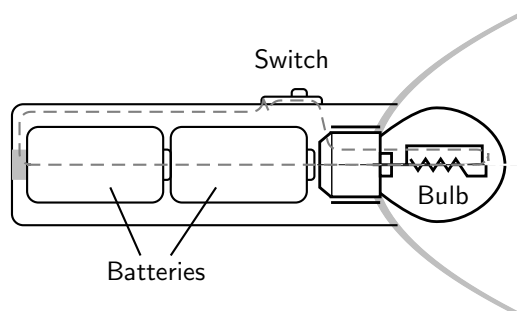

Figure 10.1: Physical components of an electric torch. The dotted line shows the path of the electrical circuit.

Below is the *circuit diagram* for the electric torch. Now the light bulb is represented by its symbol, as are the batteries, the switch and the connecting wires. It is not necessary to show the plastic casing of the torch since it has nothing to do with the electric workings of the torch. You can see that the circuit diagram is much simpler than the physical circuit drawing!

Series and parallel circuits

There are two ways to connect electrical components in a circuit: **in series** or **in parallel**.

Definition: Series circuit

In a series circuit, the charge has a **single** path from the battery, returning to the battery.



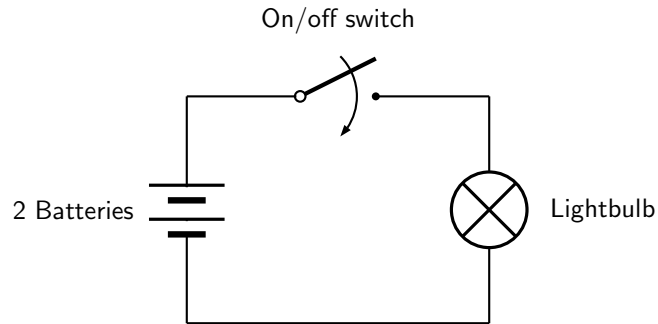
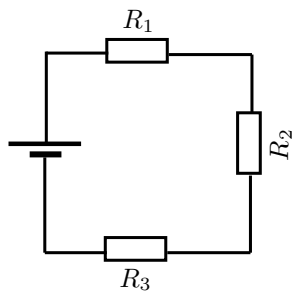

Figure 10.2: Circuit diagram of an electric torch.

**Definition: Parallel circuit**

In a parallel circuit, the charge has **multiple** paths from the battery, returning to the battery.

The picture below shows a circuit with three resistors connected *in series* on the left and a circuit with three resistors connected *in parallel* on the right:



3 resistors in a series circuit

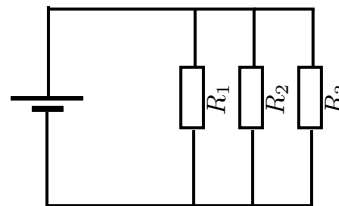

3 resistors in a parallel circuit

**Worked Example 43: Drawing circuits I**

Question: Draw the circuit diagram for a circuit which has the following components:

1. 1 battery
2. 1 lightbulb connected in series
3. 2 resistors connected in parallel

Answer

Step 1 : Identify the components and their symbols and draw according to the instructions:

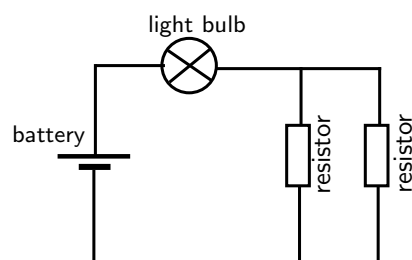



Worked Example 44: Drawing circuits II

Question: Draw the circuit diagram for a circuit which has the following components:

1. 3 batteries in series
2. 1 lightbulb connected in parallel with 1 resistor
3. a switch in series

Answer

Step 1 : Identify the symbol for each component and draw according to the instructions:

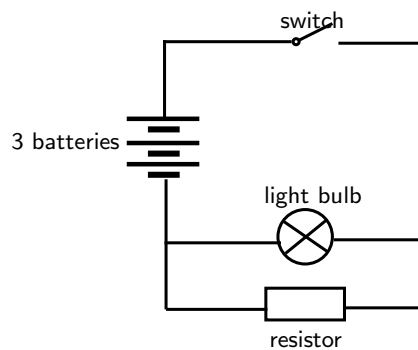

Exercise: Circuits

1. Using physical components, set up the physical circuit which is described by the circuit diagram below:

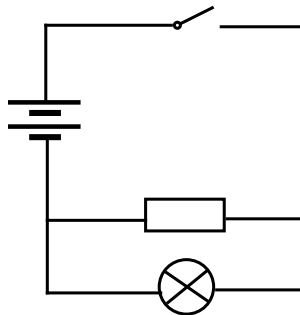

- 1.1 Now draw a picture of the physical circuit you have built.
2. Using physical components, set up a closed circuit which has one battery and a light bulb in series with a resistor.
 - 2.1 Draw the physical circuit.
 - 2.2 Draw the resulting circuit diagram.
 - 2.3 How do you know that you have built a closed circuit? (What happens to the light bulb?)
 - 2.4 If you add one more resistor to your circuit (also in series), what do you notice? (What happens to the light from the light bulb?)
 - 2.5 Draw the new circuit diagram which includes the second resistor.
3. Draw the circuit diagram for the following circuit: 2 batteries, a switch in series and 1 lightbulb which is in parallel with two resistors.
 - 3.1 Now use physical components to set up the circuit.

- 3.2 What happens when you close the switch? What does this mean about the circuit?
- 3.3 Draw the physical circuit.
-
-

Activity :: Discussion : Alternative Energy

At the moment, electric power is produced by burning fossil fuels such as coal and oil. In South Africa, our main source of electric power is coal burning power stations. (We also have one nuclear power plant called Koeberg in the Western Cape). However, burning fossil fuels releases large amounts of pollution into the earth's atmosphere and can contribute to global warming. Also, the earth's fossil fuel reserves (especially oil) are starting to run low. For these reasons, people all across the world are working to find *alternative*/other sources of energy and on ways to *conserve*/save energy. Other sources of energy include wind power, solar power (from the sun), hydro-electric power (from water) among others.

With a partner, take out the lists you made earlier of the item/appliances/machines which used electricity in the following environments. For each item, try to think of an *alternative* AND a way to *conserve* or save power.

For example, if you had a fluorescent light as an item used in the home, then:

- Alternative: use candles at supper time to reduce electricity consumption
- Conservation: turn off lights when not in a room, or during the day.

Topics:

- At home
- At school
- At the hospital
- In the city

Once you have finished making your lists, compare with the lists of other people in your class.

10.2 Potential Difference

10.2.1 Potential Difference

When a circuit is connected and is a complete circuit charge can move through the circuit. Charge will not move unless there is a reason, a force. Think of it as though charge is at rest and something has to push it along. This means that work needs to be done to make charge move. A force acts on the charges, doing work, to make them move. The force is provided by the battery in the circuit.

We call the moving charge "current" and we will talk about this later.

The position of the charge in the circuit tells you how much potential energy it has because of the force being exerted on it. This is like the force from gravity, the higher an object is above the ground (position) the more potential energy it has.

The amount of work to move a charge from one point to another point is how much the potential energy has changed. This is the difference in potential energy, called potential difference. Notice that it is a difference between the value of potential energy at two points so we say that potential difference is measured between or across two points. We do not say potential difference through something.



Definition: Potential Difference

Electrical potential difference as the difference in electrical potential energy per unit charge between two points. The units of potential difference are the volt (V).

The units are volt (V), which is the same as joule per coulomb, the amount of work done per unit charge. Electrical potential difference is also called voltage.

10.2.2 Potential Difference and Parallel Resistors

When resistors are connected in parallel the start and end points for all the resistors are the same. These points have the same potential energy and so the potential difference between them is the same no matter what is put in between them. You can have one, two or many resistors between the two points, the potential difference will not change. You can ignore whatever components are between two points in a circuit when calculating the difference between the two points.

Look at the following circuit diagrams. The battery is the same in all cases, all that changes is more resistors are added between the points marked by the black dots. If we were to measure the potential difference between the two dots in these circuits we would get the same answer for all three cases.

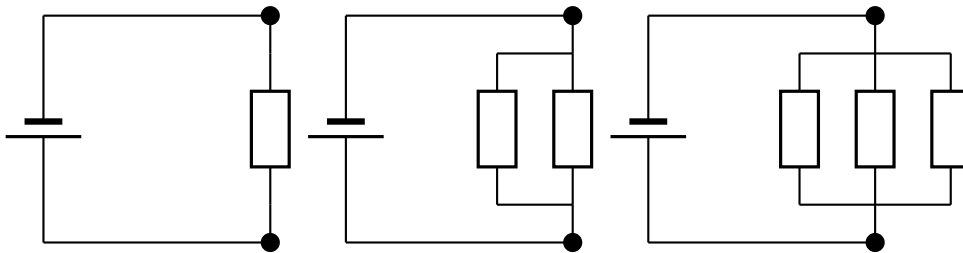

Lets look at two resistors in parallel more closely. When you construct a circuit you use wires and you might think that measuring the voltage in different places on the wires will make a difference. This is not true. The potential difference or voltage measurement will only be different if you measure a different set of components. All points on the wires that have no circuit components between them will give you the same measurements.

All three of the measurements shown in the picture below will give you the same voltages. The different measurement points on the left have no components between them so there is no change in potential energy. Exactly the same applies to the different points on the right. When you measure the potential difference between the points on the left and right you will get the same answer.

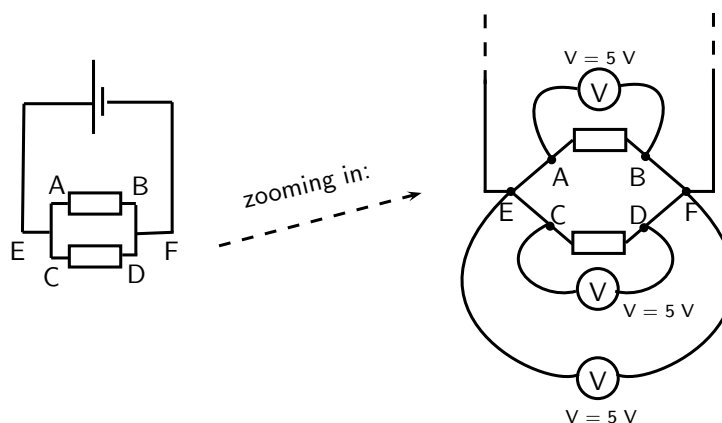

10.2.3 Potential Difference and Series Resistors

When resistors are in series, one after the other, there is a potential difference across each resistor. The total potential difference across a set of resistors in series is the sum of the potential differences across each of the resistors in the set. This is the same as falling a large distance under gravity or falling that same distance (difference) in many smaller steps. The total distance (difference) is the same.

Look at the circuits below. If we measured the potential difference between the black dots in all of these circuits it would be the same just like we saw above. So we now know the total potential difference is the same across one, two or three resistors. We also know that some work is required to make charge flow through each one, each is a step down in potential energy. These steps add up to the total drop which we know is the difference between the two dots.

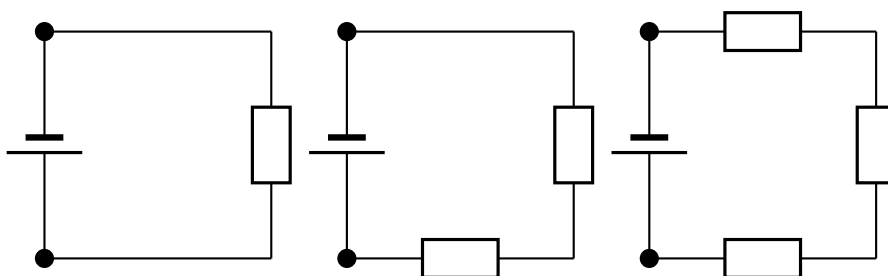

Let us look at this in a bit more detail. In the picture below you can see what the different measurements for 3 identical resistors in series could look like. The total voltage across all three resistors is the sum of the voltages across the individual resistors.

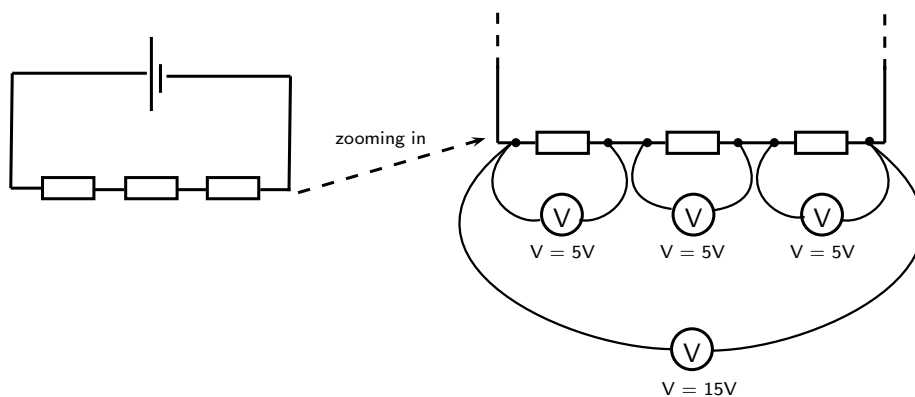

10.2.4 Ohm's Law

The voltage is the change in potential energy or work done when charge moves between two points in the circuit. The greater the resistance to charge moving the more work that needs to be done. The work done or voltage thus depends on the resistance. The potential difference is proportional to the resistance.



Definition: Ohm's Law

Voltage across a circuit component is proportional to the resistance of the component.

Use the fact that voltage is proportional to resistance to calculate what proportion of the total voltage of a circuit will be found across each circuit element.

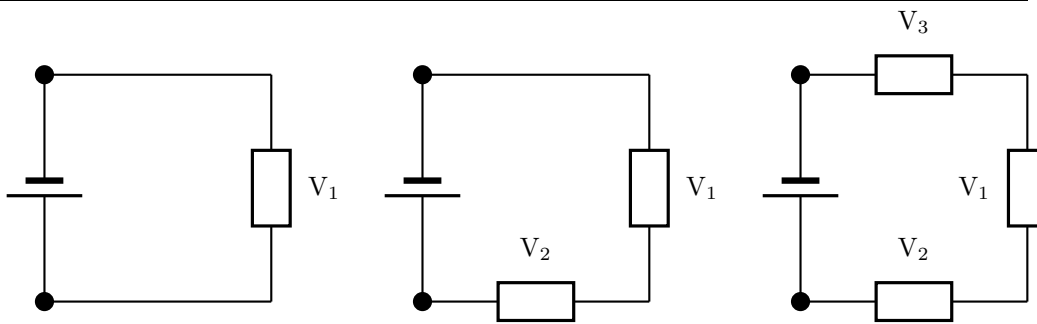

We know that the total voltage is equal to V_1 in the first circuit, to $V_1 + V_2$ in the second circuit and $V_1 + V_2 + V_3$ in the third circuit.

We know that the potential energy lost across a resistor is proportional to the resistance of the component. The total potential difference is shared evenly across the total resistance of the circuit. This means that the potential difference per unit of resistance is

$$V_{\text{per unit of resistance}} = \frac{V_{\text{total}}}{R_{\text{total}}}$$

Then the voltage across a resistor is just the resistance times the potential difference per unit of resistance

$$V_{\text{resistor}} = R_{\text{resistor}} \cdot \frac{V_{\text{total}}}{R_{\text{total}}}$$

10.2.5 EMF

When you measure the potential difference across (or between) the terminals of a battery you are measuring the "electromotive force" (emf) of the battery. This is how much potential energy the battery has to make charges move through the circuit. This driving potential energy is equal to the total potential energy drops in the circuit. This means that the voltage across the battery is equal to the sum of the voltages in the circuit.

We can use this information to solve problems in which the voltages across elements in a circuit add up to the emf.

$$EMF = V_{\text{total}}$$



Worked Example 45: Voltages I

Question: What is the voltage across the resistor in the circuit shown?

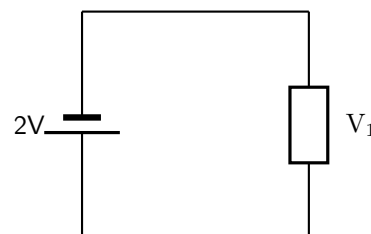

Answer

Step 1 : Check what you have and the units

We have a circuit with a battery and one resistor. We know the voltage across the battery. We want to find that voltage across the resistor.

$$V_{\text{battery}} = 2V$$

Step 2 : Applicable principles

We know that the voltage across the battery must be equal to the total voltage across all other circuit components.

$$V_{\text{battery}} = V_{\text{total}}$$

There is only one other circuit component, the resistor.

$$V_{total} = V_1$$

This means that the voltage across the battery is the same as the voltage across the resistor.

$$V_{battery} = V_{total} = V_1$$

$$V_{battery} = V_{total} = V_1$$

$$V_1 = 2V$$



Worked Example 46: Voltages II

Question: What is the voltage across the unknown resistor in the circuit shown?

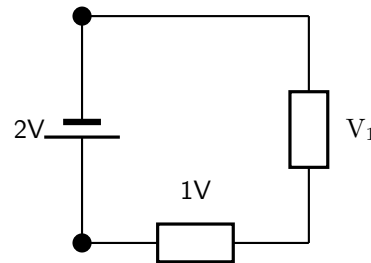

Answer

Step 1 : Check what you have and the units

We have a circuit with a battery and two resistors. We know the voltage across the battery and one of the resistors. We want to find that voltage across the resistor.

$$V_{battery} = 2V$$

$$V_{resistor} = 1V$$

Step 2 : Applicable principles

We know that the voltage across the battery must be equal to the total voltage across all other circuit components.

$$V_{battery} = V_{total}$$

The total voltage in the circuit is the sum of the voltages across the individual resistors

$$V_{total} = V_1 + V_{resistor}$$

Using the relationship between the voltage across the battery and total voltage across the resistors

$$V_{battery} = V_{total}$$

$$V_{battery} = V_1 + V_{resistor}$$

$$2V = V_1 + 1V$$

$$V_1 = 1V$$



Worked Example 47: Voltages III

Question: What is the voltage across the unknown resistor in the circuit shown?

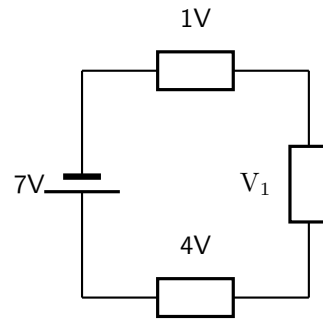

Answer

Step 1 : Check what you have and the units

We have a circuit with a battery and three resistors. We know the voltage across the battery and two of the resistors. We want to find that voltage across the unknown resistor.

$$V_{battery} = 7V$$

$$V_{known} = 1V + 4V$$

Step 2 : Applicable principles

We know that the voltage across the battery must be equal to the total voltage across all other circuit components.

$$V_{battery} = V_{total}$$

The total voltage in the circuit is the sum of the voltages across the individual resistors

$$V_{total} = V_1 + V_{known}$$

Using the relationship between the voltage across the battery and total voltage across the resistors

$$V_{battery} = V_{total}$$

$$V_{battery} = V_1 + V_{known}$$

$$7V = V_1 + 5V$$

$$V_1 = 2V$$



Worked Example 48: Voltages IV

Question: What is the voltage across the parallel resistor combination in the circuit shown? Hint: the rest of the circuit is the same as the previous problem.

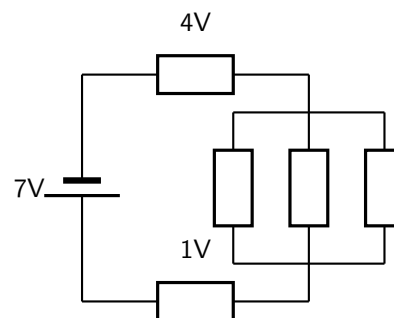

Answer

Step 1 : Quick Answer

The circuit is the same as the previous example and we know that the voltage difference between two points in a circuit does not depend on what is between them so the answer is the same as above $V_{parallel} = 2V$.

Step 2 : Check what you have and the units - long answer

We have a circuit with a battery and three resistors. We know the voltage across the battery and two of the resistors. We want to find that voltage across the parallel resistors, $V_{parallel}$.

$$V_{battery} = 7V$$

$$V_{known} = 1V + 4V$$

Step 3 : Applicable principles

We know that the voltage across the battery must be equal to the total voltage across all other circuit components.

$$V_{battery} = V_{total}$$

The total voltage in the circuit is the sum of the voltages across the individual resistors

$$V_{total} = V_{parallel} + V_{known}$$

Using the relationship between the voltage across the battery and total voltage across the resistors

$$V_{battery} = V_{total}$$

$$V_{battery} = V_{parallel} + V_{known}$$

$$7V = V_1 + 5V$$

$$V_{parallel} = 2V$$

10.3 Current

10.3.1 Flow of Charge

We have been talking about moving charge. We need to be able to deal with numbers, how much charge is moving, how fast is it moving? The concept that gives us this information is called *current*. Current allows us to quantify the movement of charge.

When we talk about current we talk about how much charge moves past a fixed point in circuit in one second. Think of charges being pushed around the circuit by the battery, there are charges in the wires but unless there is a battery they won't move. When one charge moves the charges next to it also move. They keep their spacing. If you had a tube of marbles like in this picture.



If you push one marble into the tube one must come out the other side. If you look at any point in the tube and push one marble into the tube, one marble will move past the point you are looking at. This is similar to charges in the wires of a circuit.

If a charge moves they all move and the same number move at every point in the circuit.

10.3.2 Current

Now that we've thought about the moving charges and visualised what is happening we need to get back to quantifying moving charge. I've already told you that we use current but we still need to define it.

Definition: Current

Current is the rate at which charges moves past a fixed point in a circuit. We use the symbol I to show current and it is measured in amperes (A). One ampere is one coulomb of charge moving in one second.

$$I = \frac{Q}{\Delta t}$$

When current flows in a circuit we show this on a diagram by adding arrows. The arrows show the direction of flow in a circuit. By convention we say that charge flows from the positive terminal on a battery to the negative terminal.

10.3.3 Series Circuits

In a series circuit, the charge has a single path from the battery, returning to the battery.

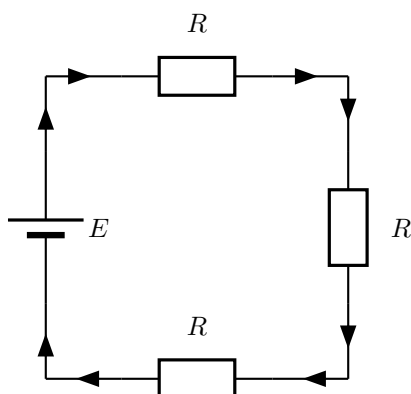

The arrows in this picture show you the direction that charge will flow in the circuit. They don't show you much charge will flow, only the direction.

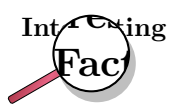

Benjamin Franklin made a guess about the direction of charge flow when rubbing smooth wax with rough wool. He thought that the charges flowed from the wax to the wool (i.e. from positive to negative) which was opposite to the real direction. Due to this, electrons are said to have a *negative* charge and so objects which Ben Franklin called “negative” (meaning a shortage of charge) really have an excess of electrons. By the time the true direction of electron flow was discovered, the convention of “positive” and “negative” had already been so well accepted in the scientific world that no effort was made to change it.



Important: A cell **does not** produce the same amount of current no matter what is connected to it. While the voltage produced by a cell is constant, the amount of current supplied depends on what is in the circuit.

How does the current through the battery in a circuit with several resistors in series compare to the current in a circuit with a single resistor?

Activity :: Experiment : Current in Series Circuits

Aim:

To determine the effect of multiple resistors on current in a circuit

Apparatus:

- Battery
- Resistors
- Light bulb
- Wires

Method:

1. Construct the following circuits

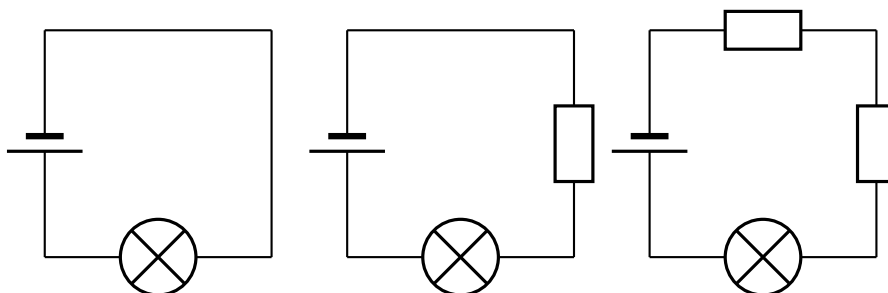

2. Rank the three circuits in terms of the brightness of the bulb.

Conclusions:

The brightness of the bulb is an indicator of how much current is flowing. If the bulb gets brighter because of a change then more current is flowing. If the bulb gets dimmer less current is flowing. You will find that the more resistors you have the dimmer the bulb.

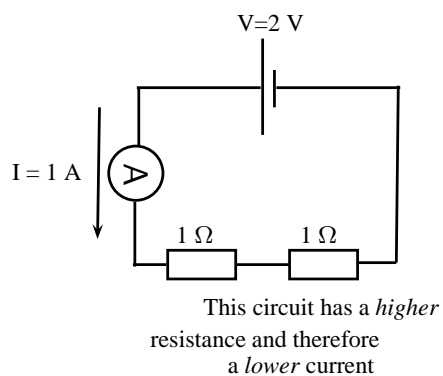
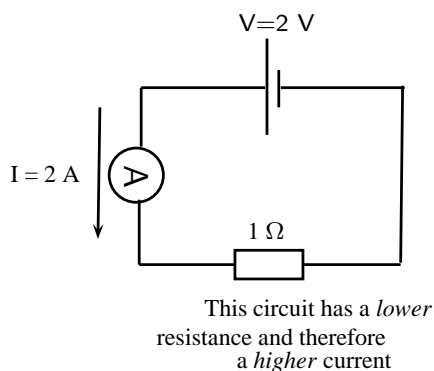
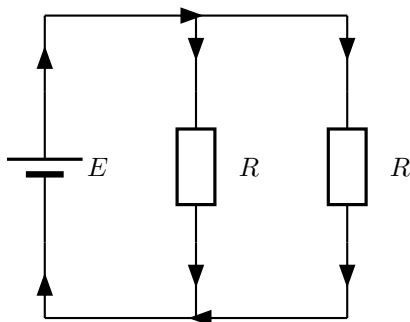
**10.3.4 Parallel Circuits**

How does the current through the battery in a circuit with several resistors in parallel compare to the current in a circuit with a single resistor?

Activity :: Experiment : Current in Series Circuits**Aim:**

To determine the effect of multiple resistors on current in a circuit

Apparatus:

- Battery
- Resistors
- Light bulb
- Wires

Method:

1. Construct the following circuits

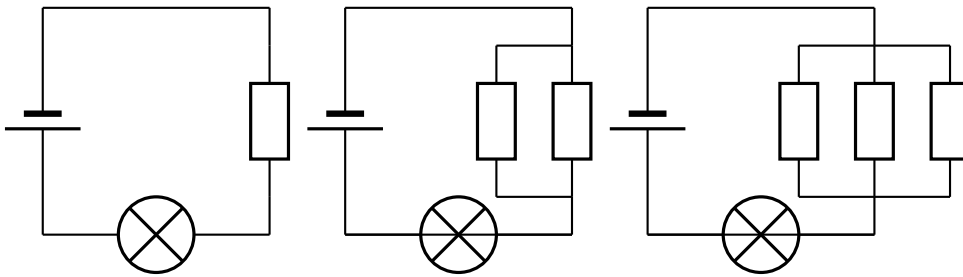

2. Rank the three circuits in terms of the brightness of the bulb.

Conclusions:

The brightness of the bulb is an indicator of how much current is flowing. If the bulb gets brighter because of a change then more current is flowing. If the bulb gets dimmer less current is flowing. You will find that the more resistors you have the brighter the bulb.

Why is this the case? Why do more resistors make it easier for charge to flow in the circuit? It is because they are in parallel so there are more paths for charge to take to move. You can think of it like a highway with more lanes, or the tube of marbles splitting into multiple parallel tubes. The more branches there are, the easier it is for charge to flow. You will learn more about the total resistance of parallel resistors later but always remember that more resistors in parallel mean more pathways. In series the pathways come one after the other so it does not make it easier for charge to flow.

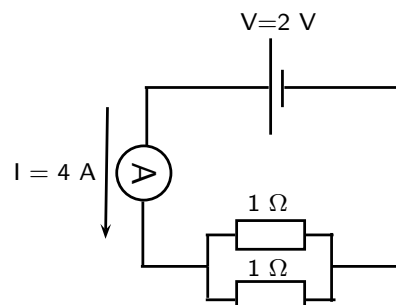
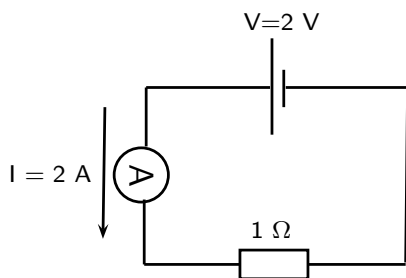

the 2 resistors in parallel result in a lower total resistance and therefore a higher current in the circuit

10.4 Resistance

10.4.1 What causes resistance?

We have spoken about resistors that slow down the flow of charge in a conductor. On a microscopic level, electrons moving through the conductor collide with the particles of which the conductor (metal) is made. When they collide, they transfer kinetic energy. The electrons therefore lose kinetic energy and slow down. This leads to resistance. The transferred energy causes the conductor to heat up. You can feel this directly if you touch a cellphone charger when you are charging a cell phone - the charger gets warm!



Definition: Resistance

Resistance slows down the flow of charge in a circuit. We use the symbol **R** to show resistance and it is measured in units called **Ohms** with the symbol Ω .

$$1 \text{ Ohm} = 1 \frac{\text{Volt}}{\text{Ampere}}.$$

All conductors have some resistance. For example, a piece of wire has less resistance than a light bulb, but both have resistance. The high resistance of the filament (small wire) in a lightbulb causes the electrons to transfer a lot of their kinetic energy in the form of heat. The heat energy is enough to cause the filament to glow white-hot which produces light. The wires connecting the lamp to the cell or battery hardly even get warm while conducting the same amount of current. This is because of their much lower resistance due to their larger cross-section (they are thicker).

An important effect of a resistor is that it *converts* electrical energy into other forms of energy, such as **heat** and **light**.

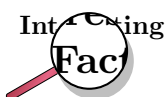

There is a special type of conductor, called a **superconductor** that has no resistance, but the materials that make up superconductors only start superconducting at very low temperatures (approximately -170°C).

Why do batteries go flat?

A battery stores chemical potential energy. When it is connected in a circuit, a chemical reaction takes place inside the battery which converts chemical potential energy to electrical energy which powers the electrons to move through the circuit. All the circuit elements (such as the conducting leads, resistors and lightbulbs) have some resistance to the flow of charge and convert the electrical energy to heat and/or light. The battery goes flat when all its chemical potential energy has been converted into other forms of energy.

10.4.2 Resistors in electric circuits

It is important to understand what effect adding resistors to a circuit has on the *total* resistance of a circuit and on the current that can flow in the circuit.

Resistors in series

When we add resistors in series to a circuit, we *increase* the resistance to the flow of current. There is only **one path** that the current can flow down and the current is the same at all places in the series circuit. Take a look at the diagram below: On the left there is a circuit with a single resistor and a battery. No matter where we measure the current, it is the same in a series circuit. On the right, we have added a second resistor in series to the circuit. The *total* resistance of the circuit has *increased* and you can see from the reading on the ammeter that the current in the circuit has decreased.

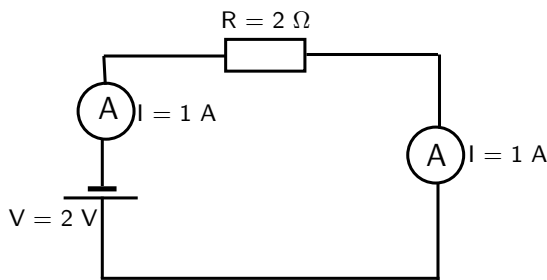

The current in a series circuit is the same everywhere

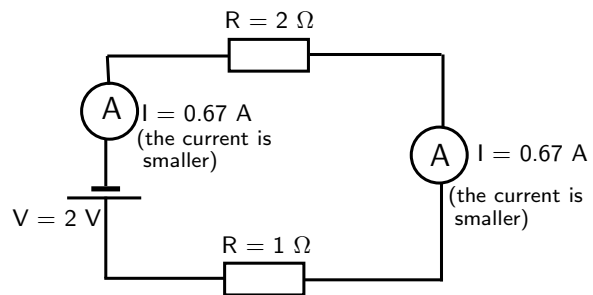

Adding a resistor to the circuit increases the total resistance

Resistors in parallel

In contrast to the series case, when we add resistors in parallel, we create **more paths** along which current can flow. By doing this we *decrease* the total resistance of the circuit!

Take a look at the diagram below. On the left we have the same circuit as in the previous diagram with a battery and a resistor. The ammeter shows a current of 1 ampere. On the right we have added a second resistor in parallel to the first resistor. This has increased the number of paths (branches) the charge can take through the circuit - the total resistance has decreased. You can see that the current in the circuit has increased. Also notice that the current in the different branches can be different.

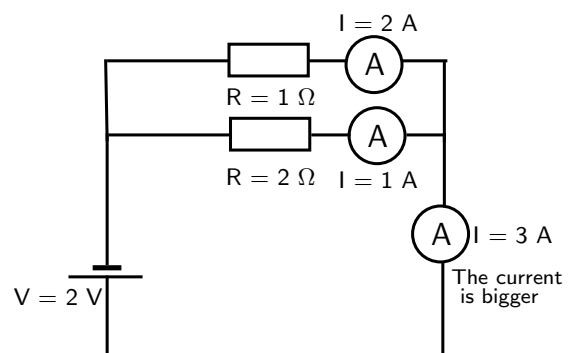
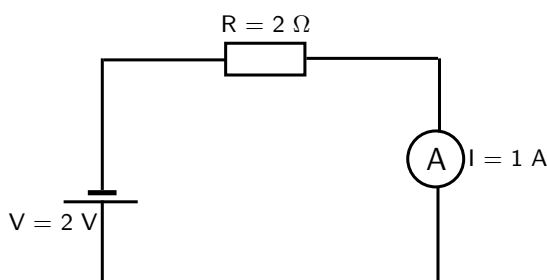

Adding a resistor to the circuit in parallel decreases the total resistance



Exercise: Resistance

1. What is the unit of resistance called and what is its symbol?
2. Explain what happens to the total resistance of a circuit when resistors are added in series?

3. Explain what happens to the total resistance of a circuit when resistors are added in parallel?
4. Why do batteries go flat?

10.5 Instruments to Measure voltage, current and resistance

As we have seen in previous sections, an electric circuit is made up of a number of different components such as batteries, resistors and light bulbs. There are devices to measure the properties of these components. These devices are called meters.

For example, one may be interested in measuring the amount of current flowing through a circuit using an *ammeter* or measuring the voltage provided by a battery using a *voltmeter*. In this section we will discuss the practical usage of voltmeters, ammeters, and *ohmmeters*.

10.5.1 Voltmeter

A voltmeter is an instrument for measuring the voltage between two points in an electric circuit. In analogy with a water circuit, a voltmeter is like a meter designed to measure pressure difference. Since one is interested in measuring the voltage between two points in a circuit, a voltmeter must be connected in *parallel* with the portion of the circuit on which the measurement is made.

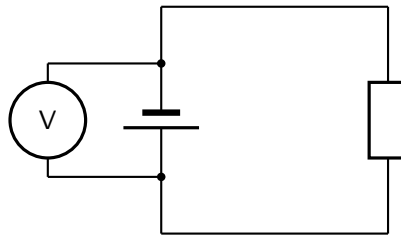

Figure 10.3: A voltmeter should be connected in parallel in a circuit.

Figure 10.3 shows a voltmeter connected in parallel with a battery. One lead of the voltmeter is connected to one end of the battery and the other lead is connected to the opposite end. The voltmeter may also be used to measure the voltage across a resistor or any other component of a circuit that has a voltage drop.

10.5.2 Ammeter

An ammeter is an instrument used to measure the flow of electric current in a circuit. Since one is interested in measuring the current flowing *through* a circuit component, the ammeter must be connected in *series* with the measured circuit component (Figure 10.4).

10.5.3 Ohmmeter

An ohmmeter is an instrument for measuring electrical resistance. The basic ohmmeter can function much like an ammeter. The ohmmeter works by supplying a constant voltage to the resistor and measuring the current flowing through it. The measured current is then converted into a corresponding resistance reading through Ohm's Law. Ohmmeters only function correctly when measuring resistance that is not being powered by a voltage or current source. In other words, you cannot measure the resistance of a component that is already connected to a circuit. This is because the ohmmeter's accurate indication depends only on its own source of voltage.

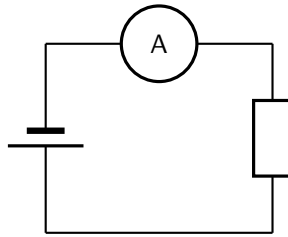

Figure 10.4: An ammeter should be connected in series in a circuit.

The presence of **any other** voltage across the measured circuit component interferes with the ohmmeter's operation. Figure 10.5 shows an ohmmeter connected with a resistor.

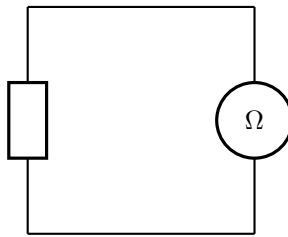

Figure 10.5: An ohmmeter should be used outside when there are no voltages present in the circuit.

10.5.4 Meters Impact on Circuit

A good quality meter used correctly will not significantly change the values it is used to measure. This means that an ammeter has very low resistance to not slow down the flow of charge.

A voltmeter has a very high resistance so that it does not add another parallel pathway to the circuit for the charge to flow along.

Activity :: Investigation : Using meters

If possible, connect meters in circuits to get used to the use of meters to measure electrical quantities. If the meters have more than one scale, always connect to the **largest scale** first so that the meter will not be damaged by having to measure values that exceed its limits.

The table below summarises the use of each measuring instrument that we discussed and the way it should be connected to a circuit component.

Instrument	Measured Quantity	Proper Connection
Voltmeter	Voltage	In Parallel
Ammeter	Current	In Series
Ohmmeter	Resistance	Only with Resistor

10.6 Exercises - Electric circuits

1. Write definitions for each of the following:

- 1.1 resistor
- 1.2 coulomb
- 1.3 voltmeter
2. Draw a circuit diagram which consists of the following components:
 - 2.1 2 batteries in parallel
 - 2.2 an open switch
 - 2.3 2 resistors in parallel
 - 2.4 an ammeter measuring total current
 - 2.5 a voltmeter measuring potential difference across one of the parallel resistors
3. Complete the table below:

Quantity	Symbol	Unit of measurement	Symbol of unit
e.g. Distance	e.g. d	e.g. kilometer	e.g. km
Resistance			
Current			
Potential difference			

4. [SC 2003/11] The emf of a battery can best be explained as the ...
 - 4.1 rate of energy delivered per unit current
 - 4.2 rate at which charge is delivered
 - 4.3 rate at which energy is delivered
 - 4.4 charge per unit of energy delivered by the battery
5. [IEB 2002/11 HG1] Which of the following is the correct definition of the emf of a cell?
 - 5.1 It is the product of current and the external resistance of the circuit.
 - 5.2 It is a measure of the cell's ability to conduct an electric current.
 - 5.3 It is equal to the "lost volts" in the internal resistance of the circuit.
 - 5.4 It is the power dissipated per unit current passing through the cell.
6. [IEB 2005/11 HG] Three identical light bulbs A, B and C are connected in an electric circuit as shown in the diagram below.

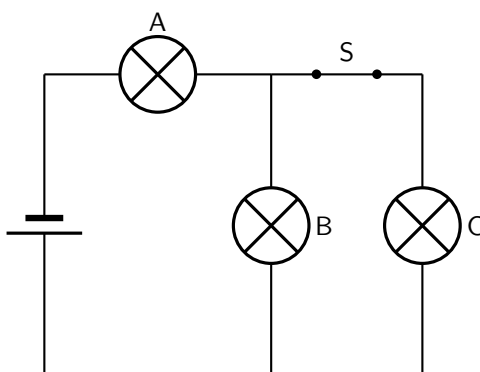

How do the currents in bulbs A and B change when switch S is opened?

	Current in A	Current in B
(a)	decreases	increases
(b)	decreases	decreases
(c)	increases	increases
(d)	increases	decreases

7. [IEB 2004/11 HG1] When a current I is maintained in a conductor for a time of t , how many electrons with charge e pass any cross-section of the conductor per second?

7.1 It

7.2 It/e

7.3 Ite

7.4 e/It

Appendix A

GNU Free Documentation License

Version 1.2, November 2002

Copyright © 2000,2001,2002 Free Software Foundation, Inc.

59 Temple Place, Suite 330, Boston, MA 02111-1307 USA

Everyone is permitted to copy and distribute verbatim copies of this license document, but changing it is not allowed.

PREAMBLE

The purpose of this License is to make a manual, textbook, or other functional and useful document “free” in the sense of freedom: to assure everyone the effective freedom to copy and redistribute it, with or without modifying it, either commercially or non-commercially. Secondly, this License preserves for the author and publisher a way to get credit for their work, while not being considered responsible for modifications made by others.

This License is a kind of “copyleft”, which means that derivative works of the document must themselves be free in the same sense. It complements the GNU General Public License, which is a copyleft license designed for free software.

We have designed this License in order to use it for manuals for free software, because free software needs free documentation: a free program should come with manuals providing the same freedoms that the software does. But this License is not limited to software manuals; it can be used for any textual work, regardless of subject matter or whether it is published as a printed book. We recommend this License principally for works whose purpose is instruction or reference.

APPLICABILITY AND DEFINITIONS

This License applies to any manual or other work, in any medium, that contains a notice placed by the copyright holder saying it can be distributed under the terms of this License. Such a notice grants a world-wide, royalty-free license, unlimited in duration, to use that work under the conditions stated herein. The “Document”, below, refers to any such manual or work. Any member of the public is a licensee, and is addressed as “you”. You accept the license if you copy, modify or distribute the work in a way requiring permission under copyright law.

A “Modified Version” of the Document means any work containing the Document or a portion of it, either copied verbatim, or with modifications and/or translated into another language.

A “Secondary Section” is a named appendix or a front-matter section of the Document that deals exclusively with the relationship of the publishers or authors of the Document to the Document’s overall subject (or to related matters) and contains nothing that could fall directly within that overall subject. (Thus, if the Document is in part a textbook of mathematics, a

Secondary Section may not explain any mathematics.) The relationship could be a matter of historical connection with the subject or with related matters, or of legal, commercial, philosophical, ethical or political position regarding them.

The “Invariant Sections” are certain Secondary Sections whose titles are designated, as being those of Invariant Sections, in the notice that says that the Document is released under this License. If a section does not fit the above definition of Secondary then it is not allowed to be designated as Invariant. The Document may contain zero Invariant Sections. If the Document does not identify any Invariant Sections then there are none.

The “Cover Texts” are certain short passages of text that are listed, as Front-Cover Texts or Back-Cover Texts, in the notice that says that the Document is released under this License. A Front-Cover Text may be at most 5 words, and a Back-Cover Text may be at most 25 words.

A “Transparent” copy of the Document means a machine-readable copy, represented in a format whose specification is available to the general public, that is suitable for revising the document straightforwardly with generic text editors or (for images composed of pixels) generic paint programs or (for drawings) some widely available drawing editor, and that is suitable for input to text formatters or for automatic translation to a variety of formats suitable for input to text formatters. A copy made in an otherwise Transparent file format whose markup, or absence of markup, has been arranged to thwart or discourage subsequent modification by readers is not Transparent. An image format is not Transparent if used for any substantial amount of text. A copy that is not “Transparent” is called “Opaque”.

Examples of suitable formats for Transparent copies include plain ASCII without markup, Texinfo input format, \LaTeX input format, SGML or XML using a publicly available DTD and standard-conforming simple HTML, PostScript or PDF designed for human modification. Examples of transparent image formats include PNG, XCF and JPG. Opaque formats include proprietary formats that can be read and edited only by proprietary word processors, SGML or XML for which the DTD and/or processing tools are not generally available, and the machine-generated HTML, PostScript or PDF produced by some word processors for output purposes only.

The “Title Page” means, for a printed book, the title page itself, plus such following pages as are needed to hold, legibly, the material this License requires to appear in the title page. For works in formats which do not have any title page as such, “Title Page” means the text near the most prominent appearance of the work’s title, preceding the beginning of the body of the text.

A section “Entitled XYZ” means a named subunit of the Document whose title either is precisely XYZ or contains XYZ in parentheses following text that translates XYZ in another language. (Here XYZ stands for a specific section name mentioned below, such as “Acknowledgements”, “Dedications”, “Endorsements”, or “History”.) To “Preserve the Title” of such a section when you modify the Document means that it remains a section “Entitled XYZ” according to this definition.

The Document may include Warranty Disclaimers next to the notice which states that this License applies to the Document. These Warranty Disclaimers are considered to be included by reference in this License, but only as regards disclaiming warranties: any other implication that these Warranty Disclaimers may have is void and has no effect on the meaning of this License.

VERBATIM COPYING

You may copy and distribute the Document in any medium, either commercially or non-commercially, provided that this License, the copyright notices, and the license notice saying this License applies to the Document are reproduced in all copies, and that you add no other conditions whatsoever to those of this License. You may not use technical measures to obstruct or control the reading or further copying of the copies you make or distribute. However, you may accept compensation in exchange for copies. If you distribute a large enough number of copies you must also follow the conditions in section A.

You may also lend copies, under the same conditions stated above, and you may publicly display copies.

COPYING IN QUANTITY

If you publish printed copies (or copies in media that commonly have printed covers) of the Document, numbering more than 100, and the Document's license notice requires Cover Texts, you must enclose the copies in covers that carry, clearly and legibly, all these Cover Texts: Front-Cover Texts on the front cover, and Back-Cover Texts on the back cover. Both covers must also clearly and legibly identify you as the publisher of these copies. The front cover must present the full title with all words of the title equally prominent and visible. You may add other material on the covers in addition. Copying with changes limited to the covers, as long as they preserve the title of the Document and satisfy these conditions, can be treated as verbatim copying in other respects.

If the required texts for either cover are too voluminous to fit legibly, you should put the first ones listed (as many as fit reasonably) on the actual cover, and continue the rest onto adjacent pages.

If you publish or distribute Opaque copies of the Document numbering more than 100, you must either include a machine-readable Transparent copy along with each Opaque copy, or state in or with each Opaque copy a computer-network location from which the general network-using public has access to download using public-standard network protocols a complete Transparent copy of the Document, free of added material. If you use the latter option, you must take reasonably prudent steps, when you begin distribution of Opaque copies in quantity, to ensure that this Transparent copy will remain thus accessible at the stated location until at least one year after the last time you distribute an Opaque copy (directly or through your agents or retailers) of that edition to the public.

It is requested, but not required, that you contact the authors of the Document well before redistributing any large number of copies, to give them a chance to provide you with an updated version of the Document.

MODIFICATIONS

You may copy and distribute a Modified Version of the Document under the conditions of sections A and A above, provided that you release the Modified Version under precisely this License, with the Modified Version filling the role of the Document, thus licensing distribution and modification of the Modified Version to whoever possesses a copy of it. In addition, you must do these things in the Modified Version:

1. Use in the Title Page (and on the covers, if any) a title distinct from that of the Document, and from those of previous versions (which should, if there were any, be listed in the History section of the Document). You may use the same title as a previous version if the original publisher of that version gives permission.
2. List on the Title Page, as authors, one or more persons or entities responsible for authorship of the modifications in the Modified Version, together with at least five of the principal authors of the Document (all of its principal authors, if it has fewer than five), unless they release you from this requirement.
3. State on the Title page the name of the publisher of the Modified Version, as the publisher.
4. Preserve all the copyright notices of the Document.
5. Add an appropriate copyright notice for your modifications adjacent to the other copyright notices.

6. Include, immediately after the copyright notices, a license notice giving the public permission to use the Modified Version under the terms of this License, in the form shown in the Addendum below.
7. Preserve in that license notice the full lists of Invariant Sections and required Cover Texts given in the Document's license notice.
8. Include an unaltered copy of this License.
9. Preserve the section Entitled "History", Preserve its Title, and add to it an item stating at least the title, year, new authors, and publisher of the Modified Version as given on the Title Page. If there is no section Entitled "History" in the Document, create one stating the title, year, authors, and publisher of the Document as given on its Title Page, then add an item describing the Modified Version as stated in the previous sentence.
10. Preserve the network location, if any, given in the Document for public access to a Transparent copy of the Document, and likewise the network locations given in the Document for previous versions it was based on. These may be placed in the "History" section. You may omit a network location for a work that was published at least four years before the Document itself, or if the original publisher of the version it refers to gives permission.
11. For any section Entitled "Acknowledgements" or "Dedications", Preserve the Title of the section, and preserve in the section all the substance and tone of each of the contributor acknowledgements and/or dedications given therein.
12. Preserve all the Invariant Sections of the Document, unaltered in their text and in their titles. Section numbers or the equivalent are not considered part of the section titles.
13. Delete any section Entitled "Endorsements". Such a section may not be included in the Modified Version.
14. Do not re-title any existing section to be Entitled "Endorsements" or to conflict in title with any Invariant Section.
15. Preserve any Warranty Disclaimers.

If the Modified Version includes new front-matter sections or appendices that qualify as Secondary Sections and contain no material copied from the Document, you may at your option designate some or all of these sections as invariant. To do this, add their titles to the list of Invariant Sections in the Modified Version's license notice. These titles must be distinct from any other section titles.

You may add a section Entitled "Endorsements", provided it contains nothing but endorsements of your Modified Version by various parties—for example, statements of peer review or that the text has been approved by an organisation as the authoritative definition of a standard.

You may add a passage of up to five words as a Front-Cover Text, and a passage of up to 25 words as a Back-Cover Text, to the end of the list of Cover Texts in the Modified Version. Only one passage of Front-Cover Text and one of Back-Cover Text may be added by (or through arrangements made by) any one entity. If the Document already includes a cover text for the same cover, previously added by you or by arrangement made by the same entity you are acting on behalf of, you may not add another; but you may replace the old one, on explicit permission from the previous publisher that added the old one.

The author(s) and publisher(s) of the Document do not by this License give permission to use their names for publicity for or to assert or imply endorsement of any Modified Version.

COMBINING DOCUMENTS

You may combine the Document with other documents released under this License, under the terms defined in section A above for modified versions, provided that you include in the

combination all of the Invariant Sections of all of the original documents, unmodified, and list them all as Invariant Sections of your combined work in its license notice, and that you preserve all their Warranty Disclaimers.

The combined work need only contain one copy of this License, and multiple identical Invariant Sections may be replaced with a single copy. If there are multiple Invariant Sections with the same name but different contents, make the title of each such section unique by adding at the end of it, in parentheses, the name of the original author or publisher of that section if known, or else a unique number. Make the same adjustment to the section titles in the list of Invariant Sections in the license notice of the combined work.

In the combination, you must combine any sections Entitled “History” in the various original documents, forming one section Entitled “History”; likewise combine any sections Entitled “Acknowledgements”, and any sections Entitled “Dedications”. You must delete all sections Entitled “Endorsements”.

COLLECTIONS OF DOCUMENTS

You may make a collection consisting of the Document and other documents released under this License, and replace the individual copies of this License in the various documents with a single copy that is included in the collection, provided that you follow the rules of this License for verbatim copying of each of the documents in all other respects.

You may extract a single document from such a collection, and distribute it individually under this License, provided you insert a copy of this License into the extracted document, and follow this License in all other respects regarding verbatim copying of that document.

AGGREGATION WITH INDEPENDENT WORKS

A compilation of the Document or its derivatives with other separate and independent documents or works, in or on a volume of a storage or distribution medium, is called an “aggregate” if the copyright resulting from the compilation is not used to limit the legal rights of the compilation’s users beyond what the individual works permit. When the Document is included an aggregate, this License does not apply to the other works in the aggregate which are not themselves derivative works of the Document.

If the Cover Text requirement of section A is applicable to these copies of the Document, then if the Document is less than one half of the entire aggregate, the Document’s Cover Texts may be placed on covers that bracket the Document within the aggregate, or the electronic equivalent of covers if the Document is in electronic form. Otherwise they must appear on printed covers that bracket the whole aggregate.

TRANSLATION

Translation is considered a kind of modification, so you may distribute translations of the Document under the terms of section A. Replacing Invariant Sections with translations requires special permission from their copyright holders, but you may include translations of some or all Invariant Sections in addition to the original versions of these Invariant Sections. You may include a translation of this License, and all the license notices in the Document, and any Warranty Disclaimers, provided that you also include the original English version of this License and the original versions of those notices and disclaimers. In case of a disagreement between the translation and the original version of this License or a notice or disclaimer, the original version will prevail.

If a section in the Document is Entitled “Acknowledgements”, “Dedications”, or “History”, the requirement (section A) to Preserve its Title (section A) will typically require changing the

actual title.

TERMINATION

You may not copy, modify, sub-license, or distribute the Document except as expressly provided for under this License. Any other attempt to copy, modify, sub-license or distribute the Document is void, and will automatically terminate your rights under this License. However, parties who have received copies, or rights, from you under this License will not have their licenses terminated so long as such parties remain in full compliance.

FUTURE REVISIONS OF THIS LICENSE

The Free Software Foundation may publish new, revised versions of the GNU Free Documentation License from time to time. Such new versions will be similar in spirit to the present version, but may differ in detail to address new problems or concerns. See <http://www.gnu.org/copyleft/>.

Each version of the License is given a distinguishing version number. If the Document specifies that a particular numbered version of this License “or any later version” applies to it, you have the option of following the terms and conditions either of that specified version or of any later version that has been published (not as a draft) by the Free Software Foundation. If the Document does not specify a version number of this License, you may choose any version ever published (not as a draft) by the Free Software Foundation.

ADDENDUM: How to use this License for your documents

To use this License in a document you have written, include a copy of the License in the document and put the following copyright and license notices just after the title page:

Copyright © YEAR YOUR NAME. Permission is granted to copy, distribute and/or modify this document under the terms of the GNU Free Documentation License, Version 1.2 or any later version published by the Free Software Foundation; with no Invariant Sections, no Front-Cover Texts, and no Back-Cover Texts. A copy of the license is included in the section entitled “GNU Free Documentation License”.

If you have Invariant Sections, Front-Cover Texts and Back-Cover Texts, replace the “with...Texts.” line with this:

with the Invariant Sections being LIST THEIR TITLES, with the Front-Cover Texts being LIST, and with the Back-Cover Texts being LIST.

If you have Invariant Sections without Cover Texts, or some other combination of the three, merge those two alternatives to suit the situation.

If your document contains nontrivial examples of program code, we recommend releasing these examples in parallel under your choice of free software license, such as the GNU General Public License, to permit their use in free software.